

Manufactured Housing Anchor Installation Information

(Updated: January 2009)

Provided by

TIE DOWN ENGINEERING



Pages 1 through 10 plus
Soil Chart and Anchor Chart

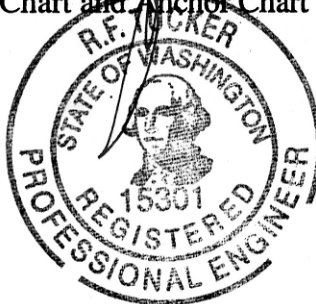

**TIE DOWN ENGINEERING • 255 Villanova Drive SW • Atlanta, GA 30336
www.tiedown.com (404) 344-0000 Fax (404) 349-0401**

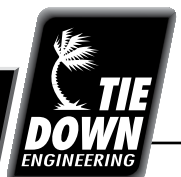

010809.d12

INSTALLATION INFORMATION

Anchor Installation

1. Position anchor at a slight back angle (10°) so that when fully installed, the anchor head will be inside any skirting or side wall.
2. Install anchor to +/- 2/3 depth, then install stabilizer vertically, within 3"-4" of anchor shaft, parallel to wall of home.
3. Fully drive anchor, attach strap (see proper strap tensioning), and pretension strap to pull anchor rod against the stabilizer plate.

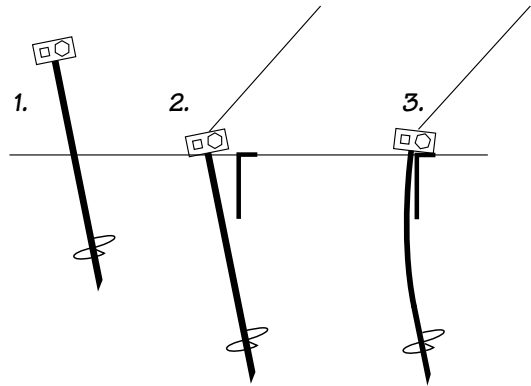

Manual Anchor Installation

1. Dig holes to a depth of 2/3 of the anchor length. Install anchor with rod or length of pipe for leverage.
2. Replace earth in hole after anchor/plate is installed at full depth. Pack dirt with a tamping rod every 6 inches of fill.
3. Testing may be required in loose soil conditions to check that anchor has proper holding power.

Important:
Anchor must be installed to full depth. Anchor head must be at ground level or at the top of the stabilizer plate which is fully installed to ground level.

Electric Drive Machine Installation

Operating Instructions:

1. Attach adapter head to shaft of the EDM motor, tighten set screw.
2. Place extension handle in the end of the EDM if needed.
3. Place anchor head into adapter, line up anchor shaft with EDM shaft, for easier installation.
4. Flip forward/reverse switch to forward.
5. Place anchor tip in location where anchor is to be buried. Hold on/off switch to install.



Adapter fits anchors and Soil Test Probe



EDM Adapter Head.



Two man operation makes easy work of anchor installation

Electric Drive Machine Cautions and Warnings:

- Before installation of any ground anchor, determine that the ground anchors to be installed will not be near any underground electrical cables, phone lines, water lines, sewer pipes, or gas lines. Failure to do so may result in serious injury or death
- The EDM is designed for operation by two people.
- Do not allow the EDM to be wedged against the home or other solid objects, when operating the EDM.
- Electrical cord must be a minimum of 14-2 wire size w/ground up to 25 ft. of cord. Longer cords must be 12-2 wire size w/ground or lower.
- Never operate the EDM in wet or rainy conditions.
- Frayed or patched electrical cords should never be used with the EDM.
- Care should be taken to keep electrical cords away from anchors.
- Never operate drive machine without the GFI power cord. Damage to motor and injury to operator can result from by passing the GFI.
- The GFI will shut off power when a ground fault is detected. The GFI will also shut off power when it detects low voltage improper amps required to drive the motor. Many times the problem will be the use of an extension cord that is too long or is too light in gage.

INSTALLATION INFORMATION

Stabilization Plates

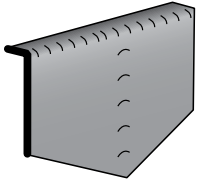

Class 4B Stabilizer Plate
17-1/2" x 13-1/2"
Galvanized: Part # 59286

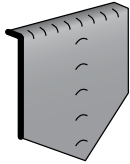

12" wide Stabilizer Plate
Black Paint: Part #59292
Galvanized: Part #59292G



ABS Stabilizer Plate
10" x 24"
Part # 59293

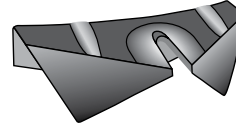

Quik-Set Stabilizer Plate
Black Paint: Part #59291
Galvanized: #59291G

Anchor Stabilizer

In order to prevent lateral movement of manufactured homes subjected to high wind loads and to comply with HUD's Wind Zone I, II, & III requirements, all lateral frame ties must be attached to a properly stabilized ground anchor. (Two approved methods illustrated below.)

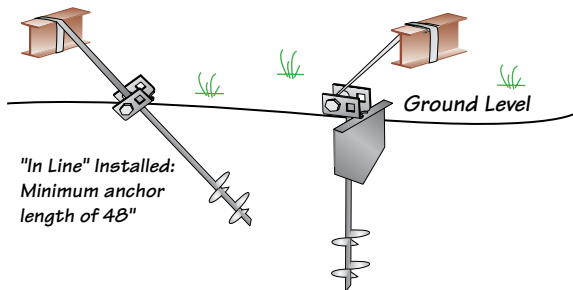

Stabilizer Plate Installation

1. Refer to any and all local, state and federal regulations.
2. Use the Soil Test Probe at the anchor location in order to match soil class with the anchor/stabilizer.. (See Page 11)
3. Partially install anchor to allow 14" to 16" remaining above ground level.
4. Utilizing oversized hammer, vertically install stabilizer plate, nesting anchor rod in between formed channels on outside of stabilizer plate (between anchor and frame).
5. Fully install anchor so that head is at the surface of the soil (1" tolerance, if necessary) and pretension anchor until touching stabilizer plate.

ABS Stabilizer Plate

Part # 59293

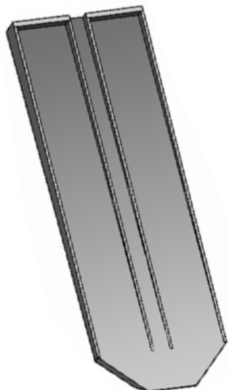

1. Determine correct anchor to be used with the home installation and use the manufacturer instruction for installation, following all safety precautions.
2. Using an electric drive machine, install anchor to a depth of approximately 28 inches at a slight back angle.
3. Dig out an 8" wide area so that the ABS stabilizer will be placed on undisturbed soil at a 10 to 15 degree angle toward the home. The bottom center of the plate should be touching the anchor rod.
4. Complete the installation of the ground anchor until the bottom of the anchor head is flush with the ground.
5. Attach proper strap and tension strap until anchor head is flush against the ABS plate and strap is tight. At this point, soil should be tamped into the vacant area behind the anchor rod, tamping approximately 6" and repeating until the vacant area is flush with the surface of the surrounding ground.

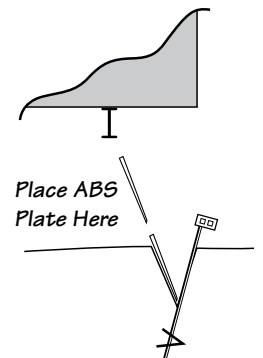

INSTALLATION INFORMATION

Quik-Set Stabilizer Installation

Black Paint Part: #59291
Galvanized Part: #59291G

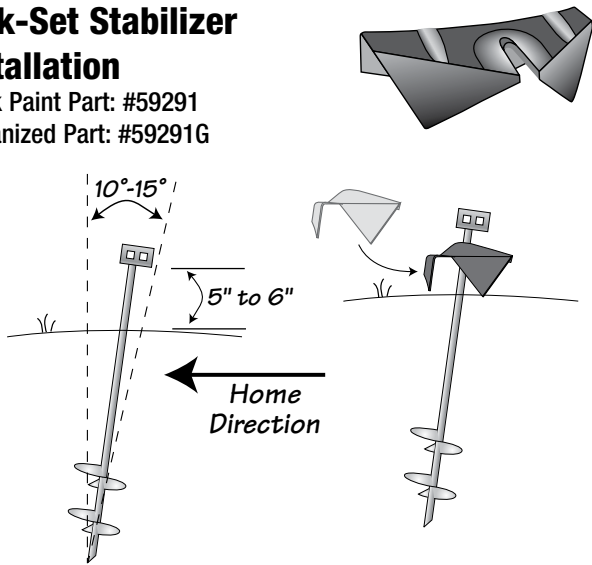

1. Install ground anchor inside skirting line at a slight back angle of 10° - 15°.
2. While anchor head is still 5" to 6" above ground level: install Quik Set stabilization plate around anchor shaft, referring to the direction imprinted on the top of the plate.
3. Install ground anchor until Quik-Set plate is fully set. Hammering may be required at the corners to insure plate being fully driven.
4. Install strap(s) to anchor head and pretension according to approved methods. Maximum anchor load in conjunction with the "Quik-Set" device is 4725 lbs. (ultimate).

Deep Set Anchor/Stabilizer Instructions

1. Confirm soil classification using standard torque probe at 36" below ground surface, make certain readings meet or exceed 350 in lbs. (Class 2 and 3 soils) at the depths of 12" & 36".
2. Clear loose vegetation where anchor will be installed. Install anchor vertically to its' full depth. Stabilizer plate at the top of anchor must be fully embedded into soil.
3. Pull strap past anchor head and cut strap so that there is 12" to 15" of strap to wrap onto anchor bolt insuring 4 to 5 wraps minimum.
4. Insert strap into anchor bolt flush with opposite side of bolt. Tighten bolt/strap until tight. Secure anchor bolt with nut.

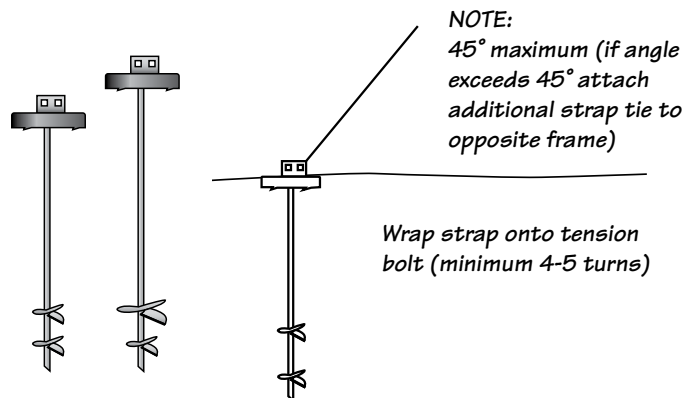

Certified Galvanized Strapping*

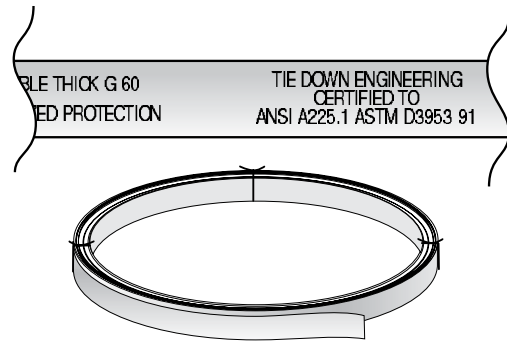

The steel strapping by Tie Down Engineering for the manufactured housing industry has been tested to, and conforms to, the HUD Code as referenced in Part 3280 of the Manufactured Home Construction and Safety Standards and Part 3285 of the installation standards; Final Rule.

3280.306(f), 3285.402(b2) Anchoring Equipment – Load Resistance. Anchoring equipment shall be capable of resisting an allowable working load equal to or exceeding 3,150 pounds and shall be capable of withstanding a 50 percent overload (4,725 pounds total) without failure of either the anchoring equipment or the attachment point on the manufactured home.

3280.306(g), 3285.402(b2) Anchoring Equipment – Weatherization. Anchoring equipment exposed to weathering shall have a resistance to weather deterioration at least equivalent to that provided by a coating of zinc on steel of not less than 0.30 ounces per square foot of surface coated, and in accordance with the following:

- (1) Slit or cut edges of zinc-coated steel strapping do not need to be zinc coated.
- (2) Type 1, Finish B, Grade 1 steel strapping, 1-1/4 inches wide and 0.035 inches in thickness, certified by a registered professional engineer or architect as conforming with ASTM Standard Specification D3953-91, Standard Specification for Strapping, Flat Steel, and Seals.

The above specification of a minimum coating of 0.30 ounces per square foot equates to a designation of "G30." Tie Down strapping exceeds this minimum requirement with a coating of 0.60 (G60) or 1.20 (G120) ounces as per above. Similarly, Tie Down strapping exceeds, in testing, the minimum load requirements of 3,150 pounds design (working) load and 4,725 pounds (ultimate) overload.

* Available with G60 or G20 galvanized coatings.

INSTALLATION INFORMATION

Proper Strap Tensioning

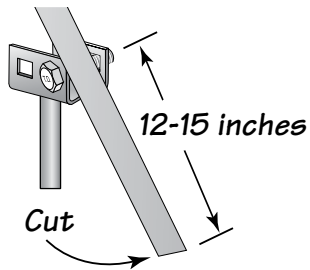

1. Insert slotted bolt into anchor head, attach loosely. Pull strap past bolt head and cut strap so that 12-15 inches of strap are available to wrap onto the slotted bolt.

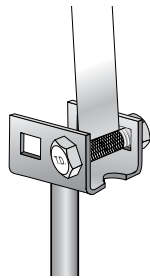

2. Insert the strap end into the slot in bolt until flush with opposite side of bolt.

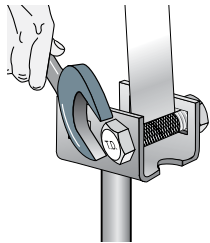

3. Using 15/16" wrench or socket, turn the bolt, winding the strap so that a minimum of four to five complete turns are made, and the strap is adequately tensioned.

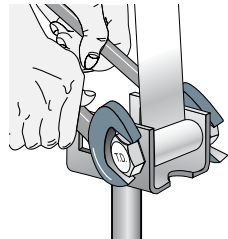

4. Hold the bolt under tension while tightening the nut, drawing the head of the bolt into the recess. After the bolt is within the recess, continue to tighten the nut until securely fastened.

Tip: TIE DOWN'S SPEED WRENCH cuts time required to tension strap in half!

Strap Tensioning - Speed Wrench

Tie Down's SPEED WRENCH simplifies anchor installation with a design that allows for one handed operation for installing slotted bolts and tensioning strap. The SPEED WRENCH has a 15/16" impact socket on one side and a 15/16" "nut" on the other. Combine this with your own ratchet and 15/16" socket and you have the fastest way to tighten slotted bolts!
Part # 48900

1. Place Speed Wrench over the bolt head. Insert the strap end into the slot in bolt until flush with opposite side of bolt.



2. Hold Speed Wrench in place, tighten bolt with socket wrench on outside of Speed Wrench (bolt head side).



3. Move socket to the opposite (nut) side. Hold Speed Wrench in place. Use socket wrench to tighten nut.



Strap Attachment

One crimp seal is used when strap is attached to a sidewall bracket or a strap connector. If the bracket does not have a radius edge, a radius clip (short "U" shaped piece of strap) must be placed between the strap and contact point to protect the strap from sharp edges. Verify state requirements for number of crimp seals required.

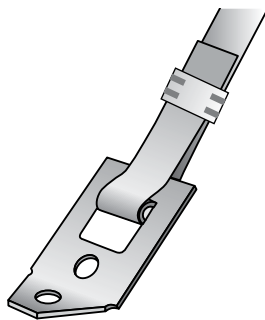

Strap Splice



2 Seals - 2 Crimps per seal

To lengthen strap in the field, a double crimp seal splice is required. Overlap strap approximately 12 inches and use two crimp seals evenly spaced, with 2 crimps per seal.

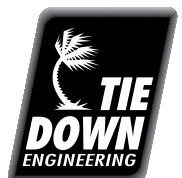

010809.d12

INSTALLATION INFORMATION

1. Refer to local, State, and Federal regulations prior to installation in order to assure compliance.
2. Soil Test Probe the anchor location prior to installation in order to match the soil classification with the proper anchor/stabilizer combination.
3. Install tested and approved Tie Down Engineering anchor products. 59002 & 59242 Swivel Strap Connectors.

Swivel Strap Connectors

Beam Method:

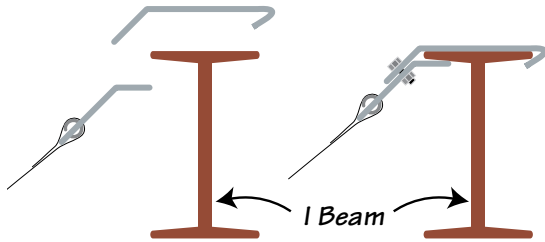

1. Frame ties attach to the beam with a swivel frame connector. This method provides the strongest and safest connection.
2. Attach the swivel frame connector beam hook to the top of the I-beam from either the front or the back side. The angled or hook end of the beam hook should be snug against the inside top I-beam flange.
3. Attach the swivel connector to the underside of the flange and frame hook with a 1/2" grade 5 bolt and nut. This allows the swivel connector to pivot and lock onto the I-beam.

Universal Swivel Strap Connector

Sidewall Methods:

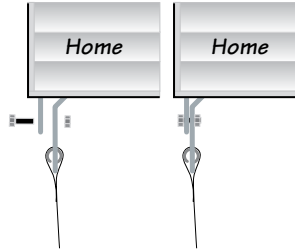

Sidewall w/Nut & Bolt
Attach strap connector to sidewall connector with nut & bolt, then attach to ground anchor.

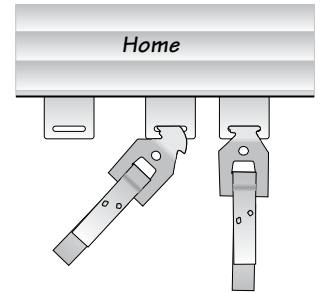

Sidewall & Longitudinal Slotted
Insert strap connector at a 45 degree angle. Return to 90 degree angle, pull down and attach to ground anchor. (Slotted connections must be straight pull. Bolted connections can have 15 degree max. angle.)

Gator Beam Clamp

4 Bolt Gator Clamp (Wind Zone 1,2 & 3)

#58999

8 Bolt Gator Clamp (Wind Zone 3 - and Florida)

#59011

NOTE: Gator Beam Clamps must be attached with a Swivel Strap Connector #59002. One crimp seal is used when strap is attached strap connector.

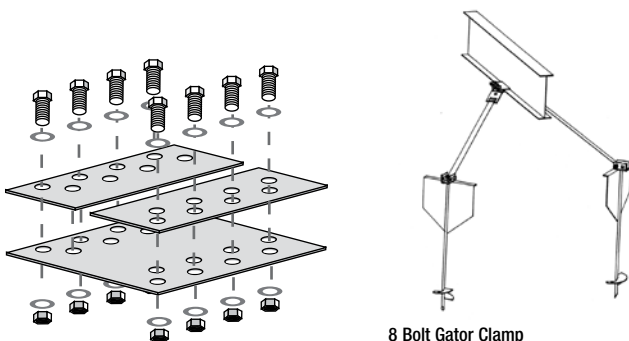

8 Bolt Gator Clamp
(Florida set up shown)

1. Determine anchor/stabilizer plate location and bracket location on I-beam to insure a 45° or lower strap angle.
2. Attach beam clamp with 1/2" Grade 5 bolts and nuts as shown.
3. Connect swivel connector and strap to bolt nearest to anchor with a 1/2" Grade 5 bolt and nut.

Angle Frame Bracket

Part #59009

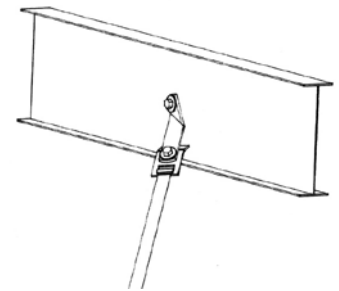

1. Determine anchor/stabilizer plate location and bracket location on I-beam to insure a 45° or lower strap angle .
2. Drill a 1/2" hole, centered in the I-beam as shown. Hole must be a minimum of 4" from any edge of the I-beam.
3. Connect the two Frame Brackets (R & L) with a 1/2" Grade 5 bolt and nut.
4. Attach swivel connector and strap to Angle Frame Brackets with 1/2" Grade 5 bolts and nuts. Tighten all bolts.

NOTE: Frame Brackets must be attached with a Swivel Strap Connector #59002.

INSTALLATION INFORMATION

Frame Tie to Anchor

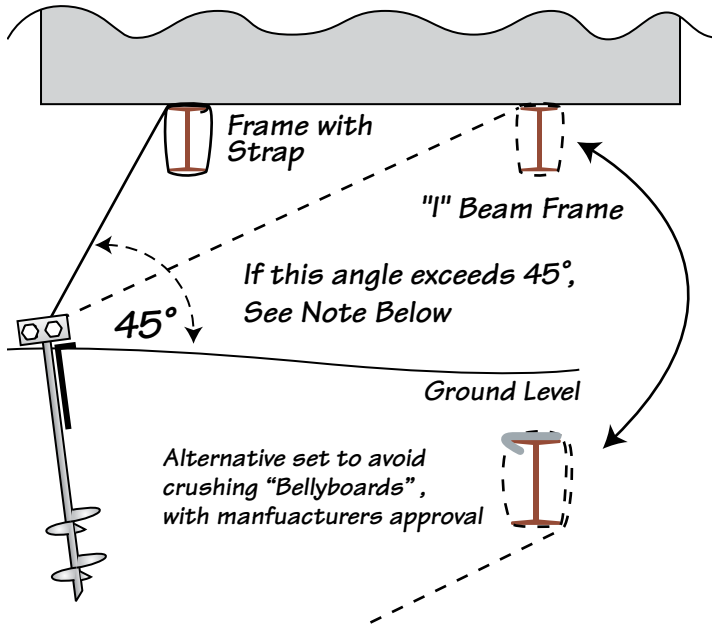

If this angle exceeds 45°, an additional frame clamp (hook) must be attached to the opposite beam as indicated by the dotted line.

A Stabilizer Plate must be installed on all frame Ties. (or alternate method of stabilizing ground anchor.)

Select proper anchor for soil conditions using the Soil Test Probe, or other approved method of determining soil classification.

Frame Tie with Buckle

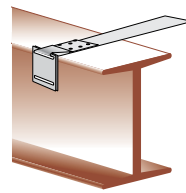

1. Install strap by pushing the end between the inside of the frame "I" beam and the floor.



2. Position the buckle at upper end of the "I" beam frame. Wrap the end of the strap around the "I" beam. Thread the end of the strap through the slot in the buckle as shown. Push the end of strap in-between "I" beam and floor.

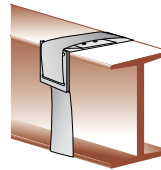

3. Pull the strap, making certain the buckle stays in position. Thread loose end of strap thru slotted tensioning bolt attached to tension head of anchor. Tighten slotted tensioning bolt a minimum of 4 to 5 full turns until all slack in strap is removed.

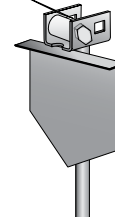

Frame Tie with Hook

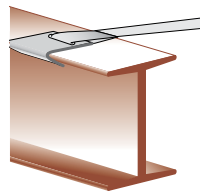

1. Attach frame hook to top inboard location of "I" beam.

2. Keeping in line with the hook, wrap galvanized strap completely around "I" beam.

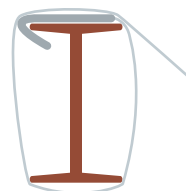

3. Thread loose end of strap through slotted tensioning bolt attached to tension head of anchor. (Anchor must be properly installed into the ground before proceeding with step #4.)

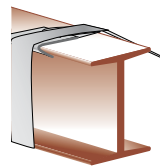

4. Tighten slotted tensioning bolt a minimum of 4 to 5 full turns until all slack in strap is removed.

Strap Buckle - MBU

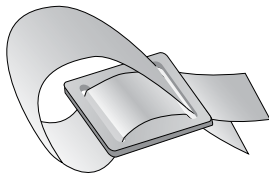

- Thread length of frame tie strap through strap buckle as shown.

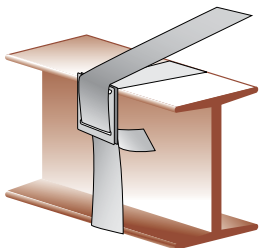

- Next, thread long end of strap between frame and floor of home. Bring strap through buckle as shown in diagram and fasten to anchor head.

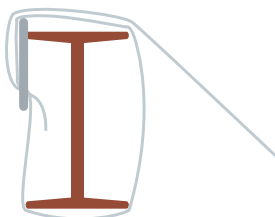

- Diagram shows strap in position around frame and through buckle. It is important to remove all slack from system.

INSTALLATION INFORMATION

Patio Slab Anchor*

This anchor is designed to be inserted through a 3/4" hole drilled or formed into an existing concrete slab.

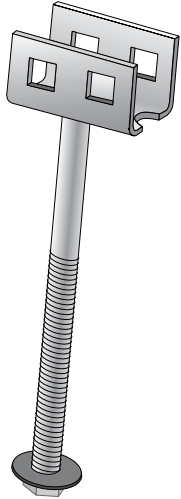

- Concrete must be a 2500 PSI minimum slab with 4" minimum thickness and 6/6 x 10/10 wire mesh or fiber mesh installed.
- Concrete slab must allow 4725 lbs of vertical tension on anchor without lifting. This assumes that the concrete weighs 150 lbs per cu. ft.
- Minimum distance from the anchor shaft to one edge of the slab is 4 in. from one edge and 2 ft. from any other edge.
- If installed in a 4" slab at minimum distances from edges, a layer of 6/6 or 10/10 mesh is recommended.

Concrete Anchor*

The MIJ2 is designed to be installed into a concrete slab at the time the concrete is being poured.

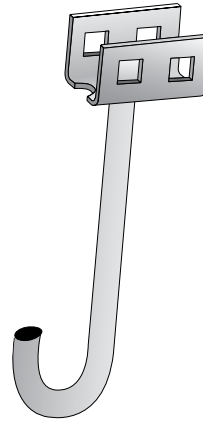

- Concrete must be a 2500 PSI minimum slab with 4" minimum thickness.
- Concrete slab must allow 4725 lbs of vertical tension on anchor without lifting. This assumes that the concrete weighs 150 lbs per cu. ft.
- Minimum distance from the anchor shaft to one edge of the slab is 4 in. from one edge.
- If installed in a 4" slab at minimum distances from edges, a layer of 6/6 or 10/10 mesh is recommended.
- Slab must be 8 in. minimum thickness at location under any anchor to allow 5 in. embedment of anchor "J" rod.

Concrete Slab Anchor*

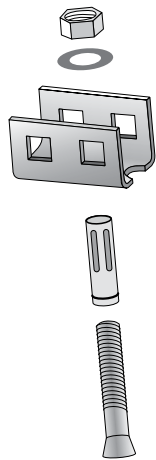

This anchor is designed to be bolted to an expansion sleeve in an existing concrete slab.

- After reviewing restrictions listed to the right, drill a 5/8 in x 3 in. hole in the slab where the anchor head is to be located.
- Place steel expansion sleeve over bolt and place into the drilled hole.
- Place the washer onto the expansion bolt.
- Thread nut onto expansion bolt and tighten until maximum expansion of steel expansion sleeve has been achieved.
- Remove nut and washer and place anchor head over exposed bolt.
- Place washer and nut onto bolt to attach anchor head, tighten nut.
- Concrete must be a 2500 PSI minimum slab with 4" minimum thickness.
- Concrete slab must allow 4725 lbs of vertical tension on anchor without lifting. This assumes that the concrete weighs 150 lbs per cu. ft.
- Minimum distance from the anchor shaft to one edge of the slab is 4 in. from one edge and 6" from any other edge.
- If installed in a 4" slab at minimum distances from edges, a layer of 6/6 or 10/10 wire mesh or fiber mesh is recommended.

*NOTE:

- **Maximum load per anchor is 4725 lbs.**
- **Minimum slab area per anchor for 4725 lbs.:**
 - 4" Thick Slab: 95 S. F.**
 - 6" Thick Slab: 65 S. F.**
 - 8" Thick Slab: 48 S. F.**

INSTALLATION INFORMATION

Cross Drive Rock Anchor - MRA

Engineered for installation into solid rock within 1 in. from bottom of the anchor base. Exact alignment is achieved with the swivel tensioning head.

- Drill 5/8" diameter hole 5-1/2" deep in center of anchor location. Insert pilot stud into hole.
- Drill two 3/4" diameter holes, (the length of the rods) into the rock at 45° angles, using the anchor head as a locating guide.
- Place rod through top and corresponding bottom web flange and into 45° hole. Drive rod into rock. Rod must be driven into rock at least 80% of it's length to achieve minimum allowable pullout resistance. Repeat using 2nd rod.
- Maximum pullout resistance is developed when ground surface is solid rock. Maximum distance from lowest edge of anchor flange to rock surface is 1 in.

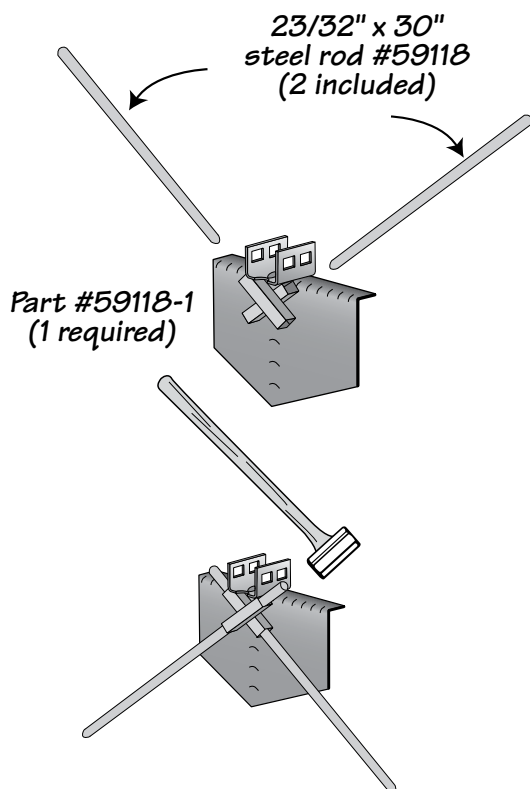
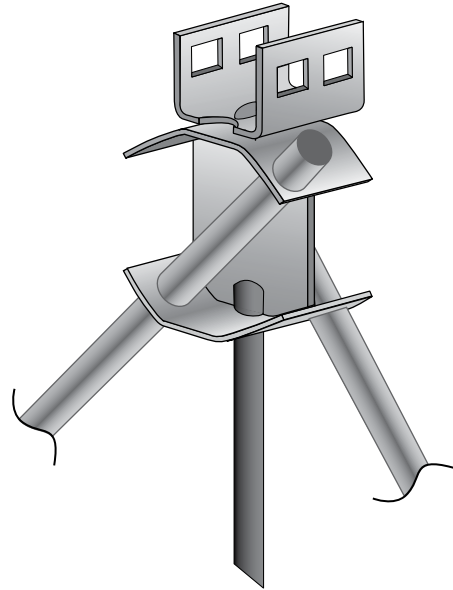

X-Plate Anchor
X-Plate for Soil Class 2
2 - 23/32" x 30" rods included.
Painted Part #59118
Galvanized Part #59118G

X-Plate Anchor with Stabilization Plate

Engineered for installation into difficult ground conditions that, when tested with a soil test probe, exceed 500 in. lbs. (see notes below).

Using a soil test probe, determine the soil classification. Place the X-Plate parallel to the building being secured with the flat plate to the inside. Pound the plate into the ground so that the upper lip is ground level. Using a heavy hammer or electric hammer gun, pound rods into the ground through the box tubing guides welded onto the back side of the stabilizer plate. Rods should be installed until maximum 2" above the box tubing. Install strap as required.

Notes:

1. For Wind Zone 1 use only, max working load of the X-Plate is 2,200 lb. (3,300# ultimate).
2. Difficult Soils Only - Defined as "Extremely hard soil preventing the installation of an auger anchor to its full depth using a 1/2 HP Drive Machine". Torque probe readings at 12" to 18" of the surface must be 500 "# min.
3. Cross drive anchor is NOT rated or intended to be used for direct pull in vertical direction. Angle of resultant load must be at 40-50 degrees from vertical. This anchor may not be appropriate for shear wall or column anchorage.

INSTALLATION INFORMATION

Installation Instructions for ABS Pads

1. Pier spacing must be in accordance with the Home Manufacturer's Installation Manual and/or State or Local requirements.
2. Clear all vegetation and debris from the area where the ABS pads are to be placed.
3. Ground under ABS pads must be leveled and evenly compacted.
4. Place ABS pad with grid side up, smooth side down. Center blocks on ABS pad and complete pier.

Pad Bearing Capacity				
ABS Pad Size	Part#	1000 lbs. Soil	2000 lbs. Soil	3000 lbs. Soil
16" x 18" - 2 Sq. Ft 288 Sq. In.	59300	2,000 lbs.	4,000 lbs.	6,000 lbs.
16" x 22.5" - 2.5 Sq. Ft. 260 Sq. In.	59301	2,500 lbs.	5,000 lbs.	7,500 lbs.
17" x 25" - 3 Sq. Ft 432 Sq. In.	59302	3,000 lbs.	6,000 lbs.	N/A
24" x 24" - 4 Sq. Ft 576 Sq. In.	59303	4,000 lbs.	8,000 lbs.	N/A

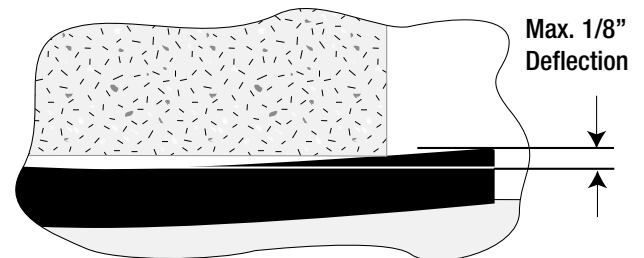
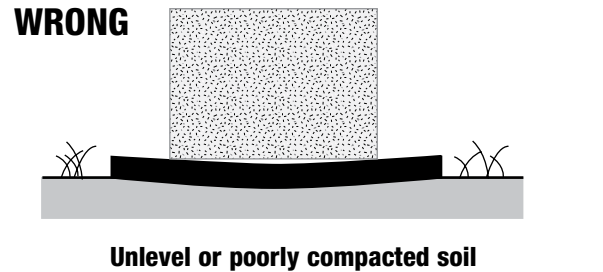
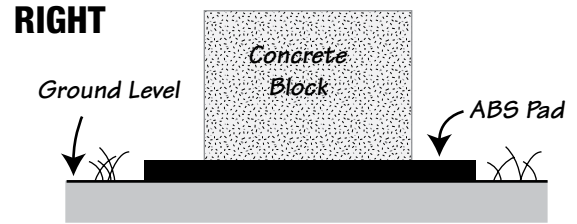

Deflection is measured from the highest point to the lowest point of the top side of the pad.

Adjustable Outrigger/Diagonal Strut Installation Instructions

1. Determine floor joist area needing support.
2. Set mounting plate on floor joist and secure with 5 (#12x2") screws provided. Approx. 6" from outer rim joist.
3. Insert threaded bolt in support tube and adjust so it clears I-beam flange when mounting plate is inserted and chisel end of bolt is placed against the frame. If support tube is too long, simply cut square to desired length.
4. Raise floor joist with jack to desired level before tightening the nut on the threaded bolt, snug fit to 1/4 turn past.
5. Replaces perimeter piers required for window and door support and alignment, except as required by the home manufacturer for larger openings.
6. For manufactured homes only, built to Federal Manufactured Home Construction & Safety Standards.
7. The total allowable load is 864 pounds, (liveload 665 pounds), which is the load at each side of a 46-1/2" sidewall opening in a 30 PSF roof zone for a roof tributary of 8'-6" (e.g. a 180" unit width a 12' eaves).

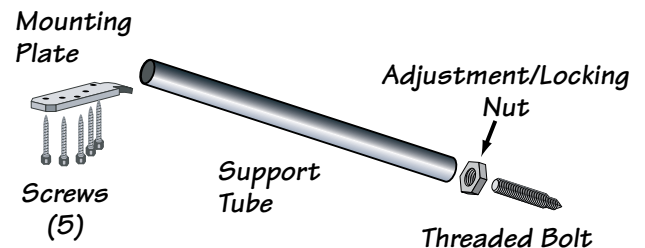
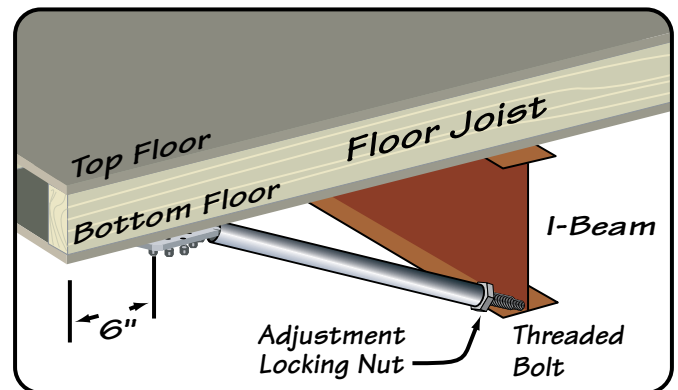

Do not use on homes while being transported.

NOTE: This component is not designed or intended to replace any foundation supports required by the home's manufacturer and is not a repair for damaged joists.

Soil Classification Chart

Ground anchors are designed for different soil classifications: longer models for loose soils, shorter models for harder soils. Prior to installing any ground anchor model, the soil must be tested (with a Soil Test Probe) in order to match approved ground anchor model with site soil class.

WARNING: Before ground anchor installation, determine that the anchor locations around home will not be close to any underground electrical cables, water lines or sewer piping. Failure to determine the location of electrical cables may result in serious personal injury.

Soil Test Probe

The Soil Test Probe is used to determine the soil conditions below the surface near the anchor's helix. Using the Soil Test Probe will ensure maximum anchor holding strength by indicating the proper anchor model for each soil condition.

Using the chart provided, a probe reading can be converted to the recommended anchor for every soil condition.

Instructions

- Place probe tip into ground where you intend to place the anchor. Using a 15/16" hex socket with a ratchet or breaker bar, rotate the probe in a clockwise direction. (An electric drive machine with an adaptor head may also be used)
- Drive (rotate) the torque probe into the soil until reaching a depth equal to the length of the anchor being installed.
- To determine the soil classification:
 - Place wrench adaptor onto torque wrench.
 - Insert hex portion of wrench adaptor onto the earth probe.
 - Support probe shaft with one hand, while rotating probe steadily with the wrench. (Do not exceed 600 in. lbs.)
 - Read the torque wrench while rotating probe clockwise.
 - Use the soil classification chart to cross reference probe readings. Color codes match those printed on Tie Down's torque probe.
- If probe reading does not match the anchor for that depth, rotate probe to next anchor depth and check reading. Continue until reading on probe matches anchor length for depth of reading.
- To remove probe, use wrench or electric drive machine in reverse (counter clockwise).

Soil Class	Test Value (in. lbs.)	Soil Description
1	N/A	Sound hard rock.
2	550 +	Very dense and/or cemented sands, coarse gravel, cobbles, preloaded silts, clays and coral.
3	350 to 550	Medium dense coarse sands sandy gravels very stiff silts and clays.
4a	275 to 350	Loose to medium dense sands, firm to stiff clays and silts, alluvial fill.
4b	175* to 275	Loose sands, firm clays and silts, alluvial fill.

* Below 175 in. lbs., a professional engineer should be consulted

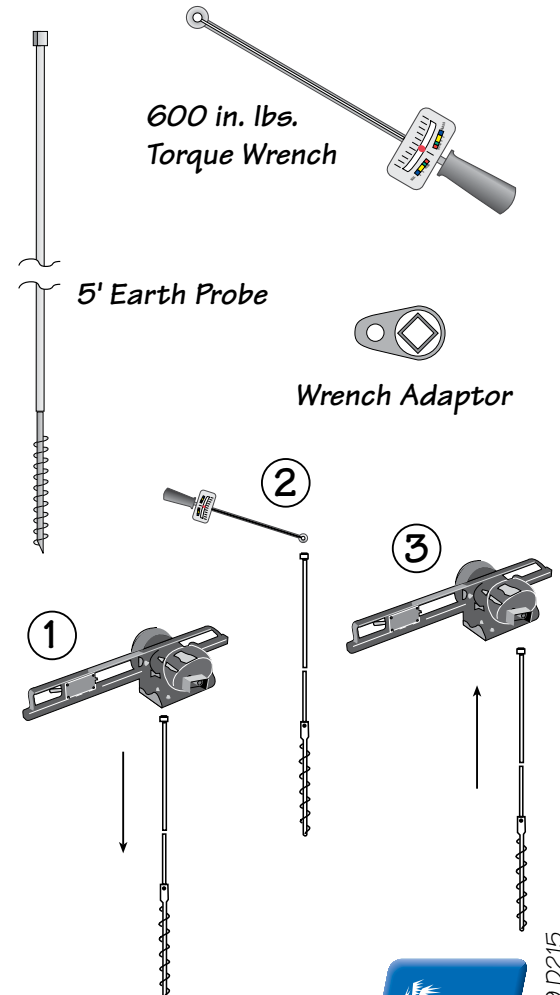

NOTE: Each State, County or Municipality may require a specific anchor from the groups shown for each soil classification. Check local and State regulations first.

Anchor Chart

Soil Class & Test Values (in. lbs.)	Recommended Anchor / Stabilizers	TDE Part Number Black/Galvanized	
<div style="border: 1px solid black; padding: 5px; display: inline-block; width: 30px; height: 30px; text-align: center; line-height: 30px;">1</div> <div style="margin-left: 10px;">N/A</div>	30" Cross Drive Rock Anchor	59110	59110G
	48" Cross Drive Rock Anchor	59111	59111G
<div style="background-color: #000080; color: white; padding: 5px; display: inline-block; width: 30px; height: 30px; text-align: center; line-height: 30px;">2</div> <div style="margin-left: 5px; font-size: 8px;">Blue</div> <div style="margin-top: 10px;">550 lbs +</div>	30" X 5/8" rod / 2 - 4" helix	59090	59078
	30" X 3/4" rod / 2 - 4" helix	59095	59079
	60" X 3/4" rod / 2 - 4" helix	59097	59097G
	All anchors above should use one of the following when subjected to lateral loads:		
	12" Stabilizer Plate	59292	59292G
	Quik-Set Stabilization Plate	59291	59291G

	X-Plate Anchor with 2-23/32" Rods	59118	59119
<div style="background-color: #ffff00; color: black; padding: 5px; display: inline-block; width: 30px; height: 30px; text-align: center; line-height: 30px;">3</div> <div style="margin-left: 5px; font-size: 8px;">Yellow</div> <div style="margin-top: 10px;">350 to 550 lbs.</div>	48" X 5/8" rod / 1 - 6" helix	59080	59081
	48" X 3/4" rod / 1 - 6" helix	59085	59094
	36" X 3/4" rod / 1 - 6" helix & 1 - 4" helix	59250	59250G
	All anchors above should use one of the following when subjected to lateral loads:		
	12" Stabilizer Plate	59292	59292G
	Quik-Set Stabilization Plate	59291	59291G

	Deepset Anchor 30" X 5/8" rod / 2 - 4" helix	59091	59091G
<div style="background-color: #008000; color: white; padding: 5px; display: inline-block; width: 30px; height: 30px; text-align: center; line-height: 30px;">4a</div> <div style="margin-left: 5px; font-size: 8px;">Green</div> <div style="margin-top: 10px;">275 to 350 lbs.</div>	48" X 5/8" rod / 1 - 6" helix	59080	59081
	48" X 3/4" rod / 1 - 6" helix	59085	59094
	36" X 3/4" rod / 1 - 6" helix & 1 - 4" helix	59250	59250G
	3/4" rod, 42" long, 2- 4" helix, Class 4A	59128	59128G
	3/4" rod, 48" long, 2-4" helix, Class 4A	59086	59086G
	All anchors above should use one of the following when subjected to lateral loads:		
	12" Stabilizer Plate	59292	59292G
	17 -1/2" Stabilizer Plate (Florida Only)	NA	59286
Quik-Set Stabilization Plate	59291	59291G	
ABS Stabilization Plate (Florida Only)	59293	NA	

	Deepset Anchor 36" X 3/4" rod / 4" & 6" helix	59092	59092G
<div style="background-color: #ff0000; color: white; padding: 5px; display: inline-block; width: 30px; height: 30px; text-align: center; line-height: 30px;">4b</div> <div style="margin-left: 5px; font-size: 8px;">Red</div> <div style="margin-top: 10px;">175 to 275 lbs.</div>	60" X 3/4" rod / 1 - 7" helix	NA	59099
	All anchors above should use one of the following when subjected to lateral loads:		
	17 -1/2" Stabilizer Plate	NA	59286
ABS Stabilization Plate	59293	NA	

NOTE: Each State, County or Municipality may require a specific anchor from the groups shown for each soil classification. Check local and State regulations first.