



"AT" SERIES ELECTRIC HOT WATER BOILERS FOR FORCED HOT WATER

INSTALLATION, OPERATION & MAINTENANCE MANUAL



An ISO 9001-2008 Certified Company
ECR International, Inc.
2201 Dwyer Ave
Utica, NY 13501

Information and specifications outlined in this manual in effect at the time of printing of this manual. ECR International reserves the right to discontinue, change specifications or system design at any time without notice and without incurring any obligation, whatsoever.





TABLE OF CONTENTS

Safety Symbols 2
 Warnings..... 2
 Introduction..... 3
 Product Description..... 3
 Voltage Rating Tables 4
 Installation Procedure 5
 Design of Water Circulating System 6
 Connecting Supply and Return Piping 6
 Connecting Electrical Power Supply 8
 Wiring Diagrams..... 11
 Thermostat Installation 15
 Startup and Seasonal Maintenance 15
 Troubleshooting..... 16
 Maintenance 17
 Parts List - 2 Element Electric Boilers 18
 Parts List - 4 Element Electric Boilers 19
 Additional Wiring Diagrams 20
 Modular Boiler Piping 23
 Troubleshooting..... 24
 "AT" Series Boiler Dimensions 27
 Homeowner's Reference Table 28

SAFETY SYMBOLS

Following symbols are used throughout this manual to notify reader of potential hazards of varying risk levels.

 **DANGER**
 Indicates an imminently hazardous situation which, if not avoided, WILL result in death, serious injury or substantial property damage.

 **WARNING**
 Indicates an imminently hazardous situation which, if not avoided, may result in death, serious injury or substantial property damage.

 **CAUTION**
 Indicates an imminently hazardous situation which, if not avoided, may result in injury or property damage.

NOTICE
 Indicates information which should be followed to ensure proper installation and operation.

NOTICE

Read the following instructions completely before installing!!

WARNING

 **BOILER SIZING IS CRUCIAL.** The maximum hourly heat loss for each heated space should be calculated in accordance with procedures describes in The Hydronics Institute (I=B=R) manual H-22 (Heat Loss Calculation Guide), or by any other method which is suitable for local conditions, provided the results are in substantial agreement. Select appropriate boiler based on accurate heat loss calculation. **DO NOT OVERSIZE BOILER, AS SIZING IS CRITICAL FOR IN-FLOOR RADIANT HEAT APPLICATIONS.**

Keep boiler area clear and free from combustible materials, gasoline and other flammable vapors and liquids.

Do not obstruct air openings to boiler room.

Modification, substitution or elimination of factory equipped, supplied or specified components may result in property damage, personal injury or loss of life.

NOTICE

Owner: Installation and service of this boiler must be performed by qualified installer.

Installer: Leave all instructions with the boiler for future reference.

When this product is installed in the Commonwealth of Massachusetts installation must be performed by licensed plumber or licensed gas fitter.*

* In other areas, consult authority having jurisdiction.

**KEEP THIS MANUAL NEAR BOILER
 RETAIN FOR FUTURE REFERENCE**

WARNINGS

WARNING



Installation of boiler should be done only by qualified expert and in accordance with appropriate installation manual. Installing boiler or any other electric appliance with improper methods or materials may result in serious injury or death due to fire.

INTRODUCTION

Manual is intended to familiarize installer and user of Electric Hydronic Block with its installation, operation and maintenance to assure its normal trouble free operation.

Argo electric boilers are designed and manufactured with quality components for maximum life, durability and minimum service. Follow installation instructions carefully before operating heating system for optimum efficiency and satisfaction. Failure to do so may result in breach of warranty.

PRODUCT DESCRIPTION

Electric Hydronic Block is heating device converts electrical energy to heat energy through medium of water. Simplified theory of this conversion is as follows:

$$\text{Electrical Energy} \times \text{Conversion Factor} = \text{Energy} \\ \text{— Or —}$$

$$\text{Kilowatts Of Electricity Used Per Hour} \times 3412 = \\ \text{British Thermal Units (Btuh) Available Per Hour For} \\ \text{Heating.}$$

Information is basis used to establish Electric Hydronic Block ratings (See Table 1 on page 4). Since conversion process requires no combustion, boiler operates with highest possible efficiency.

Electric Hydronic Block is constructed with cast iron boiler that conforms to American Society of Mechanical Engineers (ASME) Boiler & Pressure Vessel Code. Interior design allows just enough water to be present for proper heating element operation - no excess water is stored which would cause undesirable thermal losses and longer recovery times.

Control system is assembled in modular package keeping overall size and weight of Electric Hydronic Block to minimum. Construction of entire Electric Hydronic Block conforms to Canadian Standards Association (CSA) Standards for Safety for Electric Boilers.

Following important product information is located on cabinet cover:

- Model Number
- Manufacturer's Serial Number
- BTU Rating
- Heating Element Ratings
- Water Pressure & Temperature Limits
- CSA Listing
- ASME Stamp
- Total Amps
- Clearance

Argo Electric Boilers are controlled by electronic control board maintaining water temperature. Control cycles heating elements based on heating demand, and preset boiler outlet water temperature. Control also operates 120Vac circulating pump rated up to 5A. When thermostat calls for heat, control will operate boiler to regulate water temperature at pre-selected set point. System pump is on whenever thermostat calling for heat.

Table A

AT Boiler Electrical Specifications

Operating at 240 Vac														
"AT" Series - 2 Element Boiler											* Recommended Wire			
Model	Boiler Size Nominal kW	Voltage (AC)	Output Power (Watts)	Output Power BTU/Hr.	Amperage	Element Size (Watts) at 240Vac	Number Elements	Accessory Load (A)	Total Amps	MCA	MOP	60°C (140°F) AWG	75°C (167°F) AWG	90°C (194°F) AWG
AT1623	6	240	6,000	20,500	25.0	3,000	2	6	31.0	38.8	40.0	8	8	10
AT0824	8	240	8,000	27,300	33.3	4,000	2	6	39.3	49.2	50.0	6	8	8
AT1025	10	240	10,000	34,100	41.7	5,000	2	6	47.7	59.6	60.0	4	6	6
AT1226	12	240	12,000	41,000	50.0	6,000	2	6	56.0	70.0	70.0	4	4	6
"AT" Series - 4 Element Boiler														
AT1243	12	240	12,000	41,000	50.0	3,000	4	6	56.0	70.0	70.0	4	4	6
AT1644	16	240	16,000	54,600	66.7	4,000	4	6	72.7	90.8	100.0	2	3	4
AT2045	20	240	20,000	68,200	83.3	5,000	4	6	89.3	111.7	125.0	1/0	2	2
AT2446	24	240	24,000	82,000	100.0	6,000	4	6	106.0	132.5	150.0	2/0	1/0	1
Operating at 208 Vac														
"AT" Series - 2 Element Boiler											* Recommended Wire			
AT0623	6	208	4,507	15,400	21.7	3,000	2	6	27.7	34.6	35.0	8	10	10
AT0824	8	208	6,009	20,500	28.9	4,000	2	6	34.9	43.6	45.0	6	8	8
AT1025	10	208	7,511	25,600	36.1	5,000	2	6	42.1	52.6	60.0	6	6	8
AT1226	12	208	9,013	30,800	43.3	6,000	2	6	49.3	61.7	70.0	4	6	6
"AT" Series - 4 Element Boiler														
AT1243	12	208	9,013	30,800	43.3	3,000	4	6	49.3	61.7	70.0	4	6	6
AT1644	16	208	12,018	41,000	57.8	4,000	4	6	63.8	79.7	80.0	3	4	4
AT2045	20	208	15,200	51,200	72.2	5,000	4	6	78.2	97.8	100.0	1	3	3
AT2446	24	208	18,027	61,600	86.7	6,000	4	6	92.7	115.8	125.0	1/0	1	2

MCA = Minimum Circuit Ampacity

MOP = Maximum Over-current protection

*Recommended Field Wire Size per NEC Table 310.16

Not more than three (3) current carrying conductors in raceway

Based on ambient temperature of 30°C (86°F). Other ambient temperatures see NEC or CEC for correction factors.

Use Copper conductors only.

Recommended use only Class B or C type wire (see Table B).

Check with latest version of NEC and local codes. UL-834, Section 14.2

Assuming 60°C (140°F) wire will be used for connections to boiler rated at 80 amperes or less, and 75°C (167°F) wire will be used with boiler rated at more than 80 amperes.

INSTALLATION PROCEDURE

Improper installation, adjustment, alteration, service or maintenance can cause injury or property damage.

1. Installation must conform to requirements of authority having jurisdiction or, in absence of such requirements, to Canadian Electrical Code, CSA C22.1 Part 1, and/or any local regulations in Canada, or National Electrical Code, ANSI/NFPA to (Latest Edition) and/or any local regulations and codes in the USA. Reference should also be made to local Electric utility regulations and other codes in effect in the area in which installation is to be made.
2. Where required by authority having jurisdiction, installation must conform to American Society of Mechanical Engineers Safety Code for Controls and Safety Devices for Automatically Fired Boilers, ANSI/ASME No. CSD-1.
3. **Boiler is intended for indoor installation only and not subject to water spray or leakage.**

Install unit with minimum clearance from top of unit to ceiling of 16 inches. If minimum requirements of space are used, suggested enclosure be exposed to means of ventilation. Electric Hydronic Block unit must be mounted level, using top of back plate as leveling point.

6. When installed in utility room, door should be wide enough to allow largest boiler part to enter, or to permit replacement of another appliance such as water heater.

Minimum clearances to combustible constructions are:

TOP	16 IN.
FRONT	12 IN.
LEFT SIDE.....	20 IN.
RIGHT SIDE	20 IN.
REAR.....	0 IN.
BOTTOM.....	10 IN.

CAUTION



Do not install boiler under potential water source.

(RULE OF THUMB: Water Under Wires.)

4. Electric Hydronic Block units are provided with mounting brackets for easy wall mounting. Use of lag screws or anchor bolts through holes provided, or on 3/4" plywood panel. On uneven walls, suggested mounting surface be provided such as two 2 x 4's.
5. Surface of Electric Hydronic Block except back shall be mounted no closer than 20 inches to wall surface on left and 20 inches minimum to wall surface on right or more, depending on plumbing. Allow sufficient room from front of unit to door or wall to remove cover - at least 12 inches minimum.

BOILER LOCATION & CLEARANCE DIMENSIONS

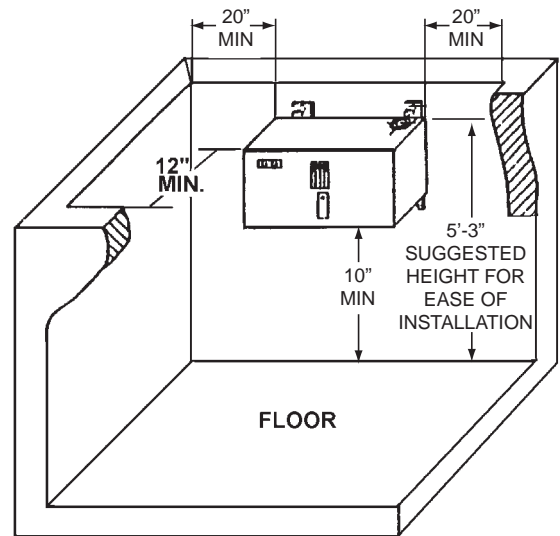

NOTE: Greater clearances for access should supersede fire protection clearance.

DESIGN OF WATER CIRCULATING SYSTEM

System should be designed as primary/secondary piping and to operate with a maximum output temperature of 180°F or lower and a temperature rise across the unit of 20°F or lower. Refer to tables below and Figures 2 & 3.

NOTICE

Return water temperature must be higher than room temperature in which boiler is installed to prevent condensation.

“AT” Series - 2 Element Boiler	
KW Capacity	Minimum Flow Rate (GPM)*
6	2.0
8	2.7
10	3.4
12	4.1

“AT” Series - 4 Element Boiler	
KW Capacity	Minimum Flow Rate (GPM)*
12	4.1
16	5.5
20	6.8
24	8.2

* Flow rate based on 20°ΔT

CONNECTING SUPPLY AND RETURN PIPING

1. Maintain minimum clearance of one inch to hot water pipes.
2. Hot water boilers installed above radiation level must be provided with low water cutoff device either as part of boiler or at time of boiler installation.

NOTICE

In some states low water cutoff device (LWCO) may be required. Check your local codes.

3. When boiler is connected to heating system utilizing multiple zone circulators, each circulator must be supplied with flow control valve to prevent gravity circulation.

NOTICE

Reduced pressure back flow preventer must be present under provisions required by Environmental Protection Agency, (EPA).

4. Suggested plumbing arrangements are illustrated in Figures 2 & 3. Inlet or return pipe is located at bottom of unit. Reverse flow will result in noisy operation and cause very early element failure. Drain cock is to be located at lowest point of piping.
5. Outlet or supply pipe line to radiation is located at top of unit. Combination temperature pressure (altitude) gauge is provided with each unit and should be installed close to boiler outlet. It is important gauge sensor be completely immersed in flowing water to assure correct temperature readings. Manual or automatic water make up supply may be located in this area below. Circulator pump should be installed on supply side (pumping away).
6. Install gate valves at locations shown in Figures 2 & 3, so any boiler servicing requiring removal of water can be done quickly and easily. Not illustrated but recommended is installation of air vents at high points of hydronic system. Devices will reduce initial start up time and help avoid element burnout during entire life of heating system.
7. Pressure relief valve is supplied with each Electric Hydronic Block and should be installed at the location and discharge direction shown in **Figure 1**, using pipe nipple and elbow supplied. Piping should be added so that any water discharged will not damage boiler or other system components.

FIGURE 1

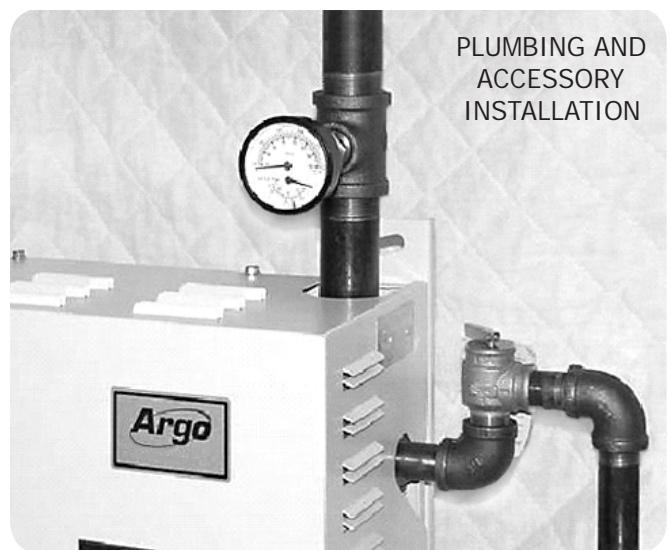

8. For further piping information refer to Hydronics Institute (I=B=R) manual 200 (Installation Guide for Residential Hydronics).

PRIMARY/SECONDARY PIPING

FIGURE 2

PRIMARY/SECONDARY PIPING FOR MULTIPLE ZONING WITH CIRCULATORS

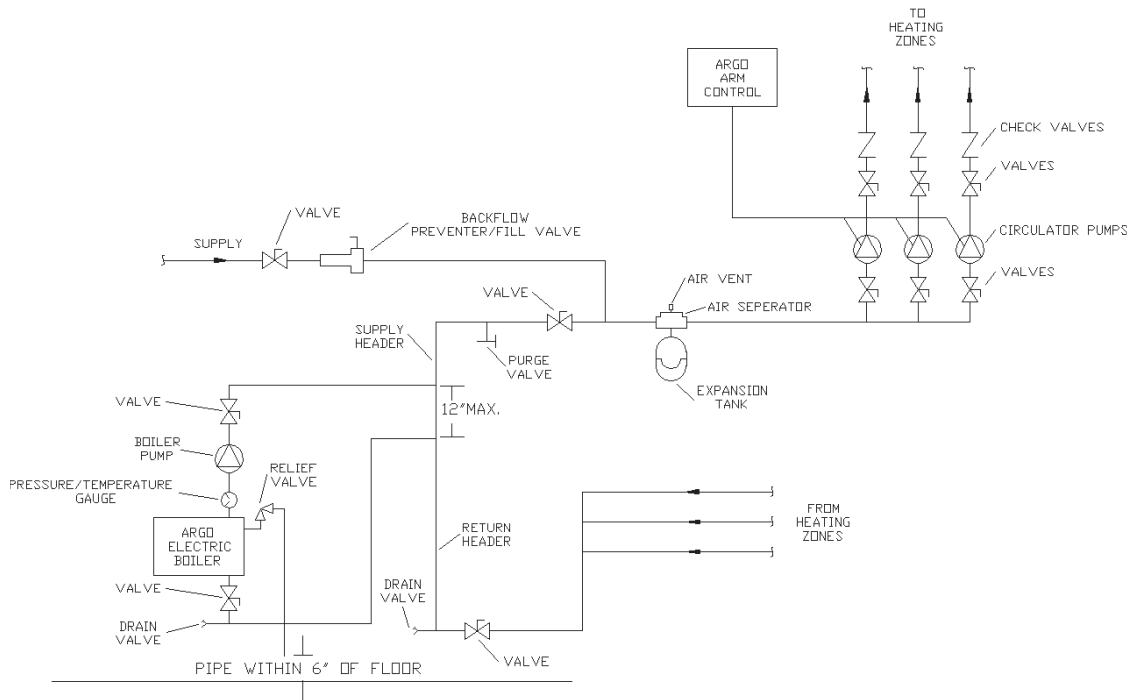
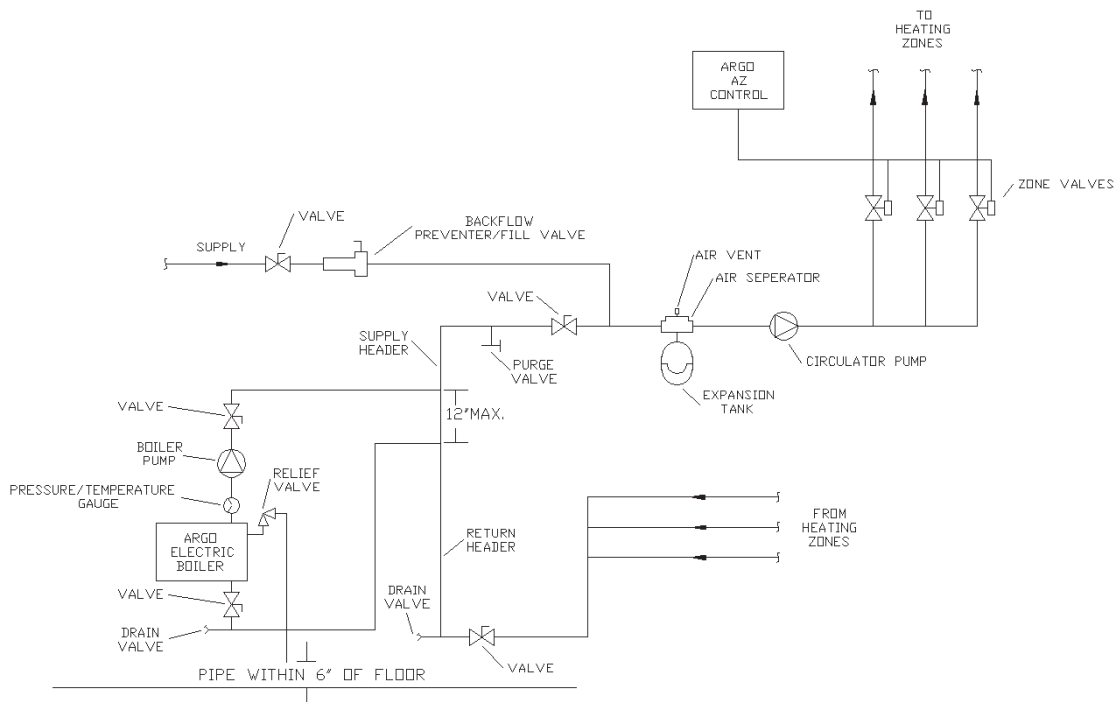

FIGURE 3

PRIMARY/SECONDARY PIPING FOR MULTIPLE ZONING WITH ZONE VALVES



CONNECTING ELECTRICAL POWER SUPPLY

WIRING THE BOILER



WARNING

Do not use aluminum wire!!

Argo Electric Hydronic Boilers are pre-wired for use with 240-volt, 3 wire, single-phase, 50/60-hertz power. See Table A on page 4 for reduction in boiler capacity when line voltage is less than 240 volts.

Opening provided in jacket bottom panel for field wiring, refer to rating chart for recommended wire sizes.

Electrical wiring shall be done in accordance with Canadian Electrical Code, CSA C22.1 Part 1, authority having jurisdiction in Canada, or National Electrical code, ANSI/NFPA 70 and/or authority having jurisdiction in USA. Verify nameplate rating and check related codes to properly size conductors, switches and over current protection. Several openings are provided on bottom of cabinet for different voltage connections. Wire connections refer to wiring diagram on inside of boiler front cover.

All circuit breakers or disconnects ahead of boiler must be OFF. If boiler contains integral breakers (depending on option), it is recommended they are also turned off at this time. Remove boiler front cover by removing 4 screws from top and sides.

If boiler is used in multiple zone system, the zone valves must be powered from independent source and have electrically isolated end switches or isolating relays wired in parallel to boiler thermostat terminals. **Do not attempt to power zone valves from transformer in boiler control system!!**

FIELD WIRING

- All Field wiring shall be in accordance with NEC or CEC standards. Minimum Circuit Ampacity (MCA) and recommended Maximum Overcurrent Protection (MOP) are listed on nameplate of unit, see Table A.
- Use Copper conductors only.
- Use only Class B or C Stranded wire. See Table B.
- Wire Strip Length: 11/16" (Minimum). (Refer to field wiring diagram).
- Wire must be fully inserted into terminal block, touching back of entrance hole.
- Field terminal wire lugs shall be tightened in accordance with manufacture's recommended torque specifications using appropriate torque wrench. Proper torque settings are listed on terminal block, see Table C.
- Hex head wrench size required for Terminal Block: 5/16". For Circuit Breaker: Flat Screwdriver.
- Do not use wire grease on wire termination connections and terminal block. This will change torque properties. The Terminal block was not tested or approved using wire grease.

- Hold lug at specified torque for 5 seconds before releasing. When tightening this will ensure any cold flow of material is compensated for.

FIELD WIRING DIAGRAM

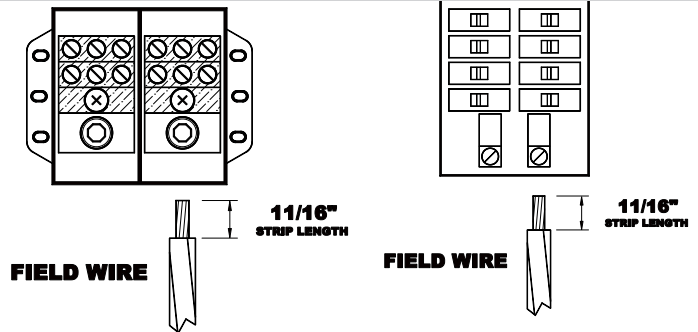

TERMINAL BLOCK

CIRCUIT BREAKER

Wire Classes - Table B		
Wire Size AWG	Number of Concentric Strands	
	Class B	Class C
10	7	19
8	7	19
6	7	19
4	7	19
3	7	19
2	7	19
1	19	37
1/0	19	37
2/0	19	37

Class B - Power cables
Class C - Power cables where more flexibility is desired

Field Wire Line Side Torque Specifications - Table C

Wire Size (AWG)	Torque requirements (in LBS)
2/0-6	120
8	40
10-14	35

WIRING ON CONTROL

PUMP: Connect only 120 Vac 1/6 HP (maximum) pump to terminals C1(L) and C2(N) on controller. Strip wire ends before inserting into terminal block. Tighten terminal screws. **Do not use pump rated greater than 5 amps!!**

THERMOSTAT: Connect thermostat or zone valve end switch to terminals TT and TT (*Figure 4*). **Do not apply external power source to terminals!!** Strip wire ends before inserting into terminal block. Tighten terminal screw clamps.

FIGURE 4

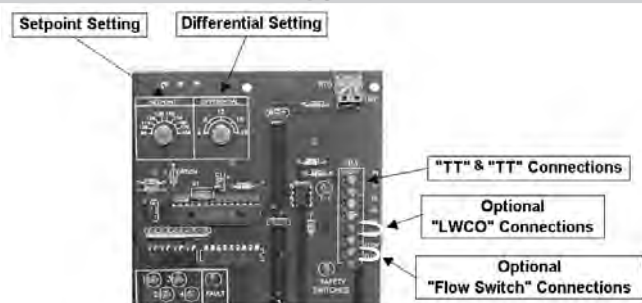

CONNECTING ELECTRICAL POWER SUPPLY

FIGURE 5

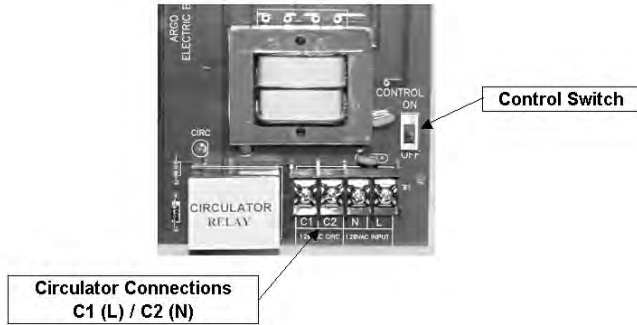

LIMIT CONTROL OPERATION

1. When boiler water temperature exceeds high limit setting on aquastat, all heating element control relays are instantly de-energized. Circulator continues to operate until call for heat ends. When water temperature drops below aquastat re-set differential, heating element power relays close as per time delay sequence.
2. **MAIN POWER SUPPLY:** Depending on model designation, the electric Hydronic Block may be energized by following alternating current service entrances: 240 volt single phase 50 or 60 cycle 3 wire. Wire size see Table A. Sizes listed for various capacity units include total amperes necessary to operate elements, circulator and zone valves where used. Wire sizes specified conform to Canadian Electrical Code (Canada) or National Electric Code (USA) and include derating for ampacity and temperature. **Use copper wire only.** Check state and local requirements.

Read data name plate before connecting unit. Electrical connections are provided and located for proper installation.

Use only copper wire of proper size and make sure all terminations are tight. **Do not use aluminum wire!!**

3. **CIRCULATOR POWER SUPPLY:** Terminals identified as C1(L) and C2(N) at bottom of control panel (Figure 5) may be used to supply one circulator pump power. Circulator motor shall not be larger than 1/6 horsepower with maximum 5.0 amp rating. Wiring from control panel to the pump should have insulation rated 75°C. Circuit protection is provided by 15 amp breaker or fuse (depending on option) on control board.

NOTE: If circulator pump is larger than maximum size listed above, separate circulator pump relay must be provided with separate overload protection. Where more than one circulator is used for zoning, it must be installed and protected according to approved electrical codes.

CONTROL INFORMATION

CONTROL BOARD POWER CONSUMPTION:

0.8A max.

LED DISPLAY LIGHTS (Figure 6):

A total of 8 LED indicator lights display the following information:

1. T-T (Green): LED lit when thermostat calling for heat.
2. Fault (Red): LED lit/flashes operating error/safety fault.
3. Safety Switch (Green): LED no safety faults.
4. Circ (Green): LED circulator terminals are energized.
5. Heating Element#1 (Green): LED element#1 is energized.
6. Heating Element #2 (Green): LED element #2 is energized.
7. Heating Element #3 (Green): LED element #3 is energized.
8. Heating Element #4 (Green): LED element #4 is energized.

FIGURE 6

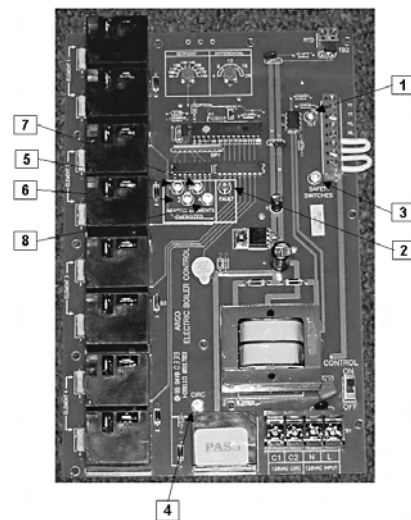

SIGNAL/CONTROL INPUTS:

TT: Thermostat or zone valve end switch, switching input, closed activation.

HL: High limit temperature sensors (factory installed), normally closed.

LWC: Low water cutoff (optional) end switch, normally closed (factory installed jumper).

FLOW: Flow switch (optional) end switch, normally closed (factory installed jumper).

CONTROL BOARD SPECIFICATIONS:

- **Dimensions:** 5-7/8" (W) x 9-3/8" (L) x 1-5/8" (H)
- **Operating Control Outlet Water Temperature:**
90°F - 180°F (adjustable)
- **High Limit Control Outlet Water Temperature:**
200°F (fixed)
- **Control Input Voltage:** 120V ac
- **Control Output Voltage:** 120V ac, 5A max. (circulator terminal)
- **POWER OUTPUT:** 120V ac pump output is switched by onboard circulator relay. Load current limited must not exceed 5A.

TEMPERATURE CONTROL RANGES:

Temperature: Degrees Fahrenheit

Operating Temperature Range:

90°F - 180°F

(Factory Setting: 180°F)

Operating Temperature Differential Range:

+/- 4°F - +/- 20°F

(Factory Setting: 12°F)

Fixed High Limit Temperature: 200°F

OPERATING TEMPERATURE AND DIFFERENTIAL ADJUSTMENTS: Internal temperature potentiometer on control.

CONTROL OPERATION: Control switch "On" position and safety end switches are closed, "Safety Switch" LED is lit. Once in operating mode, control uses well-mounted (RTD) sensor to continuously monitor water temperature.

Thermostat calls for heat ("TT" LED is lit), control will energize circulator ("Circ" LED is lit) for 30 seconds to establish flow. Control will then measure water temperature and differential setting, perform check for "open" or "shorted" RTD sensor, verify all safety end switches are "closed," check for stuck or welded element relay contacts. Next, control will energize only one element ("Element" LED is lit) and monitor water temperature for 60 seconds. Control will energize additional elements at 30 second intervals to bring system up to set point temperature in 5 minutes.

Once system reaches set point temperature and there is still call for heat, control will modulate number of elements on and off in order to maintain set point temperature. Required number of elements energized is determined by heating demand, which is difference between actual boiler water temperature

and set point temperature.

After call for heat has been satisfied, elements will de-energize ("Element" LEDs turn off) by control **and circulator will continue to be energized for 3 minutes to purge boiler**. After 3 minutes control will de-energize circulator ("Circ" LED turns off).

If during start-up or during operation safety end switch opens its respective contact, control de-energizes all elements, continues to energize circulator, and flashes visible fault code ("Fault" LED flashes) along with audible fault code. (See fault codes (below)) Control has built-in reset function.

TEMPERATURE SETTING: Water "Set point" temperature adjustment dial on control should be set at designed boiler water temperature.

CONTROL MOUNTING: Control mounted using 1/2" tall plastic standoffs. Indicator LEDs are visible through clear polycarbonate viewing window on front cover.

PROTECTION FROM LIQUIDS: Control and other components located within control panel are sensitive to water and other liquids. Protect components on panel from contact with liquids.

FAULT CODES (VISUAL/AUDIBLE)

Number of Flashes/ Pulses	Description
1	Safety switch fault
2	Stuck/welded element relay contact
3	RTD short
4	RTD open

RTD SENSOR:

Verify RTD sensor is functioning properly, follow steps below.

1. Remove both RTD leads from terminal block control board.
2. Use multimeter to take ohm reading across RTD leads. Properly functioning RTD will produce reading of approximately 1000 ohms at 70°F. Faulty RTD will read either 0 or 1 on multimeter.
3. Replace RTD if necessary.

FIGURE 7A

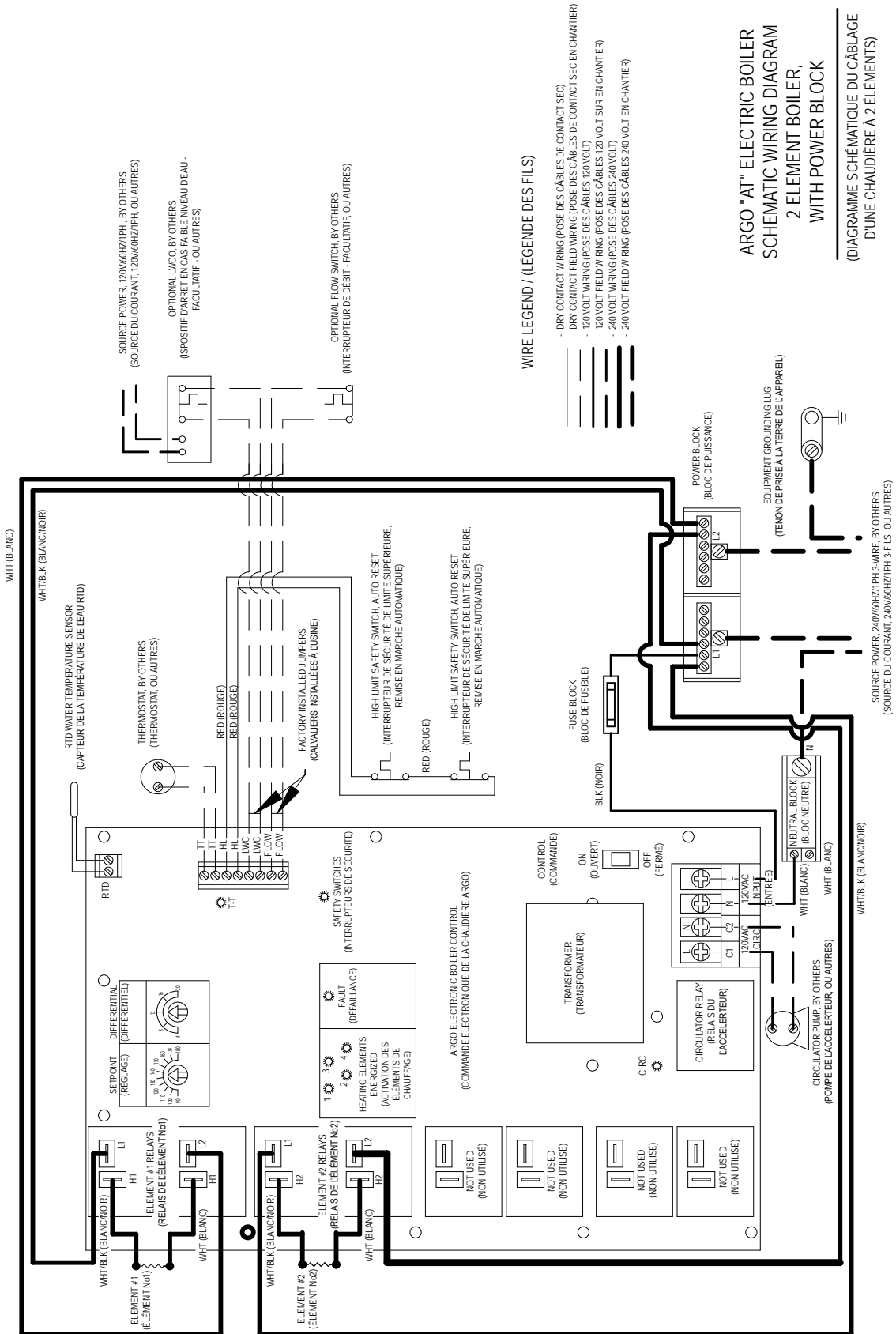
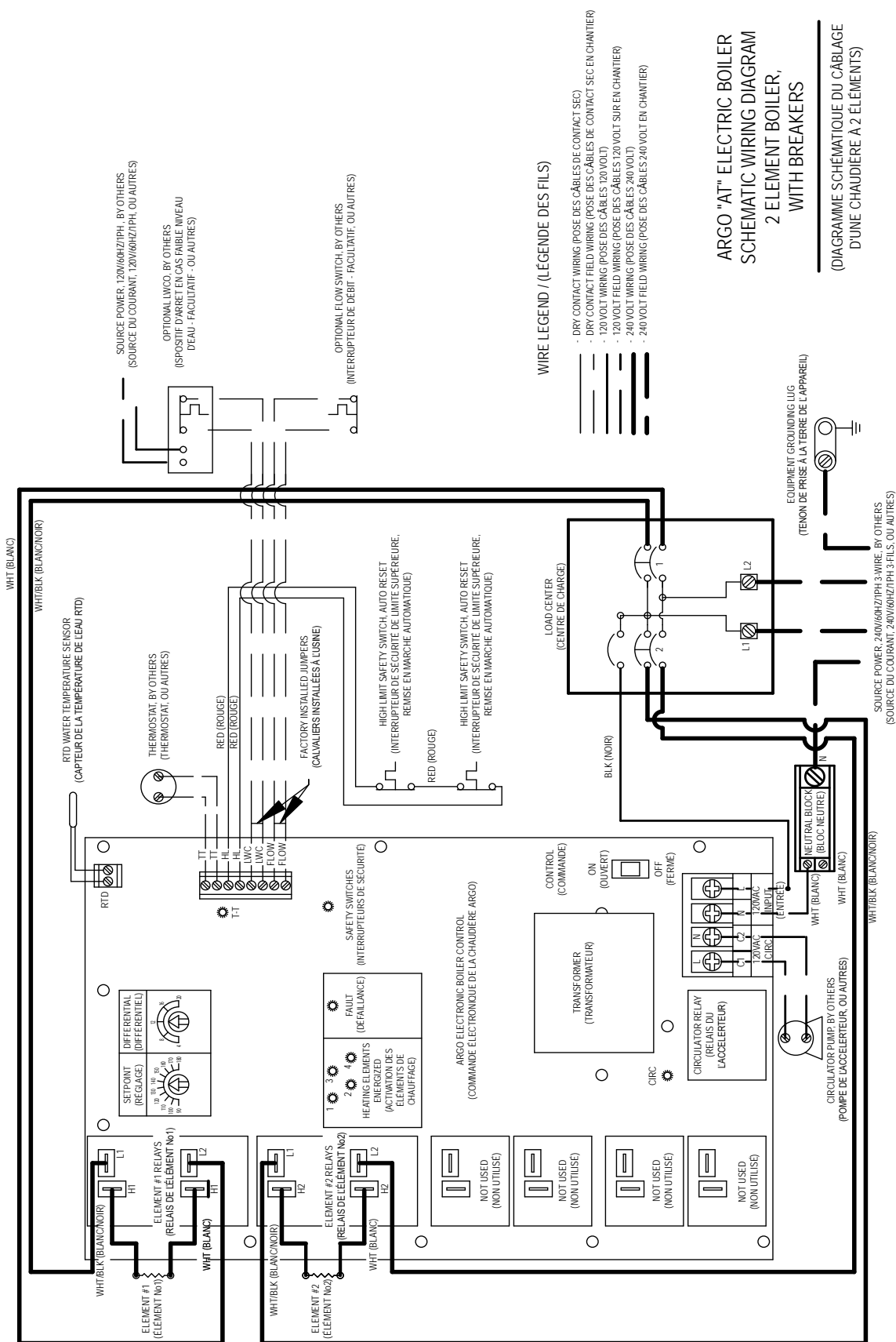

FIGURE 7B



WIRING DIAGRAMS

FIGURE 8A

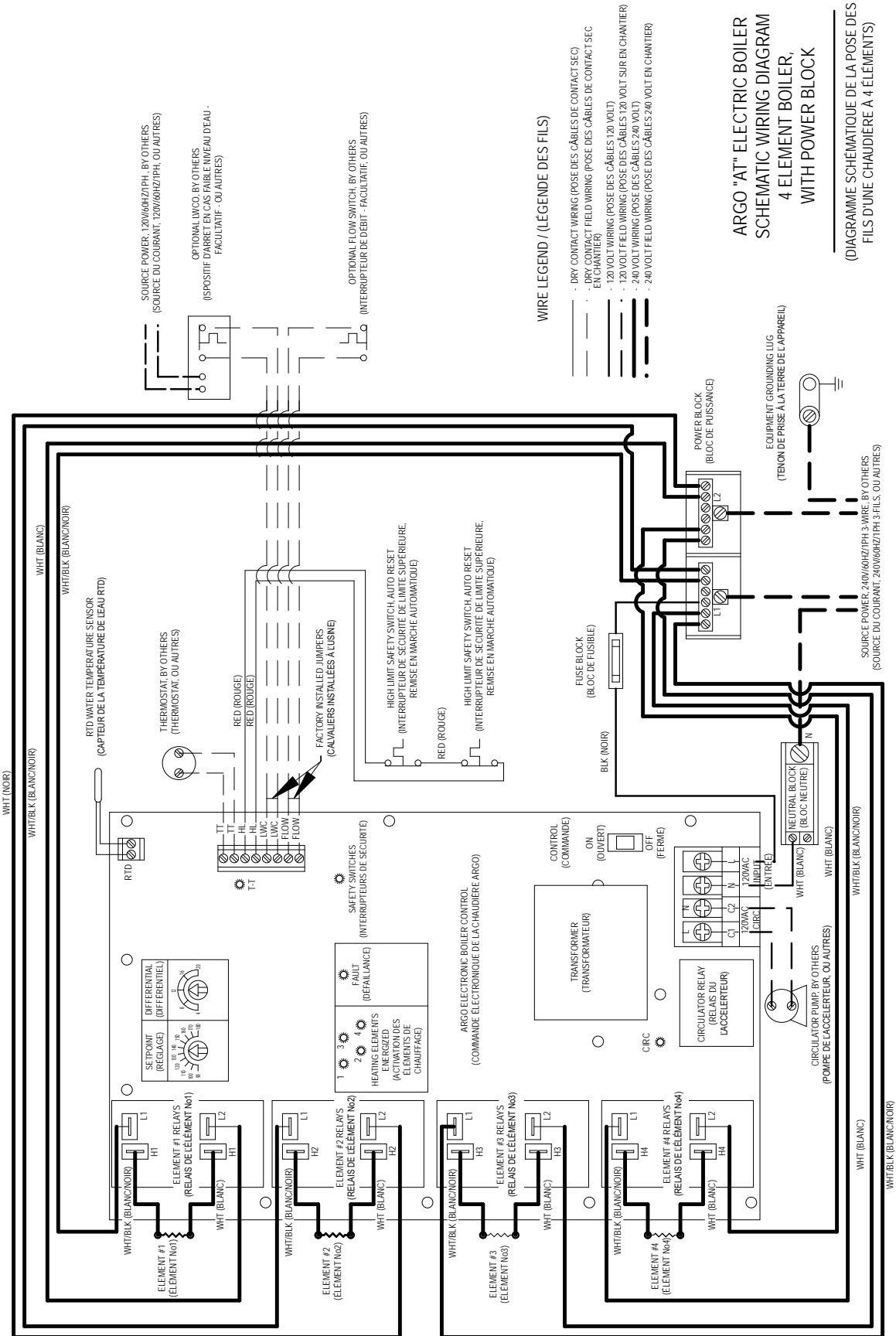
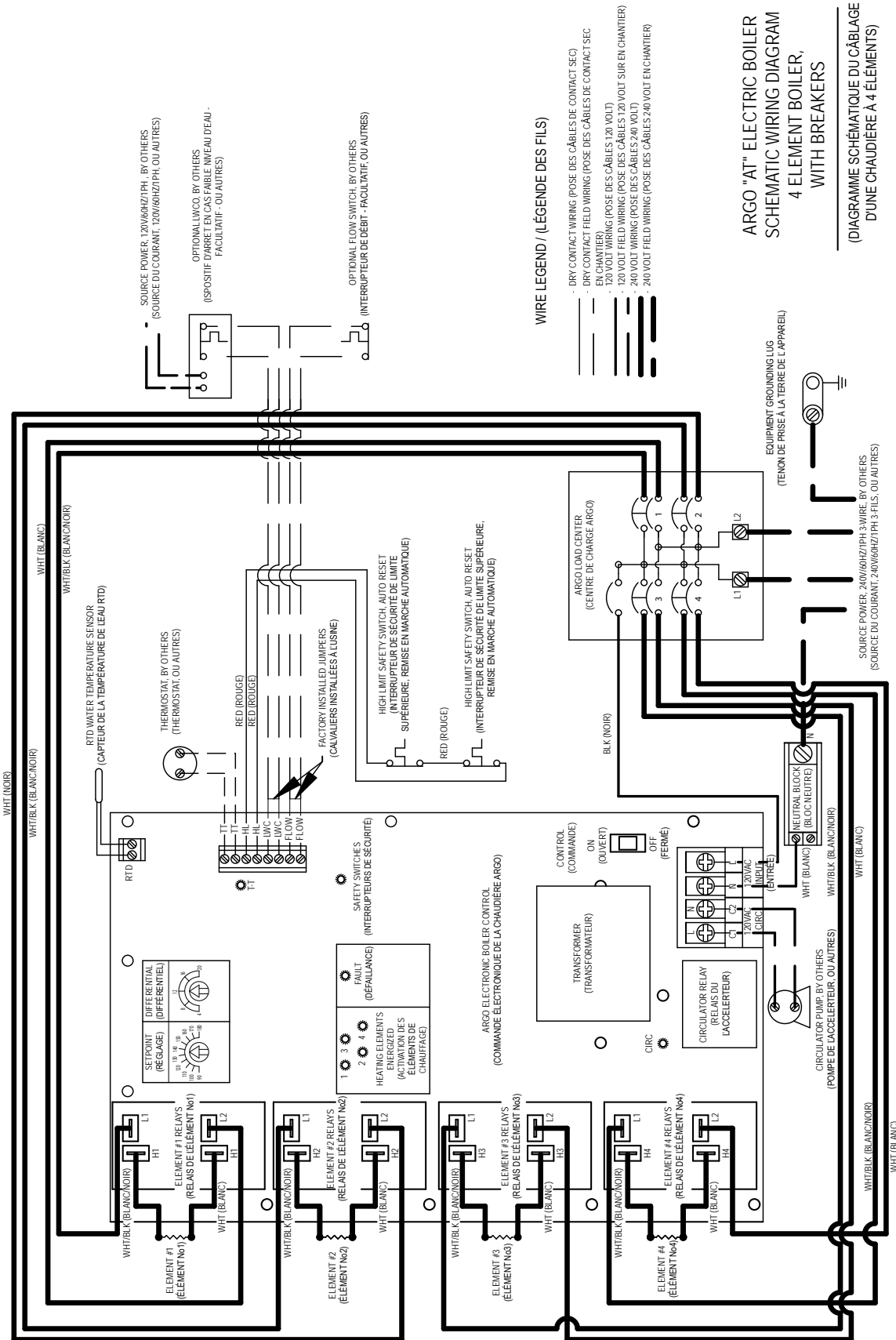
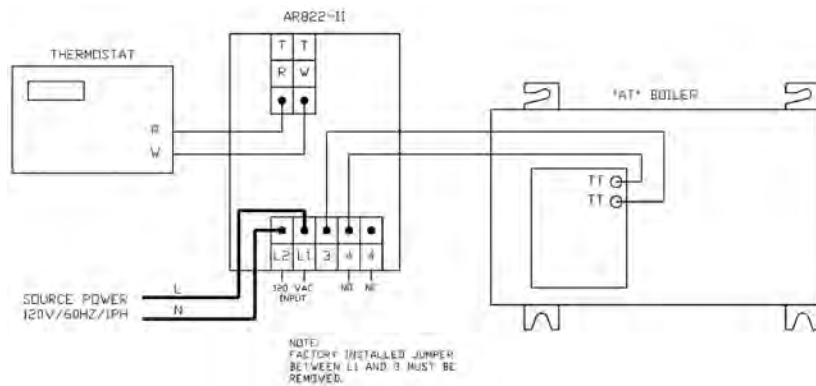

FIGURE 8B



THERMOSTAT INSTALLATION

1. Install thermostat on inside wall five feet above floor.
2. NEVER install thermostat on outside wall.
3. Do not install thermostat where it will be affected by sunlight, drafts, televisions, lighting fixtures, hot or cold pipes, fireplaces, or chimneys.
4. Instructions for final adjustment of thermostat (adjusting heating anticipator, calibration, etc.) are packaged with thermostat. **Recommended setting for heating anticipator is 0.1 amps.**



NOTE: Your Argo AT Boiler will work with standard and programmable setback thermostats.

Some programmable thermostats may cause boiler control T-T LED to flicker on and off when there is no call for heat, your thermostat will require an external 24V power supply (transformer) and isolation relay or Argo AR822 control.

STARTUP AND SEASONAL MAINTENANCE

Use qualified service agency for annual inspection of boiler and heating system.

CAUTION



Label all wires prior to disconnection when servicing controls. Wiring errors can cause improper and dangerous operation. Verify proper operation after service.

Hydronic block is now ready to be put into service.

1. Verify hydronic block circuit breaker or switch at service entrance and, depending on option, hydronic block circuit breakers within unit are in "Off" position.

NOTICE

Only propylene glycol can be used in heating system to prevent freezing. Recommendation is maximum 40% or less propylene glycol mixture to ensure proper operation of electric boiler.

2. Fill heating system with water until pressure is 10-15 PSIG. Check for leaks, repair if necessary, purge all air from system.

NOTICE

Failure to vent and keep air out of heating system will result in damage to heating elements in hydronic block. Damage of this type is not covered by manufacturer's warranty.

3. Set boiler operating temperature to designed heating water temperature by adjusting potentiometer dial located on top center of controller (Figure 4). Adjust arrow on temperature adjustment dial to water temperature required.

NOTICE

Boiler is equipped with high-limit temperature device set at 200° F as safety limit control. High limit temperature device has automatic reset function will reset at 170° F.

4. Turn on hydronic block circuit breaker at service entrance and/or disconnect switch, depending on option, and 15 amp circuit breaker on hydronic block.
5. Set one thermostat above room temperature. Circulator pump will now operate.
6. Check system again for leaks. Allow circulator pump to run until all air has been vented from system. Gurgling or rushing sound indicates presence of air.
7. Hydronic block will start to produce heat. Listen for air passing through system as water temperature increases. Water pressure will rise somewhat as temperature increases - this is normal as long as the pressure remains less than 25 PSIG.

THERMOSTAT INSTALLATION

8. When thermostat calls for heat, circulator will be energized and indicator LED will light. Heating elements are energized with element indicator LEDs. Once boiler water temperature reaches set point on temperature adjustment dial, controller will regulate boiler by staging its elements. Number of elements which stay on is based on heating demand and set point of boiler water temperature. After all room thermostats are satisfied with heat, controller de-energizes elements one after another, and switches pump off after 3 minutes.

TROUBLESHOOTING

This section is to assist service technician when trouble shooting electric boiler. It is important to isolate before proceeding. Control error codes can be helpful identifying cause of problem. If you suspect wiring fault, check all external wiring and wiring connections following wiring diagram label on inside of boiler's cover. Additional wiring diagram is included with this manual.

NOISY BOILER

1. Check water pressure of boiler. Should be 15-25 PSIG.
2. Check for air within system.

WARNING



Take extreme care when boiler cover is removed. Turn "OFF" all service to boiler. "Power On" checks should be made by qualified electrician.

HEATING ELEMENT CHANGE

Heating element change, use following procedure:

1. Turn off hydronic unit circuit breaker at service entrance and/or disconnect switch.
2. Close gate valves near inlet and outlet of hydronic block.

3. Close feed line valve if using automatic fill.
4. Open drain valve and allow water to drain from boiler. Manual operation of relief valve will assist drainage by allowing air to enter.
5. Remove cabinet cover and disconnect two wires attached to effected heating element.
6. Remove four bolts securing heating element to casting pry element loose. Take note of markings on element flange to assure proper reinstallation.
7. After element has been removed, carefully clean any remaining gasket material from casting surface. Take care not to scratch or score surface.
8. Install new gasket and heating element while assuring element is correctly positioned.
9. Close relief valve. Open feed line valve and check for leaks. Open gate valves. Install heating element wires and cabinet cover.
10. Refer to "Startup and Seasonal Maintenance" for proper purging of air prior to energizing heating elements.

Problem	Cause	Solution
No heat when called by thermostat and "TT" LED is NOT lit	Thermostat	Disconnect thermostat from control, momentarily place a jumper across terminal "TT" & "TT." If circulator starts, trouble is in thermostat.
	No power to board	Confirm control's On/Off switch is in "ON" position, check 15A circuit breaker or fuse.
"Circ" LED is NOT lit when thermostat is calling	Safety fault	Check for open contact on safety's. Confirm continuity across terminals.
	No power to board	Confirm control's On/Off switch is in "ON" position
"Safety Switch" LED is NOT lit when thermostat is calling	Safety fault	Check for open contact on safety's. Confirm continuity across terminals.
	No power to board	Confirm control's On/Off switch is in "ON" position.
"FAULT" LED is flashing	Safety fault	Refer to "Fault" codes

Hydronic block requires only minimum of periodic maintenance. Preventive maintenance tasks described below are not difficult and when done annually, will aid unit to continue its trouble free operation.

CAUTION



Turn off main power switch to block at main service entrance before any work requiring removal of cover is done for safety. All work shall be performed by qualified service personnel familiar with unit's control system operation.

1. Boiler is designed to provide years of trouble free performance under normal operating conditions. Owner should conduct general external examination at beginning of each heating season and at mid-heating seating season to assure good working performance continues. A qualified service technician should examine at least once every year.
2. Do not store anything against boiler or allow dirt or debris to accumulate in area immediately surrounding boiler.
3. Elements will burn out if not filled with water when electrical power is turned on. Do not connect thermostat wire until system has been filled with water. Drain water out of system only when absolutely necessary to make repairs or prevent freeze-up during extended cold weather shutdown.
4. Temperature and pressure gauge should be checked frequently. During normal operating conditions, pressure should be stable throughout heating season. If pressure under normal operating conditions consistently rises and falls over period of time, this can indicate fill valve leak, system leak, or compression tank malfunction. Leaks anywhere must be repaired without delay. If leaks or significant pressure fluctuations are observed, call for service immediately.
5. Check pressure relief discharge piping to assure discharged water will be properly routed to suitable container or drain. Manually operate pressure relief valve by pulling lever at end of valve until lever is in line with center-line of valve. (Figure 9) Close valve to avoid losing excessive amount of water. Repeat this procedure several times on quick cycling basis to release any sediment that could block relief valve pressure sensing mechanism. On heating system using manual water make-up or feed mechanism, do not to allow system pressure to drop to 0 PSI when cycling relief valve. Allowing condition to occur could cause air to enter system requiring purging as described in "Startup and Seasonal Maintenance" on page 15.

FIGURE 9

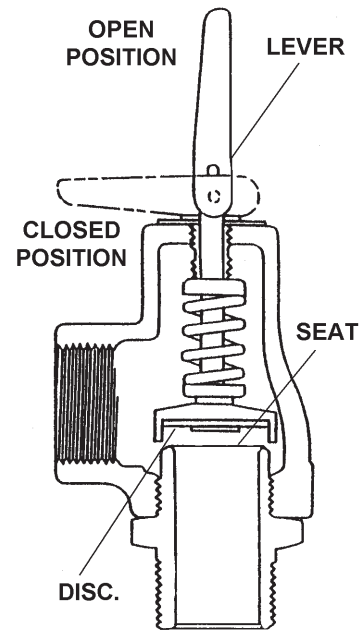

If relief valve fails to close completely after cycling, remove it for cleaning or replacement. Turn off power to boiler and isolate hydronic block by shutting off inlet and outlet gate valves. Reduce water pressure to zero by opening relief valve. Remove relief valve and inspect valve disc and seat. Cleaning parts with clean lint free cloth may be all that is necessary. If this procedure fails replace valve with new one of equal pressure and discharge rating. After installing cleaned or new relief valve, open gate valves and follow procedure described in "Startup and Seasonal Maintenance" on page 15.

6. Inspect and check field entrance wire connections to unit for any signs of looseness or over heating. Verify wire lugs are tight and torqued to manufacture recommended settings - see Table B.

PARTS LIST - 2 ELEMENT ELECTRIC BOILERS

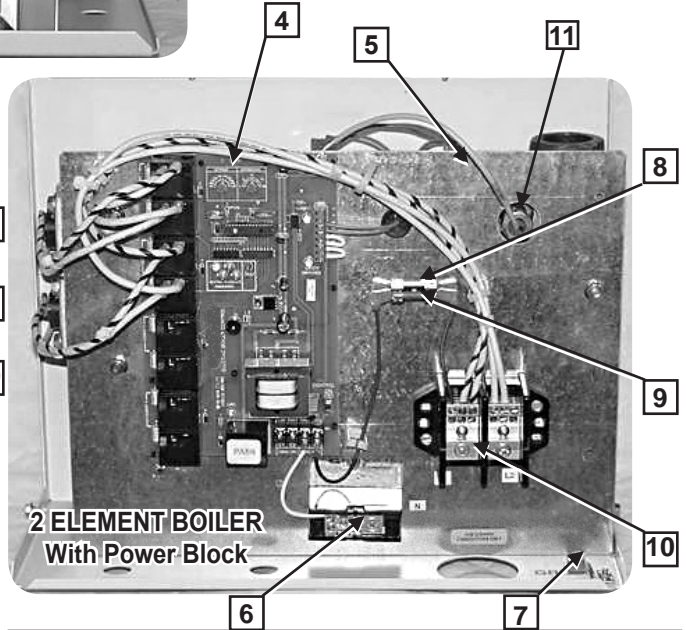
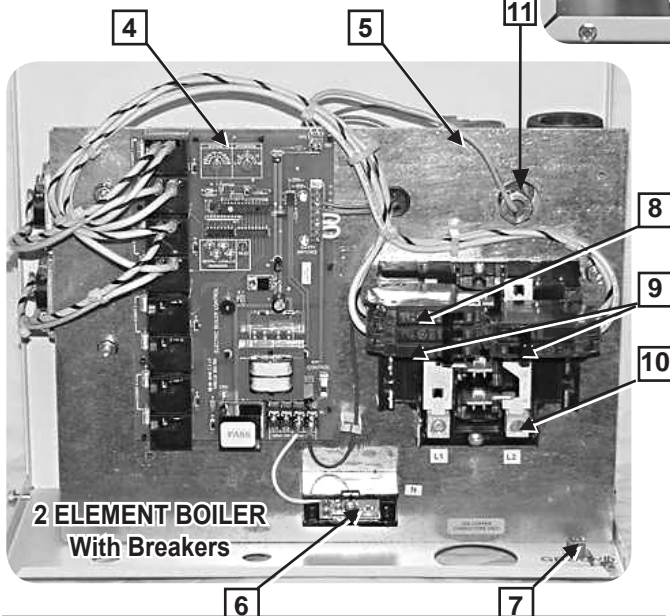
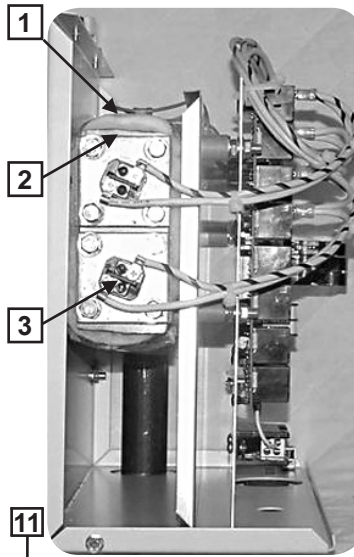

2 Element Electric Boiler w/Breakers		
Item	Part Number	Description
1	S47	Safety Limit Control (High Limit - Fixed Temp)
2	G12	Gasket - Heating Element
3	E13	Heating Element - 3 KW/240 Volt
	E14	Heating Element - 4 KW/240 Volt
	E15	Heating Element - 5 KW/240 Volt
	E16	Heating Element - 6 KW/240 Volt
4	Z3002	Control Board - 2 Element Boiler
5	240004757	RTD Sensor
6	B194	Neutral Terminal Block
7	L9	Ground Connection Lug
8	B28	Circuit Breaker 15 A - 1 Pole - G.E. THQP 115
9	B27	Circuit Breaker 40 A - 2 Pole - G.E. THQP 240
10	I25	Load Center Assembly - G.E. TLM812U2
11	240004756	Brass Well
-	V1	Relief Valve - 30 PSI
-	1260006	Temperature/Pressure Gauge
-	C57	Pressure Vessel - Cast Iron, 2 Element
-	Z302A	Control Panel Assembly, 2 Element (Complete)

2 Element Electric Boiler w/Power Block		
Item	Part Number	Description
1	S47	Safety Limit Control (High Limit - Fixed Temp)
2	G12	Gasket - Heating Element
3	E13	Heating Element - 3 KW/240 Volt
	E14	Heating Element - 4 KW/240 Volt
	E15	Heating Element - 5 KW/240 Volt
	E16	Heating Element - 6 KW/240 Volt
4	Z3002	Control Board - 2 Element Boiler
5	240004757	RTD Sensor
6	B194	Neutral Terminal Block
7	L9	Ground Connection Lug
8	F3	Fuse Block, 1/4" x 1-1/4" Fuse, 300V
9	F4	Fuse, 10amp, Ceramic, ABC-10
10	P8	Power Distribution Block
11	240004756	Brass Well
-	V1	Relief Valve - 30 PSI
-	1260006	Temperature/Pressure Gauge
-	C57	Pressure Vessel - Cast Iron, 2 Element
-	Z313	Control Panel Assembly, 2 Element (Complete)

PARTS LIST - 4 ELEMENT ELECTRIC BOILERS

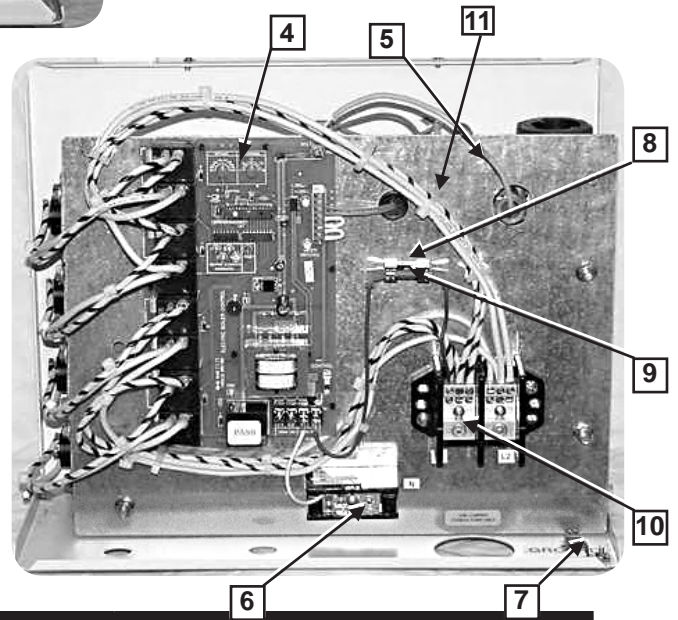
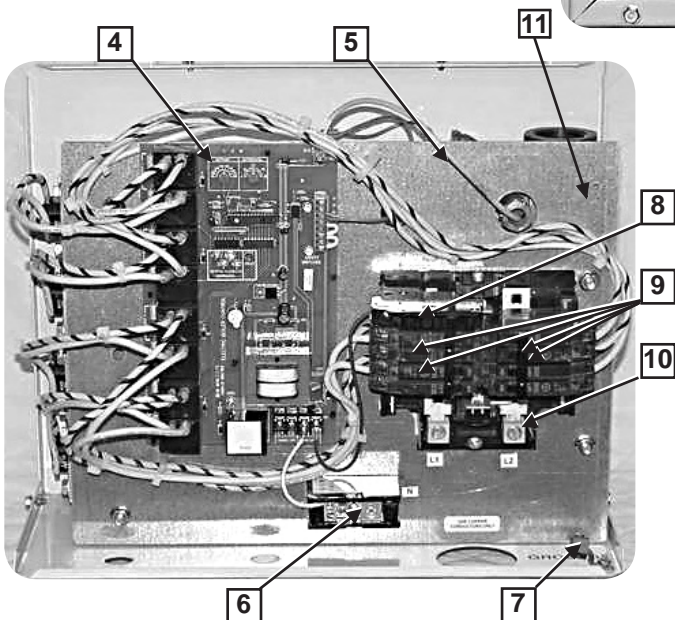
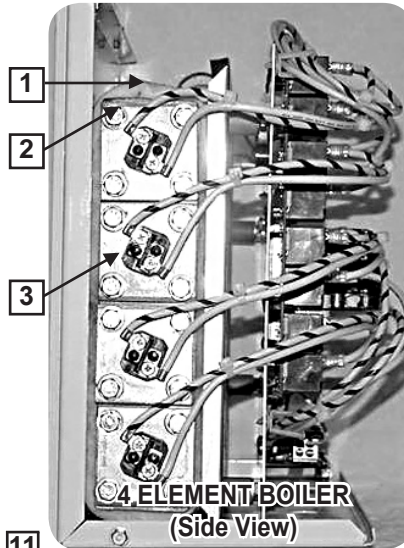

4 Element Electric Boiler w/Breakers		
Item	Part Number	Description
1	S47	Safety Limit Control (<i>High Limit - Fixed Temp</i>)
2	G12	Gasket - Heating Element
3	E13	Heating Element - 3 KW/240 Volt
	E14	Heating Element - 4 KW/240 Volt
	E15	Heating Element - 5 KW/240 Volt
	E16	Heating Element - 6 KW/240 Volt
4	Z300	Control Board - 4 Element Boiler
5	240004757	RTD Sensor
6	B194	Neutral Terminal Block
7	L9	Ground Connection Lug
8	B28	Circuit Breaker 15 A - 1 Pole - G.E. THQP 115
9	B27	Circuit Breaker 40 A - 2 Pole - G.E. THQP 240
10	I25	Load Center Assembly - G. E. TLM812U2
11	240004765	Brass Well
-	V1	Relief Valve - 30 P.S.I.
-	1260006	Pressure/Temperature Gauge
-	C32	Pressure Vessel - Cast Iron, 4 Element
-	Z304A	Control Panel Assembly, 4 Element (<i>Complete</i>)

4 Element Electric Boiler w/Power Block		
Item	Part Number	Description
1	S47	Safety Limit Control (<i>High Limit - Fixed Temp</i>)
2	G12	Gasket - Heating Element
3	E13	Heating Element - 3 KW/240 Volt
	E14	Heating Element - 4 KW/240 Volt
	E15	Heating Element - 5 KW/240 Volt
	E16	Heating Element - 6 KW/240 Volt
4	Z300	Control Board - 4 Element Boiler
5	240004757	RTD Sensor
6	B194	Neutral Terminal Block
7	L9	Ground Connection Lug
8	F3	Fuse Block, 1/4" x 1-1/4" Fuse, 300V
9	F4	Fuse, 10amp, Ceramic, ABC-10
10	P8	Power Distribution Block
11	240004756	Brass Well
-	V1	Relief Valve - 30 P.S.I.
-	1260006	Pressure/Temperature Gauge
-	C32	Pressure Vessel - Cast Iron, 4 Element
-	Z314	Control Panel Assembly, 4 Element (<i>Complete</i>)

ONE SINGLE ZONE

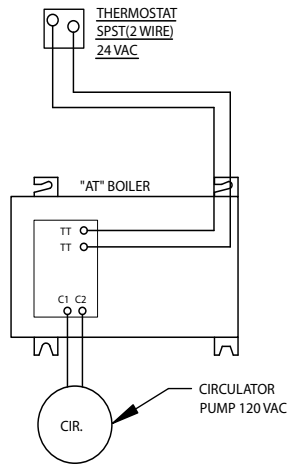

SINGLE ZONE WITH CIRCULATOR
2 BOILERS

ITEM NUMBER	DESCRIPTION
R35C	Relay 10A 24VAC
240004745	Relay Base, DIN Rail Mount
240004746	DIN Rail Approximately 2" Long

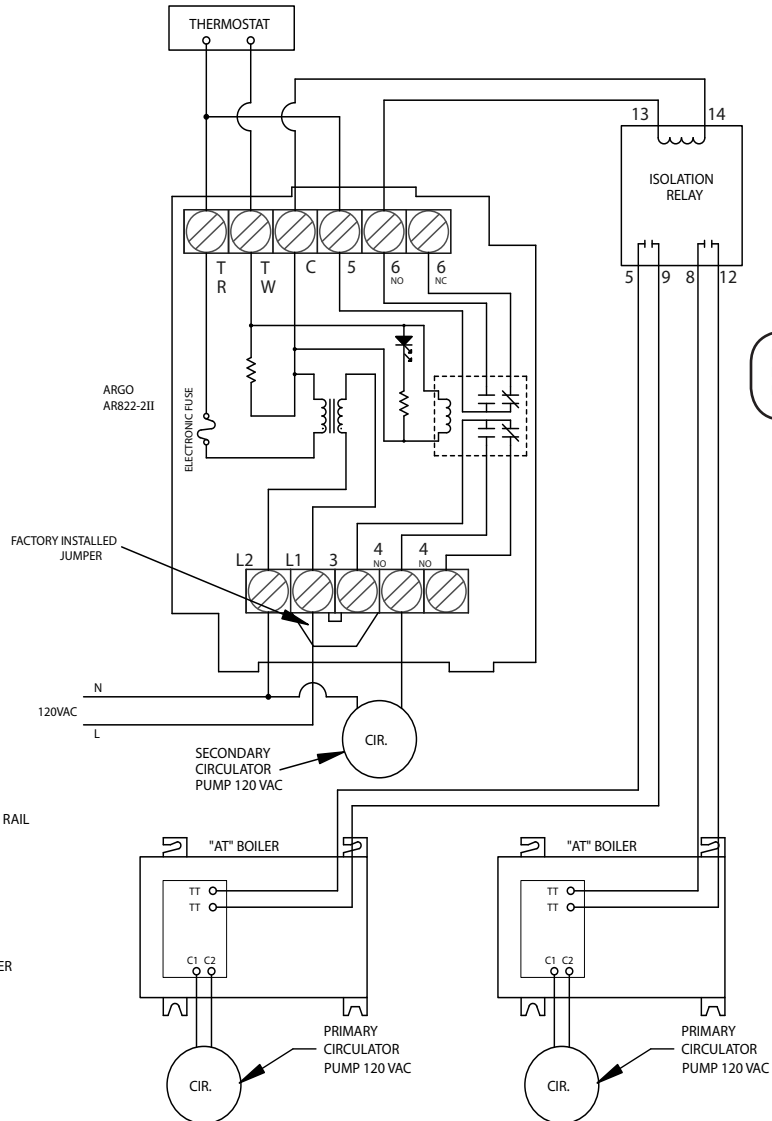

NOTE:
NUMBERS REFER TO NUMBER
DESIGNATIONS ON RELAY BASE, SEE BELOW.

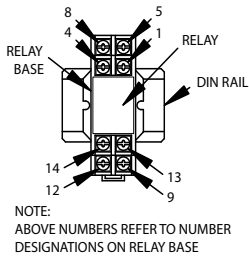

ADDITIONAL WIRING DIAGRAMS

TWO ZONES WITH CIRCULATORS 2 BOILERS

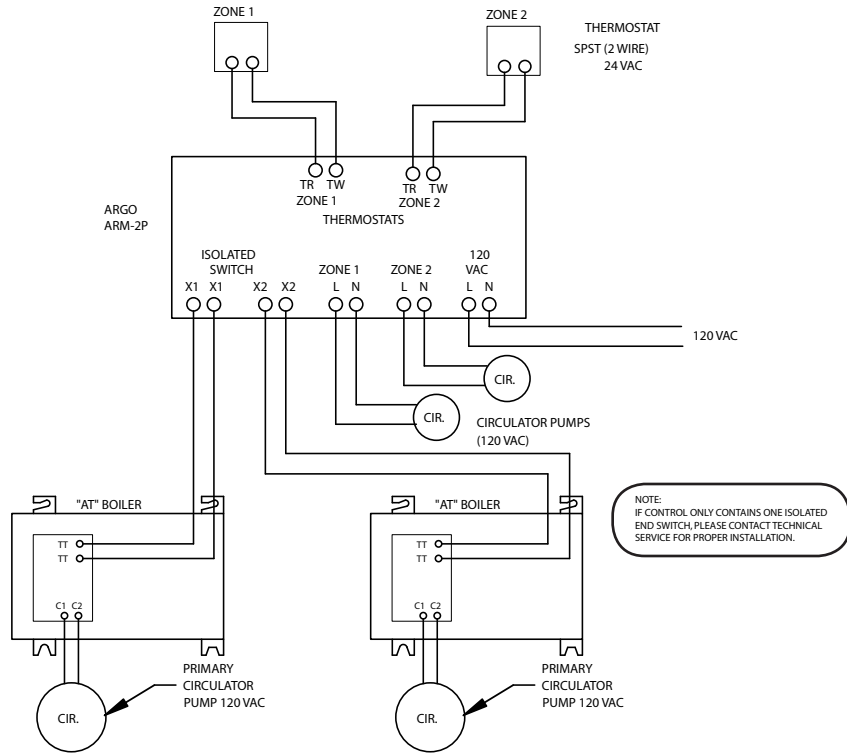

THREE ZONES WITH ZONE CONTROL VALVES 2 BOILERS

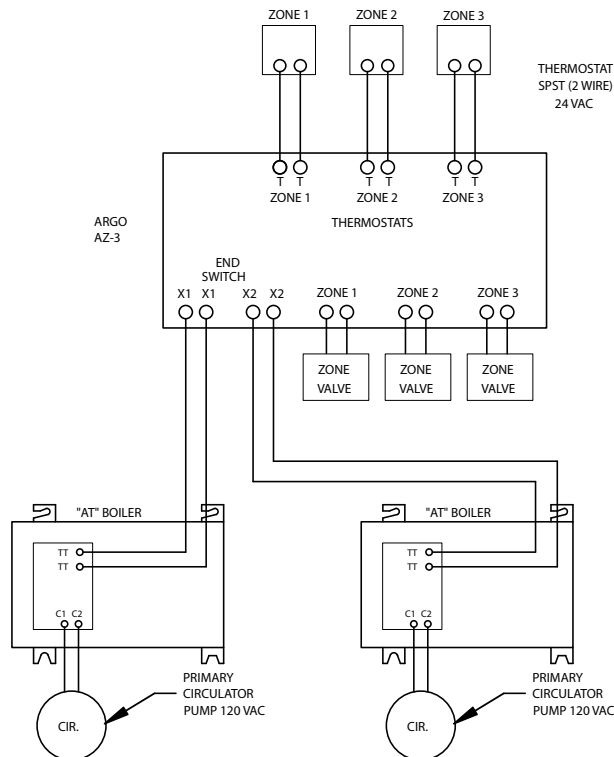

ADDITIONAL WIRING DIAGRAMS

THREE ZONES WITH CONTROL VALVES

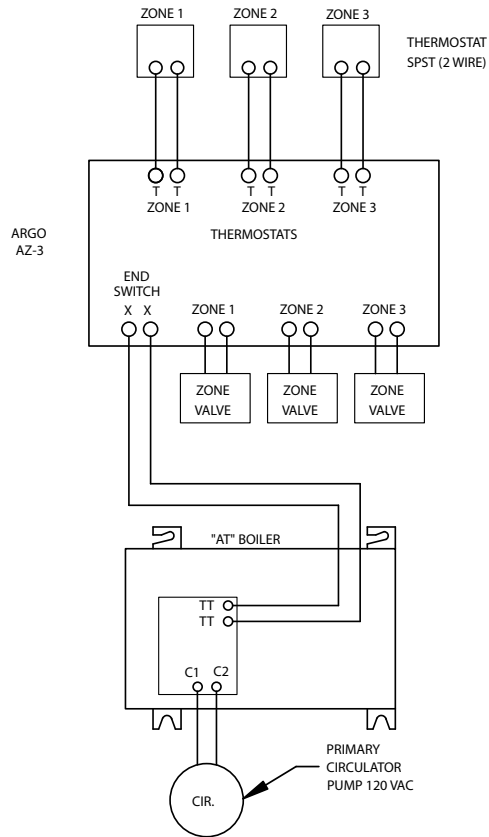

THREE ZONES WITH CIRCULATORS

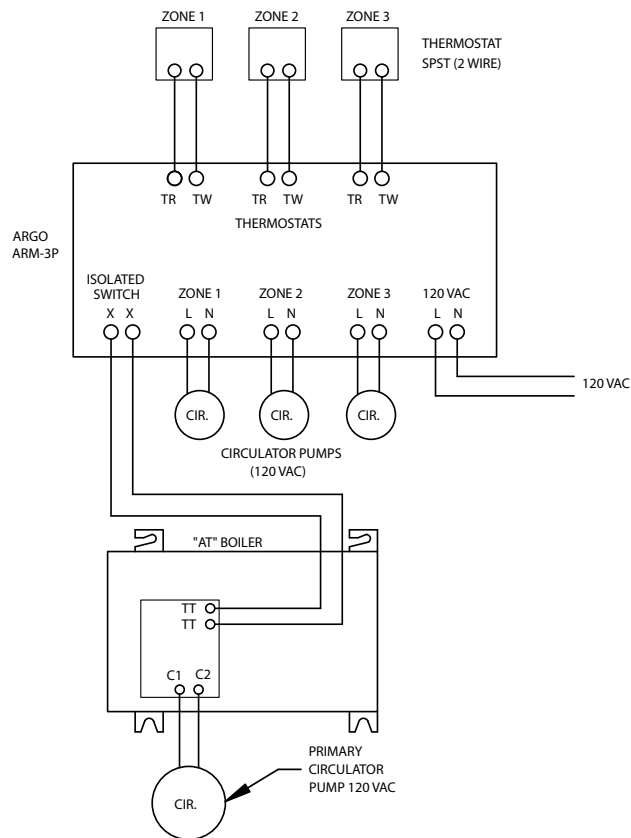

MODULAR BOILER PIPING

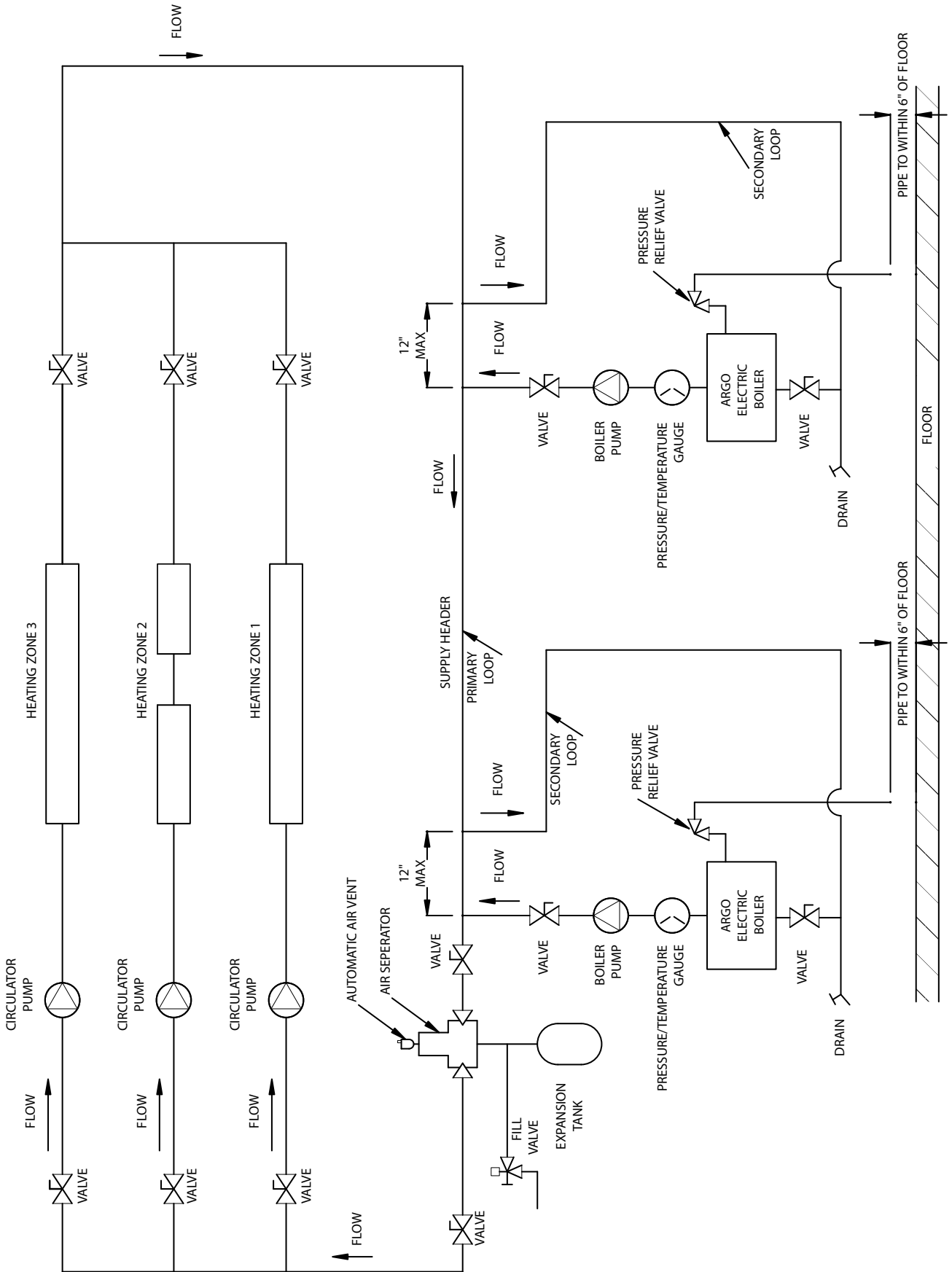

WARNING



Due to exposure to potentially dangerous voltages, troubleshooting should be performed by a qualified installer or service agency only. Failure to do so could result in property damage, personal injury, or loss of life.

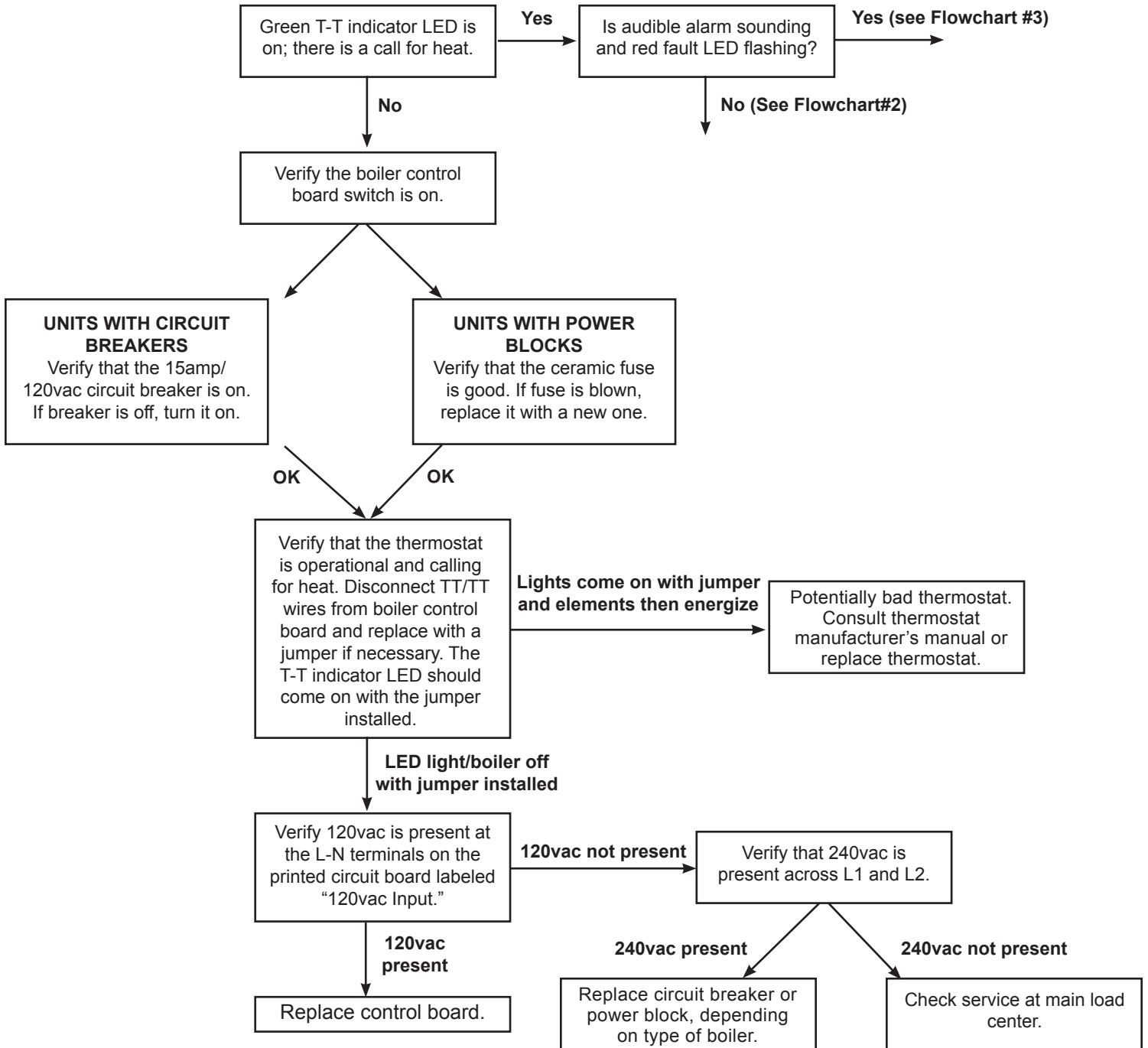

TROUBLESHOOTING - FLOWCHART#2

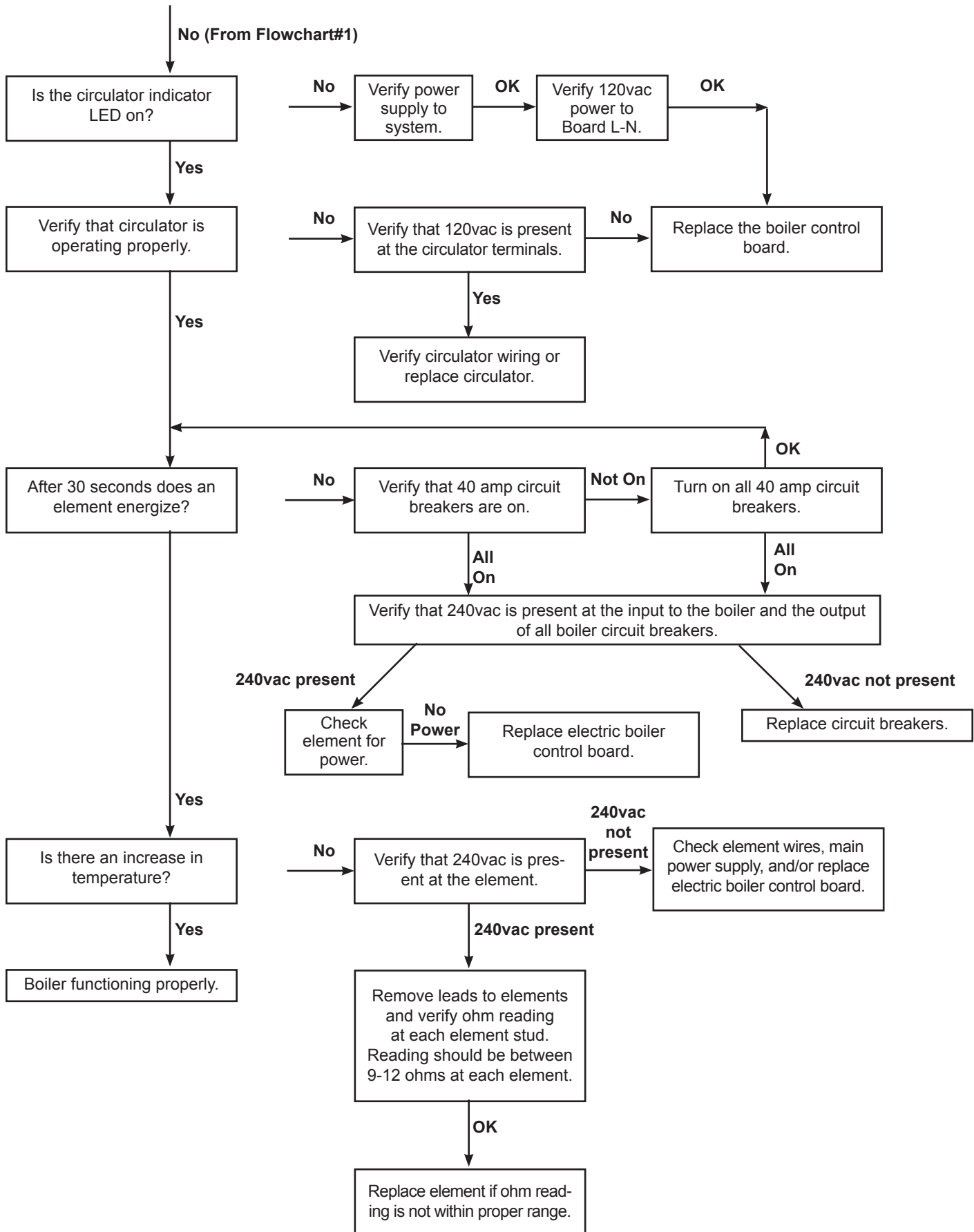

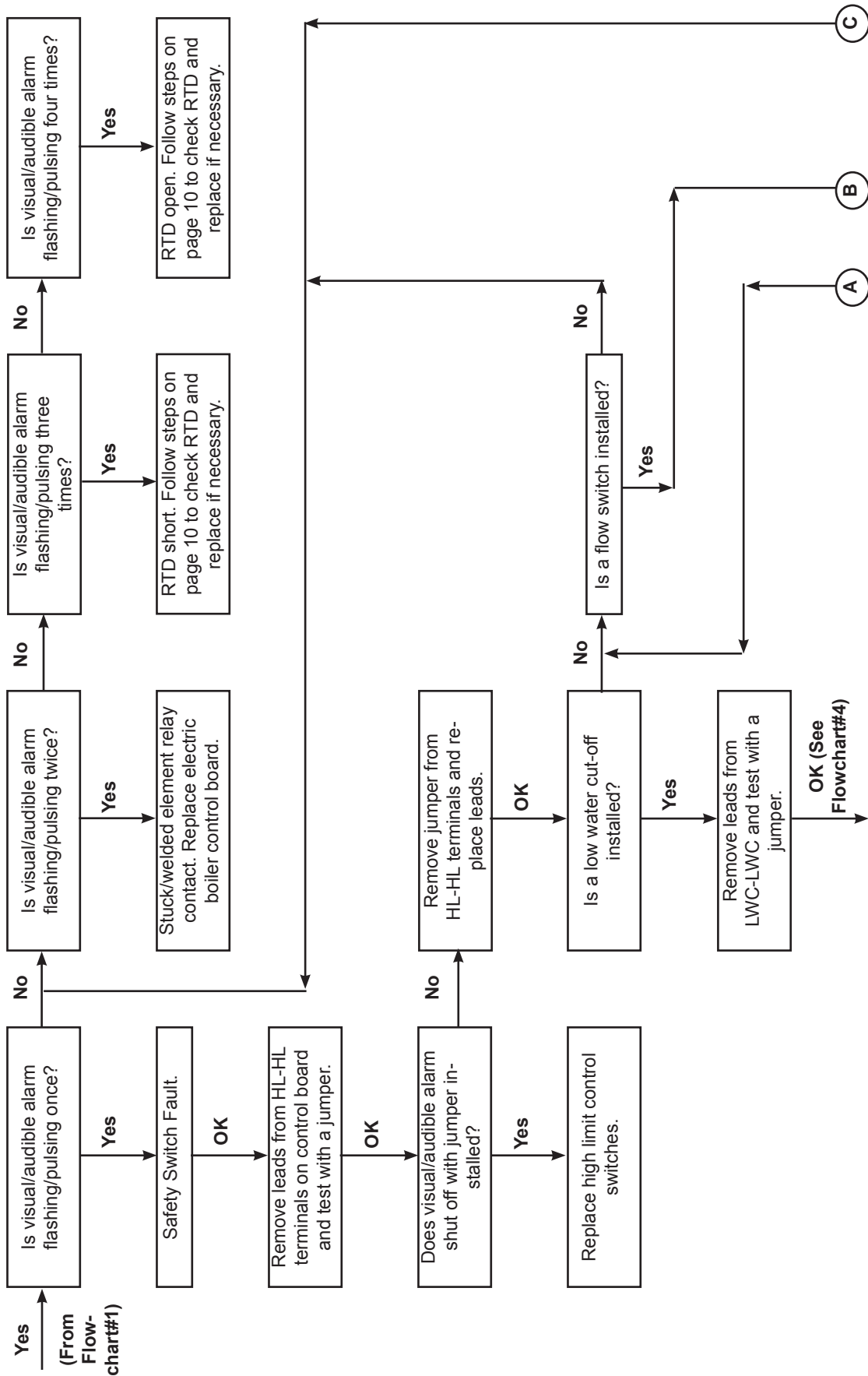

TROUBLESHOOTING - FLOWCHART#4

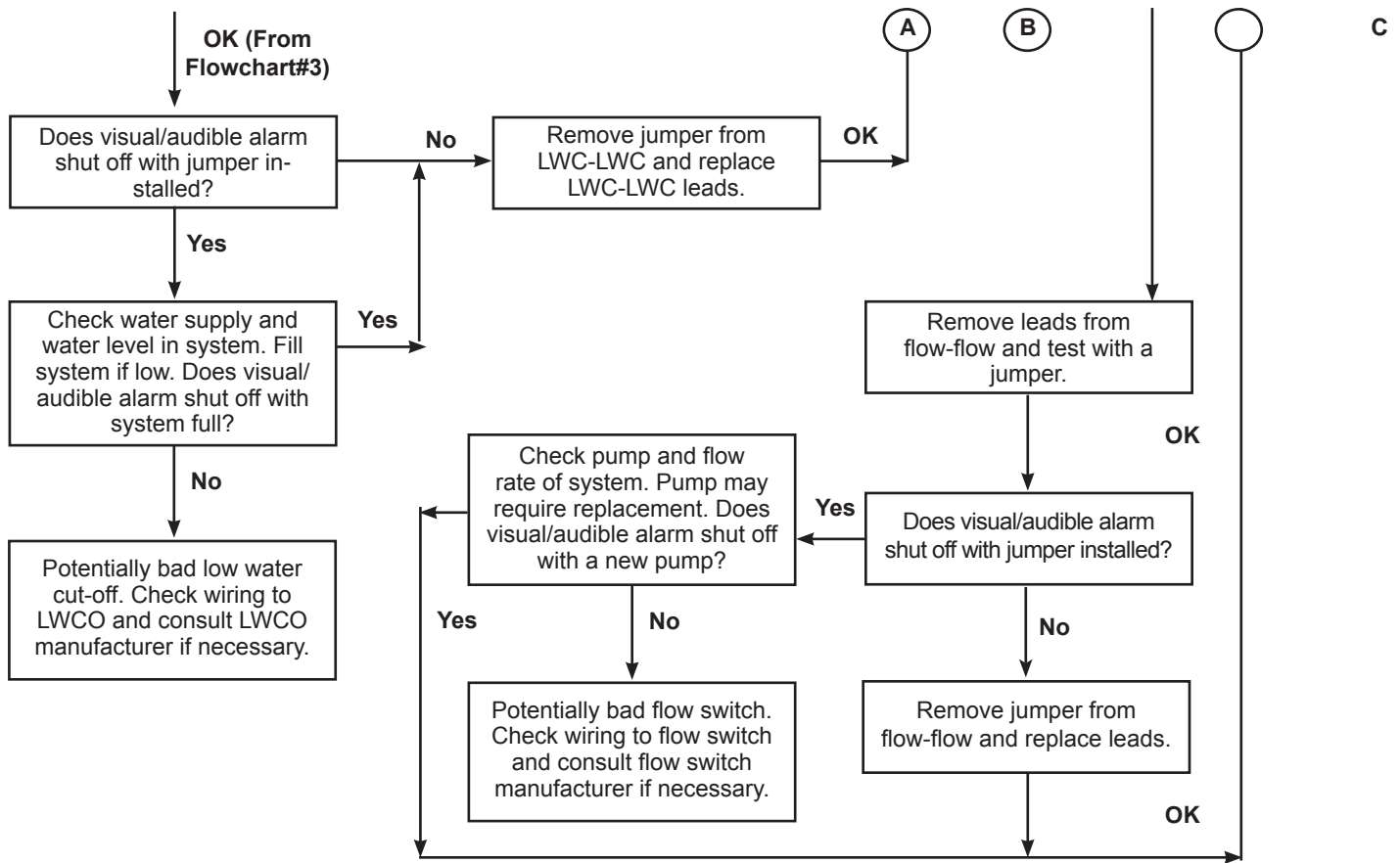

"AT" SERIES BOILER DIMENSIONS

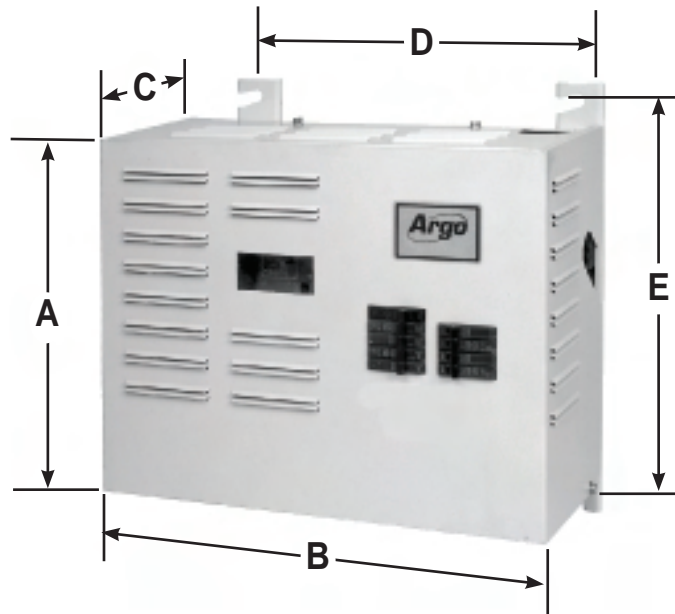

Dimensions					Inlet & Outlet Pipe Size	Approximate Shipping Wt.
A	B	C	D	E		
14-5/8"	18-5/8 "	9-1/32"	14-3/8"	16-15/32"	1-1/4" NPT	70 lbs.

Model Number: _____

Serial Number: _____

Date Installed: _____

Contractor: _____

Contact: _____

Address: _____

Telephone Number: _____

After Hours Number: _____

If different from Installation Contractor:

Service Tech: _____

Telephone Number: _____

After Hours Number: _____

ECR International Inc.
2201 Dwyer Avenue
Utica, NY 13501
www.ecrinternational.com
www.argocontrols.com

