

2-psi Gas Piping Systems...

- FLEXIBLE, HIGH PRESSURE GAS PIPE
- 325 SERIES GAS PRESSURE REGULATOR
- MANUAL GAS BALL VALVE



For your Domestic Gas Piping Needs!

The 2-psi domestic gas piping concept was first introduced nearly 40 years ago, and has become a proven cost-saving load builder for gas utilities, as well as a viable option for HVAC contractors.

The system consists of gas metered at 2-psi (or sometimes 5-psi), with tubing used instead of traditional pipe for internal household distribution. At or near appliances, gas pressure is reduced to 7" or 8" w.c. by a Maxitrol 325 Series L-model gas pressure regulator.

A BV Series manual ball valve is also available, designed especially for use with our 325 Series L-model gas pressure regulators. They offer the perfect combination for household piping needs.

A Time for Change...



Historically, gas piping systems have predominantly been 3/4" black iron or steel pipe. The development of semi-rigid copper tubing and the introduction of corrugated stainless steel (CSST) have provided HVAC contractors a way to make the transition into the field of gas piping systems. The gas piping, however, makes up only one component in the design and installation of the residential and commercial 2-psi gas piping systems. An operating pressure change is the heart of the new *system* concept.



The entire 2-psi concept would not have been possible without the development of the compact, low-cost Maxitrol pounds-to-inches regulators. These regulators reduce inlet pressure as high as 5-psi down to appliance use levels.

To deliver positive dead-end lockup, the 325 Series L-model regulators feature a high leverage valve linkage assembly. They are capable of precise regulating control from full flow down to pilot flows. When combined with Maxitrol's vent limiting devices, labor and material costs are reduced by eliminating vent lines to the outdoors.



The third component of the 2-psi gas piping system is Maxitrol's manual gas ball valve, which is designed for quick, quarter-turn operation. The 325 Series L-model gas pressure regulators are CSA certified for 2-psi and 5-psi (see line standard, page 3) system applications. Our manual ball valves are certified as well.

Acceptance continues to grow at an accelerated rate, as more utilities put the 2-psi concept to work. The 2-psi system is now being utilized worldwide on new construction and LP conversions.

A copyrighted publication of

Elevated Pressure Piping Systems

- **Stimulates New Markets:** LP conversions, business, multifamily dwellings, new custom and project homes. Generally, 2-psi for residential applications and 5-psi for some commercial applications.
- **Reduces Installation Cost:** Cheaper to pipe than conventional low pressure system.
- **Greater Protection:** Less gas leakage from 3/8" diameter tubing — semi-rigid piping systems also contain less fittings.

LP GAS CONVERSION

Many gas utilities are using the 2-psi system for franchise extension into areas previously served by LPG. There is significant installation savings when the existing 3/8" OD copper tubing already in the homes is utilized. Since the new meter set may be some distance from the old LP tubing, a tie line is sometimes required, and this is often 1/2" tubing. One or more Maxitrol fuel line regulators are installed downstream at the appliance take-off points, so that no more than 1" w.c. drop is experienced from the outlet of the Maxitrol regulator to the entrance of the appliance manifold.

HIGH RISE APARTMENTS

High rise apartment buildings now offer great new load building capability to gas utilities, as well. Copper tubing has been used to deliver 2-psi service to high rise installations with significant savings over conventional high rise installations.

NEW HOMES AND SUBDIVISIONS

In addition, the "all gas" neighborhood makes a lot of sense to utilities, builders and home buyers when it's implemented with the 2-psi system. Utilities can offer project and custom builders a more attractive "package", not only in cost, but in appearance and safety. The small tubing running from meter to appliances definitely "clean-up" the basement, and pose no more placement or installation problems than electrical cable.

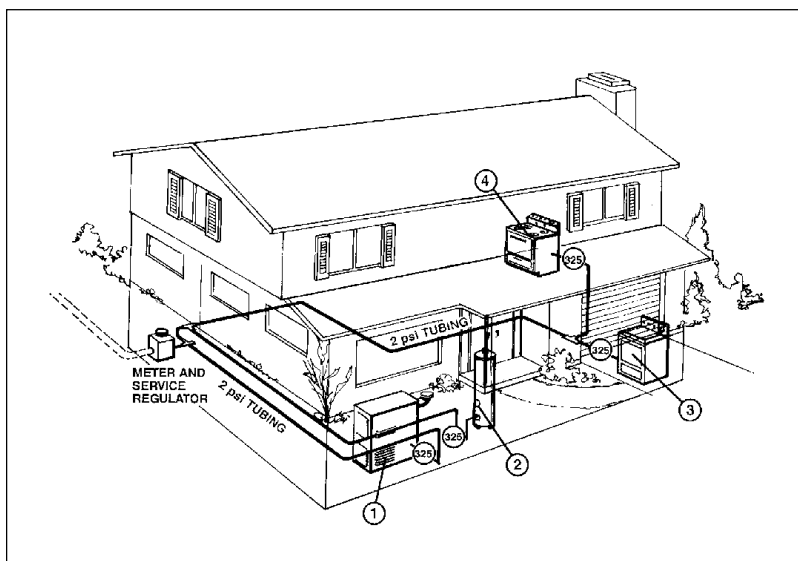

Definitely an Improved System...

Participating utilities have found less complaint call backs with 2-psi than with a 6" w.c. system.

Less Escapement Volume: Gas at 6" w.c. escapes from a 3/4" pipe at about three times the rate of gas from a 3/8" OD tube at 2-psi. The chart below shows flow comparisons at the discharge end. From the standpoint of uncontrolled escape of gas within a building, the 2-psi system has less flow than the 6" w.c. system.

FLOW FROM OPEN PIPE
CFH of Natural Gas - 1000 btu./cu. ft.

Less Escape Volume	Length of Service		
	25 ft.	50 ft.	100 ft.
3/4" iron pipe at 6" w.c.	600	440	315
3/8" OD tubing at 2-psi	210	148	105

Less Leakage Complaints: Statistics to date indicate less leakage complaints from the 2-psi system than from the 6" w.c. system. One utility reported no complaint call backs within one year in a high rise apartment involving 274 units.

Lock-up Characteristics: The 325 Series L-model regulator is excellent for controlling the full range of flow rates from main burner loads down to pilot loads. The lever acting 325 Series regulator possesses excellent lock-up characteristics.

Vent Limiting (325-3L & 325-5AL only): Maxitrol offers optional vent limiting devices which eliminate the need to run vent piping to an outside area. In the event of a diaphragm rupture, gas escapement is limited to within ANSI standard level.

Fitting Practices Proved: Both flared fittings and silver soldered fittings have been used without event on the 2-psi system. There are fewer joints in the 2-psi system than in the 6" w.c. system.

No Nailing Problems: At the outset of the 2-psi system, some feared nails would be inadvertently driven into the tubing. However, experience has shown that nails could not be driven into tubing that was loose between joists or studs. At points where tubing is to be firmly fixed against wood so that it is in a rigid state, manufacturers typically offer a variety of shielding accessories.

Typical 2-psi house piping system using Maxitrol 325 Series gas pressure regulators — Use one with each appliance:

1. Gas Furnace
2. Gas Water Heater
3. Gas Dryer
4. Gas Range

The New Line Pressure Regulator Standard - ANSI Z21.80

Although Maxitrol's 325 Series are certified (ANSI Z21.18) as *appliance* regulators (see bulletin MS2055), in the past they have often been used as *line* pressure regulators. There is now also a new standard for line regulator applications.

Z21.80 is the ANSI standard for line pressure regulators, intended for application in natural gas piping systems and LP (propane). Maxitrol's 325 Series L-models are CSA certified (Z21.80) for 2-psi inlet pressure, with the 7 to 11 (inches w.c. outlet) spring.



The L-models are Class 1, pounds to inches line regulators, meeting utility specifications, for use on 2-psi piping systems. The regulators are a high performance type - reducing pounds pressure to a level within the appliance's operating supply range.

The line regulator is located upstream of equipment already fitted with an appliance regulator.

The 325 Series L-model regulators feature a lever actuated valve, and lockup pressure can vary with the speed of the solenoid valve and its location.

The self-aligning valve is made of nitrile rubber. Housings are durable aluminum die castings and all internal parts are carefully selected and corrosion resistant. The diaphragms are of high quality supported synthetic rubber compounds.

The regulator is certified for inlet pressures up to 2-psi. Over-pressure protection is not required for supply pressures up to 2-psi. The regulator itself provides no downstream over-pressure protection in the event of failure.

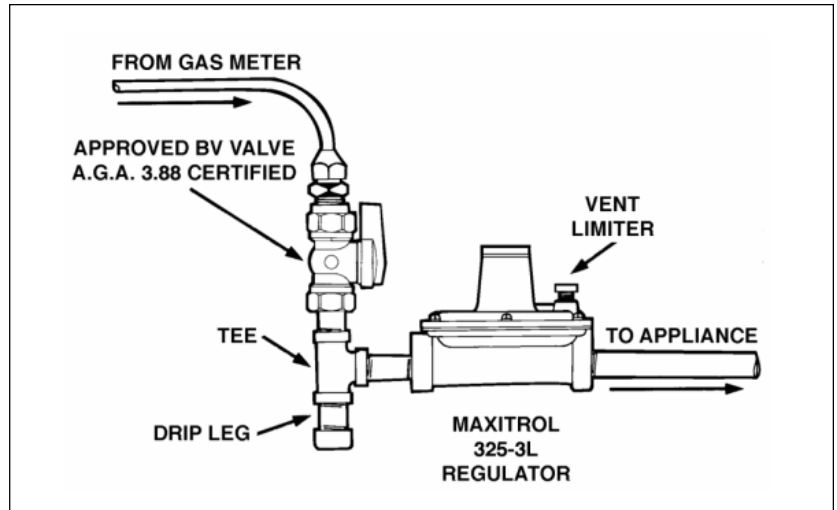

At supply pressures above 2-psi, the new standard requires the use of an over-pressure protection device (OPD) for use with the regulator. (See below.)

Other 325 Series regulators will continue to be available as CSA certified appliance regulators, as well as non-certified models for up to 10-psi inlet pressure (see bulletin MS2055).

Positioning for Best Performance

The 325 Series is suitable for multi-poise mounting. But when using the vent limiting device, the regulator must be mounted in a horizontal upright position. Vent limiters are designed for use indoors and spaces where limiting the amount of gas escapement due to diaphragm failure is critical. Vent limiters should not be used outdoors if they are exposed to the environment.

325 Series Line Pressure Regulators & OPDs for 2 to 5-psi Installations

The ANSI Z21.80 Standard for Line Pressure Regulators, installations exceeding 2-psi (up to 5-psi) nominal require a tested and approved over-pressure protection device (OPD). The OPD limits downstream pressure to 2-psi maximum in the event of line regulator failure.

Maxitrol's 325 Series Line Pressure Regulators with OPDs are CSA certified (Z21.80) for up to 5-psi inlet pressure. Maxitrol built OPDs are approved and tested with the regulator. The companion OPD provides the required downstream protection.

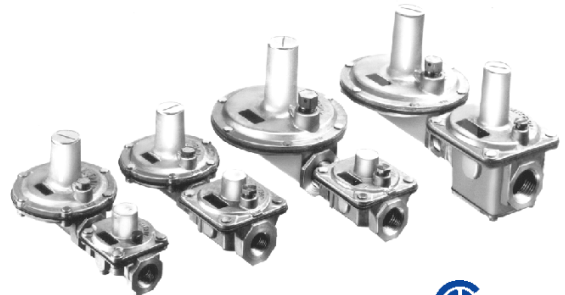

Available models include: 325-3L47, 325-3L48, 325-5AL48, 325-5AL600. Consult Maxitrol Company.

Flexible, High Pressure Gas Pipe

Available from a variety of piping manufacturers, semi-rigid copper tubing and corrugated stainless steel (CSST) offer several advantages over black iron pipe:

FEATURES:

- Polyethylene coated or uncoated flexible piping
- Easy-to-identify line markings
- Faster, easier installations
- Ideal for new construction or retrofit applications



(Not available from Maxitrol)

Manual Gas Ball Valve

Ball valves from Maxitrol have a strong body of forged brass, female NPT inlet and outlet, hard chrome plated ball, and anticorrosion Dacromet treated handle.

FEATURES:

- CSA certified (Z21.15 and 3.88)
- 1/4", 3/8", 1/2", 3/4", 1", 1 1/4", 1 1/2", 2", 2 1/2", 3" NPT



Vent Protector

Designed for outdoor applications. Use on vent opening to protect breather hole from rain, snow, dust or other foreign particles and insects.

FEATURES:

- For use in 325-3 and 325-3L.
- For 1/8" NPT vent

Note: Not a vent limiting device.

Vent protector must be mounted in an upright position.



Vent Limiting Means

Optional automatic vent limiting device - ball check permits free inhalation for fast regulator-diaphragm response on opening cycle, but limits gas escapement to within ANSI standards, should a diaphragm rupture.

FEATURES:

- CSA certified for use with 325-3L and 325-5AL
- European approval
- 1/8" NPT for 325-3L, 3/8" NPT for 325-5AL

Note: When using the vent limiting device, regulator must be mounted in a horizontal upright position for best performance. Vent limiters must be screwed directly into the regulator vent boss and no intervening piping is allowed.

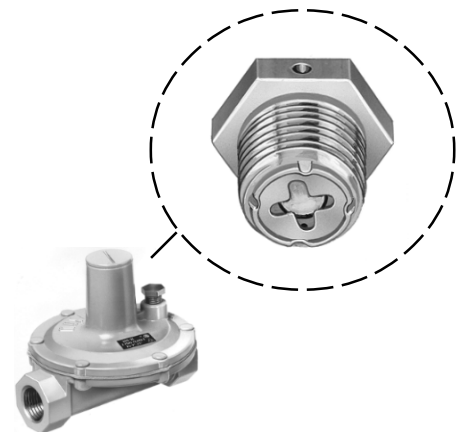

A copyrighted publication of

MAXITROL[®]  **company**
www.maxitrol.com

Maxitrol Company
23555 Telegraph Rd., P.O. Box 2230
Southfield, MI 48037-2230 U.S.A.
248.356.1400 • Fax 248.356.0829

European Representatives
Warnstedter Strasse 3, 06502 Thale, Germany
49.3947.400.0 • Fax 49.3947.400.200
Industriestrasse 1, 48308 Senden, Germany
49.2597.9632.0 • Fax 49.2597.9632.99