



Powering Business Worldwide

## Installing and Testing an AF/GF Receptacle

Please read this leaflet completely before getting started.

www.eaton.com  
www.eaton.com/wiringdevices  
EIS-0166-E (REV. A)

### CAUTION

- To prevent severe shock or electrocution, always turn the power OFF at the service panel before working with wiring.
- Use this AF/GF receptacle with copper or copper-clad wire. Do not use it with aluminum wire.
- Do not install this AF/GF receptacle on a circuit that powers life support equipment because if the AF/GF trips it will shut down the equipment.
- Must be installed in accordance with national and local electrical codes.
- This Outlet Branch Circuit AF/GF must be installed as the first outlet in the branch circuit.
- If the device trips, note the trip code (blinking LED pattern) before the device is reset in order to diagnose the cause of the trip

### 1. What is an AF/GF?

An Outlet Branch Circuit AF/GF is different from conventional receptacles. It is intended to provide protection of branch circuit wiring, cord sets, and power-supply cords connected to it against the unwanted effects of arcing. In the event of an arcing fault, an AF/GF will trip and stop the flow of electricity to mitigate the risk of fire ignition if the arcing persisted. In the event of a ground fault, an AF/GF will trip and quickly stop the flow of electricity to prevent serious injury.

#### Definition of an arcing fault:

An arcing fault is an unintentional arcing condition in a circuit. Arcing occurs as a normal condition in some motors or when a switch opens. An example of unintentional arcing would be arcing that occurs due to severed power-supply cord conductors.

#### Definition of a ground fault:

Instead of following its normal safe path, electricity passes through a person's body to reach the ground. For example, a defective appliance can cause a ground fault.

An OBC AF/GF does not protect against circuit overloads, short circuits or against shock hazards.

### 2. The AF/GF's features

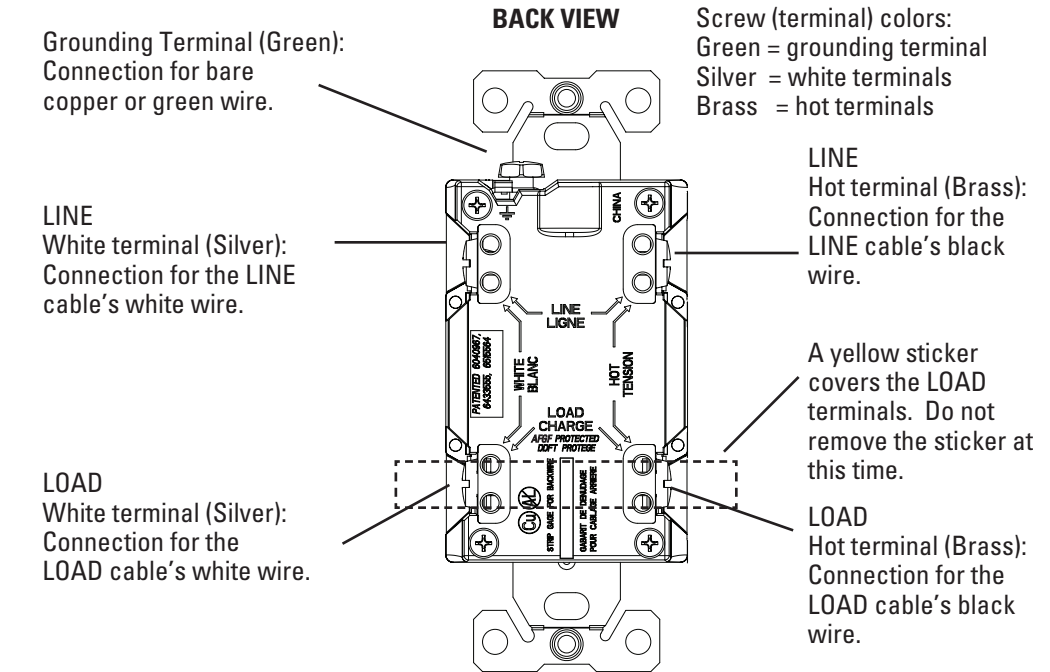
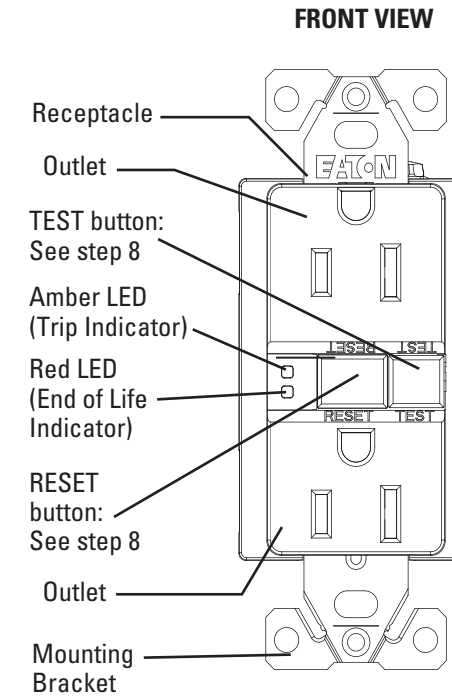

### 3. Should you install it?

Installing a AF/GF receptacle can be more complicated than installing a conventional receptacle.

Make sure that you:

- Understand basic wiring principles and techniques
- Can interpret wiring diagrams
- Have circuit wiring experience
- Are prepared to take a few minutes to test your work, making sure that you have wired the AF/GF receptacle correctly.

### 4. LINE vs. LOAD

A cable consists of 2 or 3 wires.

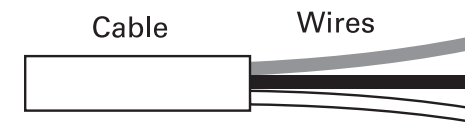

#### LINE cable:

Delivers power from the service panel (breaker panel or fuse box) to the AF/GF. If there is only one cable entering the electrical box, it is the LINE cable. This cable should be connected to the AF/GF's LINE terminals only.

#### LOAD cable:

Delivers power from the AF/GF to another receptacle in the circuit. This cable should be connected to the AF/GF's LOAD terminals only. The LOAD terminals are under the yellow sticker. Do not remove the sticker at this time.

### 5. Turn the power OFF

Plug an electrical device, such as a lamp or radio, into the receptacle on which you are working. Turn the lamp or radio on. Then, go to the service panel. Find the breaker or fuse that protects that receptacle. Place the breaker in the OFF position or completely remove the fuse. The lamp or radio must turn OFF.

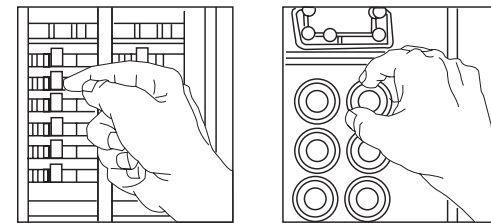

Next, plug in and turn ON the lamp or radio at the receptacle's other outlet to make sure the power is OFF at both outlets. If the power is not OFF, stop work and call an electrician to complete the installation.

### 6. Identify cables/wires

#### Important:

Do not install the AF/GF receptacle in an electrical box containing (a) more than 4 wires (not including the grounding wires) or (b) cables with more than two wires (not including the grounding wire). Contact a qualified electrician if either (a) or (b) is true.

If you are replacing an old receptacle, pull it out of the electrical box without disconnecting the wires.

- If you see one cable (2-3 wires), it is the LINE cable. The receptacle is probably in position C (see diagram to the right). Remove the receptacle and go to step 7A.
- If you see two cables (4-6 wires), follow the procedure to the right. The receptacle is probably in position A or B (see diagram to the right).

#### Procedure: box with two cables (4-6 wires)

- Detach one cable's white and hot wires from the receptacle and cap each one separately with a wire connector. Make sure that they are from the same cable.
- Re-install the receptacle in the electrical box, attach the faceplate, then turn the power ON at the service panel.
- Determine if power is flowing to the receptacle. If so, the capped wires are the LOAD wires. If not, the capped wires are the LINE wires.
- Turn the power OFF at the service panel, label the LINE and LOAD wires, then remove the receptacle.
- Go to step 7B.

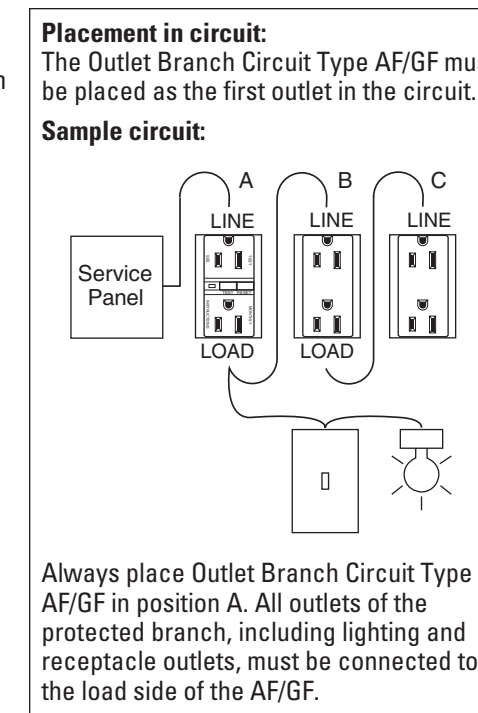

## 7. Connect the wires (choose A or B) ... only after reading other side completely

### A: One cable (2 or 3 wires) entering the box

OR

### B: Two cables (4 or 6 wires) entering the box

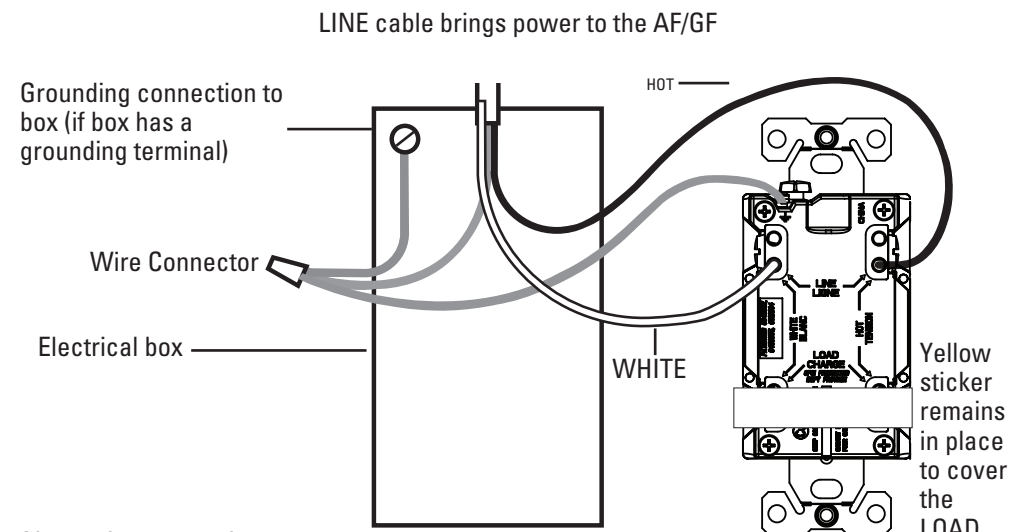

About wire connections:

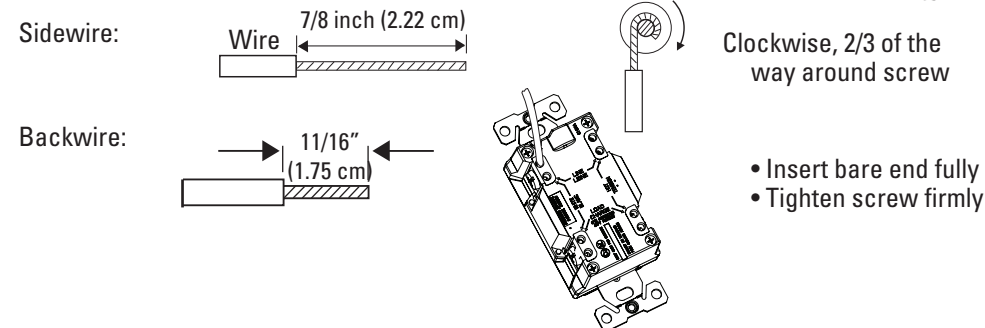

#### Connect the LINE cable wires to the LINE terminals:

- The white wire connects to the White terminal (Silver)
- The black wire connects to the Hot terminal (Brass)

#### Connect the grounding wire (only if there is a grounding wire):

- For a box with no grounding terminal (diagram not shown): Connect the LINE cable's bare copper (or green) wire directly to the grounding terminal on the AF/GF receptacle
- For a box with a grounding terminal (diagram shown above): Connect a 6-inch bare copper (or green) 12 or 14 AWG wire to the grounding terminal on the AF/GF. Also connect a similar wire to the grounding terminal on the box. Connect the ends of these wires to the LINE cable's bare copper (or green) wire using a wire connector. If these wires are already in place, check the connections.

#### Complete the installation:

- Fold the wires into the box, keeping the grounding wire away from the White and Hot terminals. Screw the receptacle to the box and attach the faceplate.
- Go to step 8.

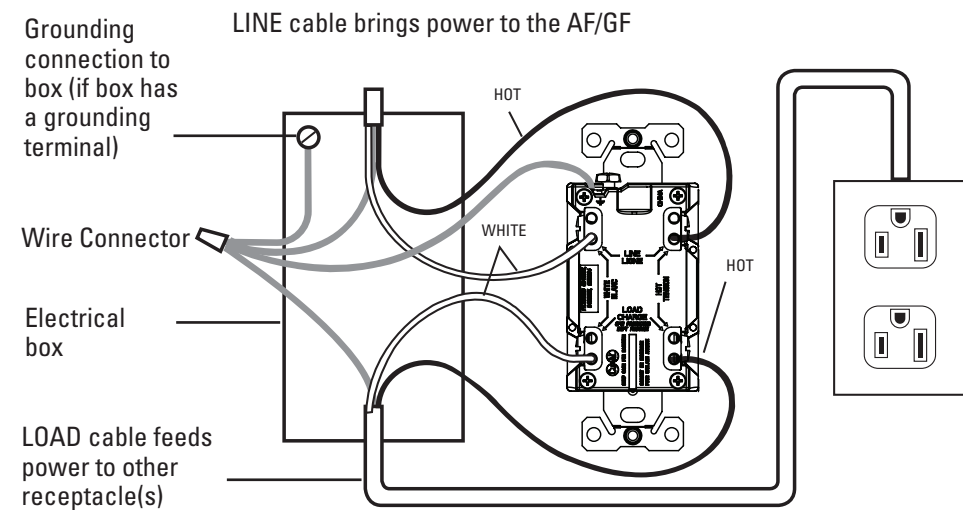

About wire connections:

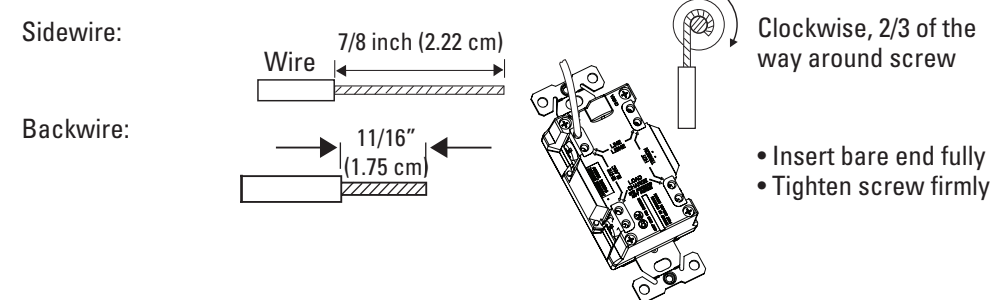

#### Connect the LINE cable wires to the LINE terminals:

- The white wire connects to the White terminal (Silver)
- The black wire connects to the Hot terminal (Brass)

#### Connect the LOAD cable wires to the LOAD terminals:

- Remove the yellow sticker to reveal the LOAD terminals
- The white wire connects to the White terminal (Silver)
- The black wire connects to the Hot terminal (Brass)

#### Connect the grounding wires (only if there is a grounding wire):

- Connect a 6-inch bare copper (or green) 12 or 14 AWG wire to the grounding terminal on the AF/GF. If the box has a grounding terminal, also connect a similar wire to the grounding terminal on the box. Connect the ends of these wires to the LINE and LOAD cable's bare copper (or green) wire using a wire connector. If these wires are already in place, check the connections.

#### Complete the installation:

- Fold the wires into the box, keeping the grounding wire away from the White and Hot terminals. Screw the receptacle to the box and attach the faceplate.
- Go to step 8.

## 8. Test your work

### Why perform this test?

If you miswire the AF/GF, it may not prevent personal injury or death due to a ground fault (electric shock).

Upon initial installation, if you mistakenly connect the LINE wires to the LOAD terminals, this Eaton AF/GF will not be able to be reset, and will therefore not provide power to its receptacle face or load terminals.

### Procedure:

- Turn the power ON at the service panel. Press the RESET button fully. Plug a lamp or radio into the AF/GF (and leave it plugged in) to verify that the power is ON. If there is no power, go to Troubleshooting.
- Press the TEST button in order to trip the device. This should stop the flow of electricity, making the radio or lamp shut OFF and the amber Correct Wiring/Trip Indicator come on. To restore power, press the RESET button.
- If you installed your AF/GF using step 7B, now plug a lamp or radio into surrounding receptacles to see which one(s), in addition to the AF/GF, lost power when you press the TEST button. Do not plug life saving devices into any receptacles that lost power. Place a "AF/GF Protected" sticker on every receptacle that lost power.

(d) Press the TEST button (then RESET button) every month to assure proper operation.

(e) Note that this Eaton AF/GF is shipped in the Tripped state and cannot be Reset until it is wired correctly and powered from its Line terminals.

(f) Note that the RESET button will pop-out. If the power goes OFF and the correct wiring/trip indicator stays on, you have installed the AF/GF receptacle correctly.

(g) LINE/LOAD reversal will be indicated by the reset button not staying in after being pressed. Such LINE/LOAD reversal will also be indicated by failure of the Correct Wiring/Trip Indicator to be on while the AF/GF is tripped.

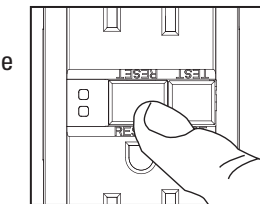
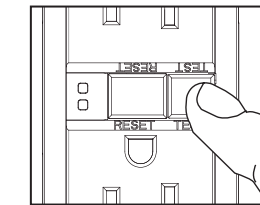
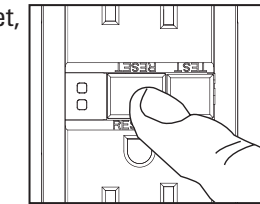

### TROUBLESHOOTING

Turn the power OFF and check the wire connections against the appropriate wiring diagram in step 7A or 7B. Make sure that there are no loose wires or loose connections. Also, it is possible that you reversed the LINE and LOAD connections. Reverse the LINE and LOAD connections if necessary. Start the test from the beginning of step 8 if you rewired any connections to the AF/GF.

#### Ground Fault Self-Test

- AF/GF receptacle periodically performs an internal automatic test of its ability to respond to ground faults.
- Failure of this test means that AF/GF has reached its "end of life". AF/GF will trip and will not reset (no output power), thereby preventing power when no ground fault protection is available
- If the red indicator light on the front of the device is flashing, then AF/GF has reached its "end of life" and should be replaced.

#### General Information

AF/GF ratings:  
15A-125V AC Duplex Receptacle  
20A-125V AC Duplex Receptacle  
All rated 20A feed-through  
125V Class A

## AF/GF Trip Codes

RED LED	AMBER LED	Reset button status	Diagnosis	Action
OFF	OFF	In	Device is functioning properly OR branch circuit may have no power	Manually press the TEST button to trip device. <b>Amber</b> light should come ON • If <b>Amber</b> light does <u>not</u> come ON, check if there is power to the branch • If <b>Amber</b> light does come ON, manually press the RESET button to restore power to the device • If AF/GF receptacle does not reset, replace AF/GF receptacle • If AF/GF does reset, device is functioning properly
OFF	<b>ON</b>	Out	Device is in tripped state (either from manually pressing TEST button or from GFCI trip)	Manually press the RESET button to restore power to the device • If AF/GF receptacle does not reset, replace AF/GF receptacle
OFF	2 blinks	Out	General Series Arc	Manually press the RESET button to restore power to the device • If AF/GF receptacle continues to trip, contact an electrician to locate and repair the series arc fault
OFF	3 blinks	Out	Parallel Arc	Manually press the RESET button to restore power to the device • If AF/GF receptacle continues to trip, contact an electrician to locate and repair the parallel arc fault
OFF	4 blinks	Out	Overvoltage	Manually press the RESET button to restore power to the device • If AF/GF receptacle continues to trip, contact an electrician to locate and repair the overvoltage condition
OFF	5 blinks	Out	AFCI self-test failure	Manually press the RESET button to restore power to the device • If it does not reset and/or the blinking continues, replace the AF/GF receptacle
Blinking	<b>ON</b> or OFF	In or Out	GFCI self-test failure	Manually press the RESET button to restore power to the device • If it does not reset and/or the blinking continues, replace the AF/GF receptacle

### EATON'S LIMITED 2 YEAR WARRANTY

EATON warrants its Arc Fault/Ground Fault Circuit Interrupter (AF/GF) to be free of defects in materials and workmanship in normal use and service for a period of two years from date of original purchase. THIS TWO (2) YEAR LIMITED WARRANTY IS IN LIEU OF ALL OTHER WARRANTIES, OBLIGATIONS, OR LIABILITIES, EXPRESSED OR IMPLIED (INCLUDING ANY IMPLIED WARRANTY OF MERCHANTABILITY OR FITNESS FOR A PARTICULAR PURPOSE THAT IS IN DURATION IN EXCESS OF TWO YEARS FROM THE DATE OF ORIGINAL CONSUMER PURCHASE). NO AGENT, REPRESENTATIVE, OR EMPLOYEE OF EATON HAS AUTHORITY TO INCREASE OR ALTER THE OBLIGATIONS OF EATON UNDER THIS WARRANTY.

To obtain warranty service for any properly installed EATON AF/GF that proves defective in normal use send the defective AF/GF prepaid and insured to Quality Control Dept. EATON, 203 Cooper Circle, Peachtree City, GA 30269.

EATON will repair or replace the defective unit, at its option. EATON will not be responsible under this warranty if examination shows that the defective condition of the unit was caused by misuse, abuse, improper installation, alteration, improper maintenance or repair of damage in shipment to EATON. EATON SHALL HAVE NO RESPONSIBILITY FOR INSTALLATION OF THE AF/GF, OR FOR ANY PERSONAL INJURY, PROPERTY DAMAGE, OR ANY SPECIAL, INCIDENTAL, CONTINGENT, OR CONSEQUENTIAL DAMAGES OF ANY KIND, RESULTING FROM DEFECTS IN THE GFCI OR THE FAILURE OF THE PRODUCT TO FUNCTION IN THE EVENT OF A GROUND FAULT ON ITS PROTECTED CIRCUIT, OR FOR BREACH OF ANY EXPRESS OR IMPLIED WARRANTY ON THIS PRODUCT.

THE EXCLUSIVE REMEDY FOR BREACH OF THE LIMITED WARRANTY CONTAINED HEREIN IS THE REPAIR OR REPLACEMENT OF THE DEFECTIVE PRODUCT AT EATON'S OPTION. IMPLIED WARRANTIES (IF ANY) INCLUDING, BUT NOT LIMITED TO IMPLIED WARRANTIES OF FITNESS FOR A PARTICULAR PURPOSE AND MERCHANTABILITY, ARE LIMITED IN DURATION TO A PERIOD ENDING TWO YEARS FROM THE DATE OF ORIGINAL CONSUMER PURCHASE. IN NO CASE SHALL EATON LIABILITY UNDER ANY OTHER REMEDY PRESCRIBED BY LAW EXCEED THE PURCHASE PRICE. Some states do not allow the exclusion or limitation of incidental or consequential damages or allow disclaimers or modifications of or limitations on how long an implied warranty lasts, so the above limitations may not apply to you. This warranty gives you specific legal rights and you may also have other rights which vary from state to state. Read enclosed instructions carefully.