

# HISTORIC STRUCTURE REPORT

SOUTHWEST REGION HEADQUARTERS BUILDING  
SANTA FE, NEW MEXICO



STEVEN M. BURKE AND  
MARLYS BUSH THURBER

NATIONAL PARK SERVICE

SOUTHWEST REGION HEADQUARTERS BUILDING

Santa Fe, New Mexico

A Historic Structure Report

by Steven M. Burke  
Marlys Bush Thurber

Southwest Cultural Resources Center Professional Paper No. 6  
U.S. Department of the Interior  
National Park Service  
Santa Fe, New Mexico  
March 1985

RECOMMENDED:

  
Associate Regional Director,  
Planning and Cultural Resources

5/2/85  
Date

  
Associate Regional Director, Administration

5/3/85  
Date

APPROVED:

  
Regional Director, Southwest Region

5/3/85  
Date

CONCURRED:

  
GSA Buildings Manager

5-13-85  
Date

## TABLE OF CONTENTS

LIST OF ILLUSTRATIONS.....	vii
CONTRIBUTORS.....	xi
INTRODUCTION: AN HISTORICAL OVERVIEW.....	1
Location and Site Selection.....	1
Architectural Style.....	6
The Project Designers.....	7
The Construction Phase.....	7
Regional Office Administration and Staff, 1937-1939.....	12
CHAPTER 1: THE BUILDING AS ORIGINALLY CONSTRUCTED.....	15
General Description.....	15
Description of the Building Exterior.....	31
Entrances.....	31
Roof.....	31
Columns, Vigas and Corbels.....	32
Outbuildings.....	37
Service Building.....	37
Greenhouse.....	37
Description of the Building Interior.....	37
Layout of the Structure.....	37
Doors and Windows.....	40
Ceiling Construction.....	40
The Entry Foyer and Stairs.....	46
The Regional Director's Office.....	46
Electrical, Heating and Sewer System.....	49
Electrical.....	49
Heating.....	49
Sewer.....	49
Walks, Walls and Parking.....	53

CHAPTER 2: LANDSCAPE.....	59
Parking Areas.....	59
Patios.....	59
Other Landscaping.....	68
CHAPTER 3: FURNISHINGS.....	71
The Furniture Designer and Builder.....	71
Conference Room Furniture.....	71
Chairs.....	71
Small Table.....	71
Large Table.....	73
Foyer.....	73
Large Desk.....	73
Coffee Table and Chairs.....	73
Other Original Furnishings.....	80
Patio Benches.....	80
Oil Painting.....	80
Fixtures.....	83
Balustrades.....	83
CHAPTER 4: BUILDING ALTERATIONS AND ADDITIONS IN THE 1940s AND 1950s.....	85
1941.....	85
Stair Alterations.....	85
Proposed Library Addition.....	85
Service Building Addition.....	85
1942.....	93
East Patio.....	93
1949.....	93
Drafting Room Changes.....	93
1956.....	93
West Basement Remodeling.....	93

CHAPTER 5: ADDITIONS AND ALTERATIONS FROM THE 1960s TO THE PRESENT.....	99
1964.....	99
Service Building Alterations.....	99
1967.....	99
Repairs to Vigas, Canales and Wood Posts.....	99
Wall Repairs and Painting.....	100
Windows and Doors.....	104
Basements.....	104
Mechanical System.....	105
Service Building and Greenhouse Alterations.....	105
Walls.....	105
1969.....	108
Portal Offices.....	108
1972.....	108
Upstairs Bathroom.....	108
1974.....	108
Drafting Room.....	108
1982.....	108
Handicapped Requirements.....	108
RECOMMENDATIONS.....	113
Examples of Architectural Elements Warranting Preservation.....	113
Current Maintenance Items.....	114
Priority Maintenance List.....	115
Treatment Recommendations.....	120
Roof Replacement and Parapet Repair.....	120
Repair of Wood Members.....	120
Canales.....	120
Viga Repair and Replacement.....	120
Epoxies.....	121
Removal of Paint from Posts and Corbels.....	122
Possible Replacement of Portal Posts.....	123
Outbuildings.....	123
Service Building.....	123
Greenhouse.....	124
Doors and Windows.....	125
Hardware Replacement.....	125
Ceilings.....	127

Confining Walls.....	127
Parking Areas.....	127
Landscaping.....	127
Pool and Fountain.....	127
Large Patio.....	128
Building Grounds.....	128
Furniture.....	128
Cleaning Dirty Furniture.....	129
Repairing Surface Scratches.....	130
Fixtures.....	130
Light Fixtures.....	130
Interior Walls.....	131
Floors.....	131
Restrooms.....	131
Foundations.....	132
APPENDIX A.....	133
APPENDIX B.....	137
APPENDIX C.....	139
APPENDIX D.....	142
APPENDIX E.....	143
APPENDIX F.....	147
BIBLIOGRAPHY.....	149

## LIST OF ILLUSTRATIONS

Figure 1.	North elevation of the Region III headquarters, 1939.....	xii
Figure 2.	A view of the Region III building while under construction.....	11
Figure 3.	The patio pool and fountain, 1939.....	12
Figure 4.	Elevtions showing portals, building massing, and window and door layout, 1939.....	14
Figure 5.	North entrance door details, 1939.....	16
Figure 6.	Elevation showing entrance motif and stone foundation, 1939.....	34
Figure 7.	An entrance addition on the building's south side.....	35
Figure 8.	Roof and flashing details, 1939.....	36
Figure 9.	A detail of a column showing how it was attached to the flagstone base, 1939.....	38
Figure 10.	A detail of a foyer corbel, 1939.....	39
Figure 11.	Details showing the original greenhouse, 1940.....	41
Figure 12.	A Dutch style door built for the files room, 1939.....	42
Figure 13.	A detail of the door from the foyer to the patio, 1939.....	43
Figure 14.	Door and window schedules, 1939.....	44
Figure 15.	East and west drafting room ceiling details, 1939.....	45
Figure 16.	Entrance motif and stair details, 1939.....	47
Figure 17.	Details of the kiva fireplaces in the second floor offices, 1939.....	48



Figure 18.	The information counter showing how a steam heat radiator was built into it, 1939.....	50
Figure 19.	Plan view of pipe tunnels.....	51
Figure 20.	Heating plan units nos. 1 and 2, 1938.....	52
Figure 21.	Plan showing current parking spaces available.....	54
Figure 22.	Entrance sign details, 1939.....	55
Figure 23.	A composite plan and section of the entrance and steps, 1939.....	56
Figure 24.	Original planting plan, 1939.....	58
Figure 25.	Planting plan showing existing and new landscaping at time of construction.....	60
Figure 26.	Conference room patio plan showing the original landscaping, 1939.....	61
Figure 27.	A photograph showing an adobe banco in the large patio, 1939.....	62
Figure 28.	A photograph of the pool and fountain just after completion.....	64
Figure 29.	The fountain basin as originally designed, 1939.....	65
Figure 30.	Pool and fountain details showing the overflow basin and the current basin design, 1939.....	66
Figure 31.	A drawing of the fountain showing the flagstone coping and the glazed rim basin, 1938.....	67
Figure 32.	Hand-carved chairs designed for around the conference room table, 1939.....	70
Figure 33.	Conference room chairs, 1939.....	72
Figure 34.	A small hand-carved table designed for the conference room, 1939.....	74

Figure 35.	Details showing the large conference room table and a desk in the foyer, 1939.....	75
Figure 36.	Coffee table and chairs designed for the foyer, 1964.....	78
Figure 37.	Chairs for the foyer coffee table, 1964.....	79
Figure 38.	Patio bench details, 1939.....	81
Figure 39.	Oil painting of Stephen T. Mather as originally hung in the conference room.....	82
Figure 40.	Spanish style hand-carved balustrade located in the Public Affairs office, 1939.....	84
Figure 41.	The original and existing handrail located on the stairway to the second story, 1939.....	86
Figure 42.	Alterations to the stair, 1941.....	87
Figure 43.	Stairway alteration and details of a proposed handrail, 1941.....	94
Figure 44.	The front elevation of the service building, 1941.....	95
Figure 45.	Detail showing the 8 foot vertical logs used on the service building's east wall, 1941.....	96
Figure 46.	Alterations to the west basement, 1956.....	97
Figure 47.	Viga removal and repair plans, 1967.....	98
Figure 48.	Parapet, confining walls and wood post details, 1967.....	101
Figure 49.	A plan view showing cracks on both the interior and exterior walls, 1967.....	102
Figure 50.	Elevations showing a number of exterior cracks, 1967.....	103
Figure 51.	Mechanical details showing the addition of attic exhausters and exhaust grills, 1967.....	106

Figure 52.	Details showing the original greenhouse that was removed and replaced with a smaller one, 1967.....	107
Figure 53.	A floor plan of rooms 109, 110 and 111 showing alterations, 1969.....	109
Figure 54.	Details showing new drafting room partitions, 1974.....	110
Figure 55.	Evolution of spaces in 1938.....	134
Figure 56.	Evolution of spaces in 1950.....	135
Figure 57.	Evolution of spaces in 1984.....	136
Figure 58.	Plat plan.....	138
Figure 59.	Floor plan showing the current fire alarm system, 1983.....	141
Figure 60.	Photographs showing some of the original hardware, 1984.....	145
Figure 61.	Original patio gate hardware made in Santa Fe, 1939.....	146

## CONTRIBUTORS

This report was funded in part by the General Services Administration, Santa Fe Office, Leon Hernandez, Director.

It was produced under the direction of Marlys Bush Thurber, Historical Architect, Southwest Cultural Resources Center. Steven M. Burke conducted the research, selected the graphic illustrations, did layout and paste-up, and wrote major portions of the study. Mary Ryan Volkert produced and edited the document on the Data General CEO Word Processing System. Sam Romero, Division of Maintenance, Southwest Region, helped in locating the original drawings.

At Denver Service Center, George Thorson, Supervisory Historical Architect, Southeast/Southwest Team, provided work space and supervisory support in the production of the report. DSC's Branch of Micrographics also shared their expertise in photographic reproduction.

Thomas DuRand, Harpers Ferry Photo Library, and Mark Sawyer, Western Archeological Conservation Center, provided historic photographs from their respective collections.

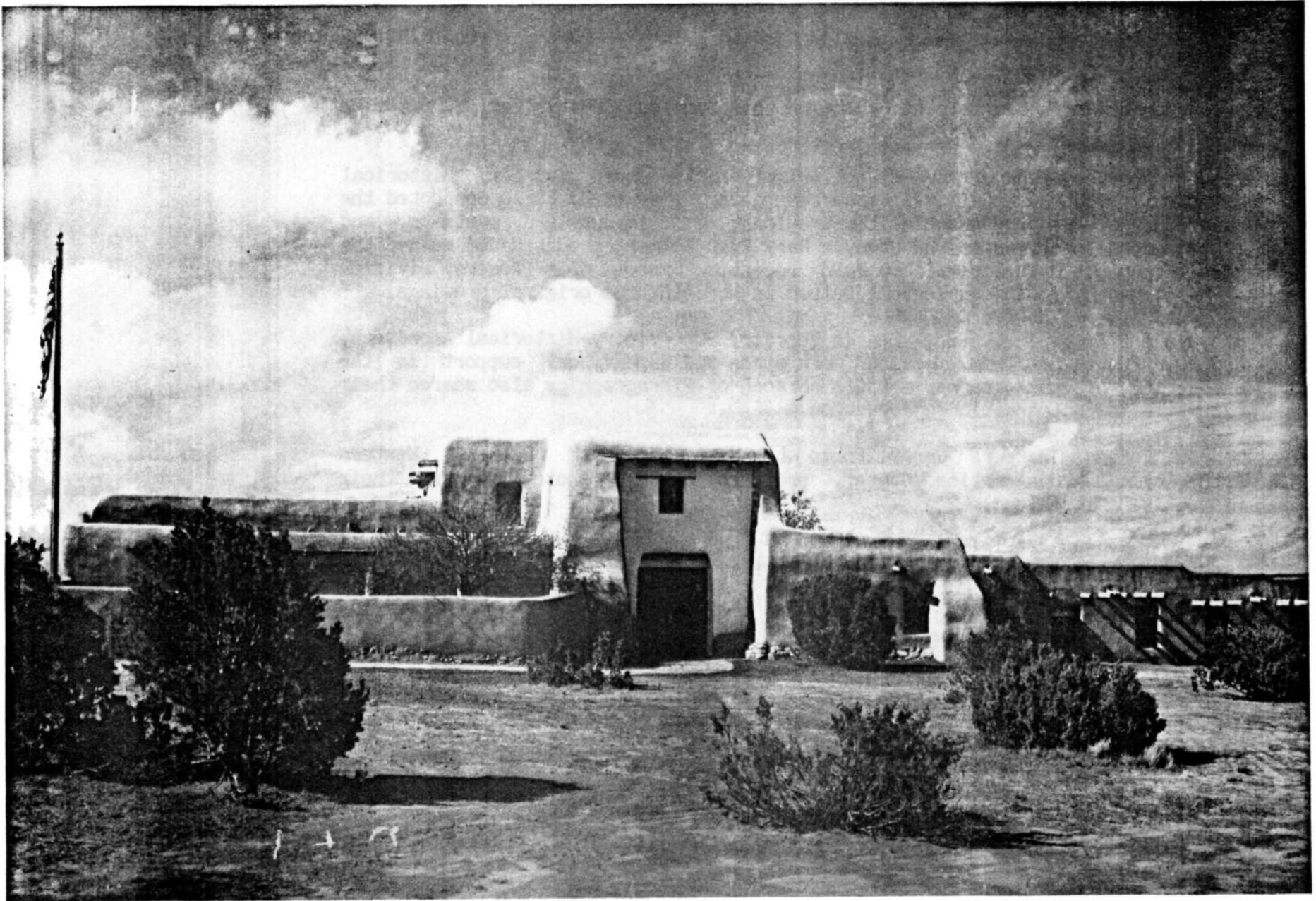

Figure 1.

The north front of Region III headquarters, July 29, 1939.

INTRODUCTION: AN HISTORICAL OVERVIEW

Location and Site Selection

The Southwest Regional Office building, National Park Service in Santa Fe, New Mexico, is thought to be the largest adobe office building in the United States. The 24,000 square foot building, now listed on the National Register of Historic Places, is located on Old Santa Fe Trail off Camino del Monte Sol in the foothills of the Sangre de Cristo Mountains ("Park Service Moves," Santa Fe New Mexican, July 1, 1939), (Figure 1).

In 1937 Santa Fe was chosen as the permanent site for the headquarters of what was then Region III of the National Park Service. Santa Fe's location as the approximate geographic center of the Region, the mild climate, and the area's general appeal to visitors and Park Service personnel alike were important factors in its selection.

As mentioned in the following letter, Santa Fe's Laboratory of Anthropology offered to donate the 8.5 acre site to the Federal Government for the headquarters building. A condition of the donation was that the government would use the land for no purpose other than the Regional Office building. Harold L. Ickes, Secretary of the Interior, accepted the Laboratory's offer and its stipulations (Ibid.).

U. S. Court House  
Santa Fe, N.M.

November 8, 1937

Director,  
National Park Service,  
Washington, D. C.

Subject: Unit One, Region Three Hqns.  
Bldg., Santa Fe, N. M.

Dear Sir:

There are attached hereto plans for Unit One of the headquarters building for Region Three, to be erected at Santa Fe. These plans consist of working drawings for Unit One as well as smaller photostatic prints of the first and second floor layouts showing the ultimate development. It will be seen from this that we are regarding the building as a two-unit job plus the Utility Area.

To date we have cleared the site, excavated for the basement, and have manufactured some 50,000 adobes which is about half the number that will be required for the first unit. The construction is to be of adobe throughout, with two coats of Bitudobe stucco over the exterior. We expect to start excavation for the foundation trenches this week.

The general plan of the entire layout as shown is very much the same as was originally proposed in the preliminary sketches which went to the Secretary for approval of the PWA appropriation.

We think it will be generally admitted that it is very difficult to plan a regional headquarters, looking into the distant future, when it cannot be accurately antic-

ipated as to just how extensive such a headquarters will need be and how large a staff will from time to time be housed therein. We have given a great deal of consideration to this in discussion with members of the Washington office, and we feel that we have solved the problem by planning the building in such a manner that extreme expansion or shrinkage of the regional staff will be possible without disturbing the functioning of the building. In regarding the floor plan of Unit One (administration and general office), it will be observed that such rooms as Files, Mails, Supplies and Conference Room are generous in proportion, although the General Office has been designed large enough to comfortably take care of our present general office staff. In other words, if it becomes necessary in years to come to materially increase the size of the general office staff, for some reason or other, the General Office room could reach out and take in, let us say, the room which is for files, and this room and the other rooms could move around one step each absorbing the room which is now marked Conference.

In the case of the technician's offices in Unit Two, (not now being submitted) these offices are being shown as not too large for the use of one man where only one branch representative is on the staff, but these offices have been made large enough that 4 to 5 desks could be placed in them if any branch expanded or if it were necessary to call men in from the national parks for various periods of time. This also applies to the drafting facilities. In other words, we have, after two months of intensive thought developed what we feel will be a headquarters not uncomfortably roomy for a small staff and not too tight for a large staff should considerable temporary or permanent expansion eventuate.

Of course several other offices or facilities might be included that have not been provided for in this plan. For instance, we feel that a regional headquarters should eventually include provision for museum preparation since, with the extensive museum program which developed during the past few years, the maintenance work on museum exhibits, as well as periodic new exhibits, etc., will call for al-



most continual work of this kind at some central point in the region. The reducing of the Berkeley and the Washington museum staffs will probably contribute to this. In addition to the above, an office might be provided for the Regional Auditor as well as one for the individual handling Public Information (publicity).

It will be observed that while space provision has been made on the plans for the central heating plant in the basement, the boilers and radiators as such are not shown on the plans or included in the material list, although all heating piping is to be roughed in. It is expected to obtain the boilers and radiators from surplus War Department supplies, or from some other source. The boilers are to be in series and can be added to when Unit Two is undertaken.

The second story affords roomy administration offices. It may be practical when, as now, two Assistant Regional Directors are assigned, to locate both in one office, however, it is felt the additional office as shown allows for some expansion.

It will be noted further that we have included an office on the second floor for visiting national park superintendents, and travelers from the Washington Office.

It is estimated that the abstract work on the land being donated will amount to \$100 and this will leave \$2400 from our PNA allotment for materials. Our material list on Unit One indicates proposed expenditures totaling approximately \$2,000 at this time from the PNA allotment of \$2500.

If there is any question regarding any item in connection with this project, which is under SP-1 Hyde Park, please wire us since we are most anxious to get these working drawings on the job.

Yours very truly,

Herbert Maier  
Acting Regional Director

HM/o

P.S: A copy of the deed to the eight acres, which has been drawn up between this office and the Laboratory of Anthropology, is being sent to Mr. Moskey for his review and comment. The Trustees for the Laboratory will meet in New York City in about two weeks at which time the deed will be made over to the Federal Government.

It will be observed that the total costs of Unit One, including the money we are to spend for materials from PWA allotment of \$2500, totals something below \$25,000. The only fiscal difficulty we anticipate is in the purchase of some of the materials which cannot be undertaken until after July 1, 1928, when additional funds for the next period will be available. We hope to get Unit One completed by the end of the coming summer.

There has been some question in our mind as to the procedure in connection with the approval of this job. Admittedly it is a job under Hyde Park SP-1, N.M., and normally approval would rest with the Inspector. On the other hand, the building is to be erected on land which will be classified as a Federal area. The customary title block for a State Park job has been used, calling for the signature of the Assistant Director, and we presume this is quite all right since the space available can be adjusted for any signature desired in Washington.

We do not know to what extent review by various administrative and technical men in the Washington office will be desirable on this particular job. Undoubtedly the Director's approval will be necessary and desirable. We suggest that in general discussion the photostatic prints of the first and second floor be made use of rather than the working drawing blue prints since the latter will be more difficult for some to comprehend.

All requisitions have been drawn up and purchases of materials will be undertaken immediately word of approval which we urge you wire us, has been received.

### Architectural Style

Architectural form and settlement patterns in New Mexico were determined largely by fear of the enemy and the scarcity of local building materials. By the late 1860s, when the United States began building military forts in the southwest, Pueblo Indian and Spaniard alike had built fortified enclosed spaces for safety. Readily available materials consisted of adobe and stone for walls, adobe mud for mortar, and rough cut timber for roof framing. Both Pueblo and Spanish buildings were simple structures, rectangular in plan with few door and window openings. They were massive in size yet gentle in contour, with soft curves in the mud-plastered walls. Multi-storied and terraced structures had evolved as early as the 10th century.

In the early 1900s, the unique elements of the Spanish-Pueblo architecture were being revived. Cheap handcrafted labor, the ready availability of adobe as a building material, and unrestricted zoning regulations gave southwestern towns unique character. Still evident today are narrow winding streets shaded by large cottonwood trees and the soft flowing lines of adobe patio walls.

The Regional Office building was designed in the Pueblo-Spanish style, and like many traditional Spanish buildings, it is laid out to enclose a large open courtyard or patio. Other than the executive offices in the two-story part of the building, most of the rooms open out onto a portal bordering the 75-foot by 90-foot<sup>2</sup> patio (Maier, "Old Spanish Styles," Santa Fe New Mexican, July 1, 1939).<sup>2</sup>

Many architects remarked on the suitability of the building's style. Among these was the Senior Architect of the National Park Service, Albert H. Good, who came on a visit from Washington shortly after the building had opened. Good described the structure as "a sincere adaptation of the early architecture of New Mexico." In contrast to Modern or the "International Style" of architecture prevalent in the 1930s, Good felt that the Pueblo-Spanish style had intrinsic popular appeal. He went on to state: "There is probably in the United States no traditional architecture so kindred and complementary to it as the early architecture of the southwest ("Early Spanish Architecture," Santa Fe New Mexican, July 1, 1939)."

### The Project Designers

Associate Architect for the National Park Service and Architect for the Regional Office building, Cecil J. Doty came to Santa Fe in 1937 and rapidly absorbed the elements of the native style. Doty, who studied architecture at Oklahoma A&M, formerly had worked for firms in Oklahoma and Kansas. In the early 1930s, the architect had taught free-hand design at the University of Oklahoma until his employment by the National Park Service in 1934 (Maier:July 1, 1939).

The building's landscape was designed by Harvey Cornell, Regional Landscape Architect in the Santa Fe office, and was carried out by Associate Landscape Architect John Kell. Cornell, a graduate of Iowa State College and Harvard University, had been in charge of Harvard's landscape architecture program for a 2-year period. He later spent 8 years in private practice in Minnesota, and had also taught in the University of Minnesota's Department of Architecture and Horticulture (Ibid.).

### The Construction Phase

Once the design for the building was completed, construction began by the Civilian Conservation Corps (CCC) and the Works Progress Administration (WPA). Local Santa Fean and retired Associate Regional Director Carl Walker remembered watching the building take shape on the acre it covered 1 mile west of Santa Fe. Walker said, "If workers didn't know how to make adobes before, they did by the time the building was completed."<sup>3</sup>

In an interview on January 24, 1985, Carl Walker stated that he did not actually work on the building, but was a member of the camp that did. "Actually much of the building was constructed after I got out of the camp in December 1936," said Walker. Also mentioned was the fact that the building was started by the WPA in 1937 and taken over and finished by the CCC from 1938 to 1939.<sup>2</sup>

The local CCC camp employed 104 single men between the ages of 17 and 23-1/2 all of which were from needy families. The Corps members were paid \$30 per month plus room and board and \$22 to \$25 was deducted and sent directly to their families at home ("CCC Camp," Santa Fe New Mexican, May 18, 1937).

Getting the CCC commitment for the construction had involved the right timing. Conrad Wirth, who was in charge of organizing CCC work in the national parks, tells how he persuaded the Corps' National Director Robert Fechner on an airplane trip to El Paso (Herbert Maier, Regional Director for the Southwest Region, was also a passenger):

It just happened that Herb Maier and I had a very important question to ask Fechner, and we were trying to find the right time to do it. Although we felt he would not turn us down, we needed his specific approval. About a half hour after taking off Fechner was dozing and nodding. I told him we had plans for constructing a building in Santa Fe as the Regional Office for the Park Service. The CCC boys would make the adobe bricks and would do a good part of the construction, but we had some Public Works Administration funds for materials and skilled labor. We told him that a museum in Santa Fe would give us the property on condition that it would only be for the National Park Service Regional Office building. He said, "That sounds reasonable." I continued, "Bob, I think we need your approval of it--it's a fairly good-sized project and I have the plans here." You could tell that Bob Fechner was not too anxious to get into much of a discussion; he was more in the mood for a nap. He said, "Well, if it meets the legal requirements and you think it's all right, Connie, go ahead. It will be all right with me." Herb Maier must have called Santa Fe as soon as we reached El Paso and told them to go ahead, or perhaps he had even started before we had Fechner's approval, because when we arrived in Santa Fe about 5 days later the foundations were being dug (Wirth 1980:120).

Working as a company, and with little or no building experience, the CCC members were active in much of the construction. The Corpsmen helped to prepare the site and, as the list below indicates, they made more than 280,000 adobe bricks from the excavated soil. The adobes would not be used sparingly. The base of the walls of the two-story portion of the building are about 3 feet thick ("section," Figure 16), and are supported by foundations of natural stone ("Welcome Letter," National Park Service).

Justification:

In conjunction with the construction of the new Regional Office Building, Camp SP-1-N proposes to manufacture the adobe bricks estimated to 100,000.

The work of Camp SP-1-N under this Job 138 will be preparation and transportation of materials to be used in construction of the Regional Office Building.

Adobe soil of good quality is available on the job site, and it is proposed to remove the soil for adobe manufacture from the basement area and to excavate the basement at the same time adobes are made. At the present time water is available at the property line approximately 300 feet from the building location. In order to get water for adobes it is proposed under the job application to dig a trench and install a permanent line from the property line to within a few feet of the building location. A meter will be installed and a temporary line laid to the building location to furnish water for adobes.

In addition to the manufacture of adobes a crew of men will be assigned to cutting Vigas and Aspen poles for ceiling and other construction. A second crew will secure stone for the basement and footings; while a third crew will secure flagstone for floors and walks. A breakdown of mandays cost is given on page 4.

Preparation work will be complete but a separate job will be submitted with plans and specifications for actual building construction.

EQUIPMENT REQUIREMENTS

List equipment items essential for completion of job, and state whether available or not.

Hand Tools	:	
Trucks	:	
Winch	:	:::::::::: All Available at Camp SP-1-N.
Concrete Mixer	:	

One additional concrete mixer will be needed.

REQUIREMENTS

1. Bill of Materials: unit and total price. Differentiate between emergency funds and contributions by park authority or sponsor.
2. Skilled Labor: Number of hours contemplated, hourly rate and total cost for each type of labor, except CCC.
3. Equipment: Rental only--type, hourly rental, total cost, include operator when necessary

Manday Estimate: Breakdown as follows:

- |   |                |
|---|----------------|
| (1) Laying 250 feet of water pipe, plus connections and water meter, in trench from main line to building site; | 50 mandays.    |
| (2) Mixing and pouring 100,000 adobe bricks, and piling;  | 2000 mandays.  |
| (3) Cutting and transporting Vigas and Aspen poles for roof and ceiling construction;                           | 500 mandays.   |
| (4) Quarrying and transporting 100 cubic yards of stone for foundations, and flagstone for walks;               | 950 mandays.   |
| Total   | 3,500 mandays. |

SPECIFICATIONS

Include a brief set of specifications, with a description of the proposed procedure and methods. This is mandatory for all road and structural jobs

- 1.) Adobes to be 10" x 14" x 4" mixed with straw in the usual manner.
- 2.) Specifications for Vigas and other timbers to be furnished by the Architect in charge of Design and Construction.
- 3.) Other specifications to be submitted with the plans for the building.

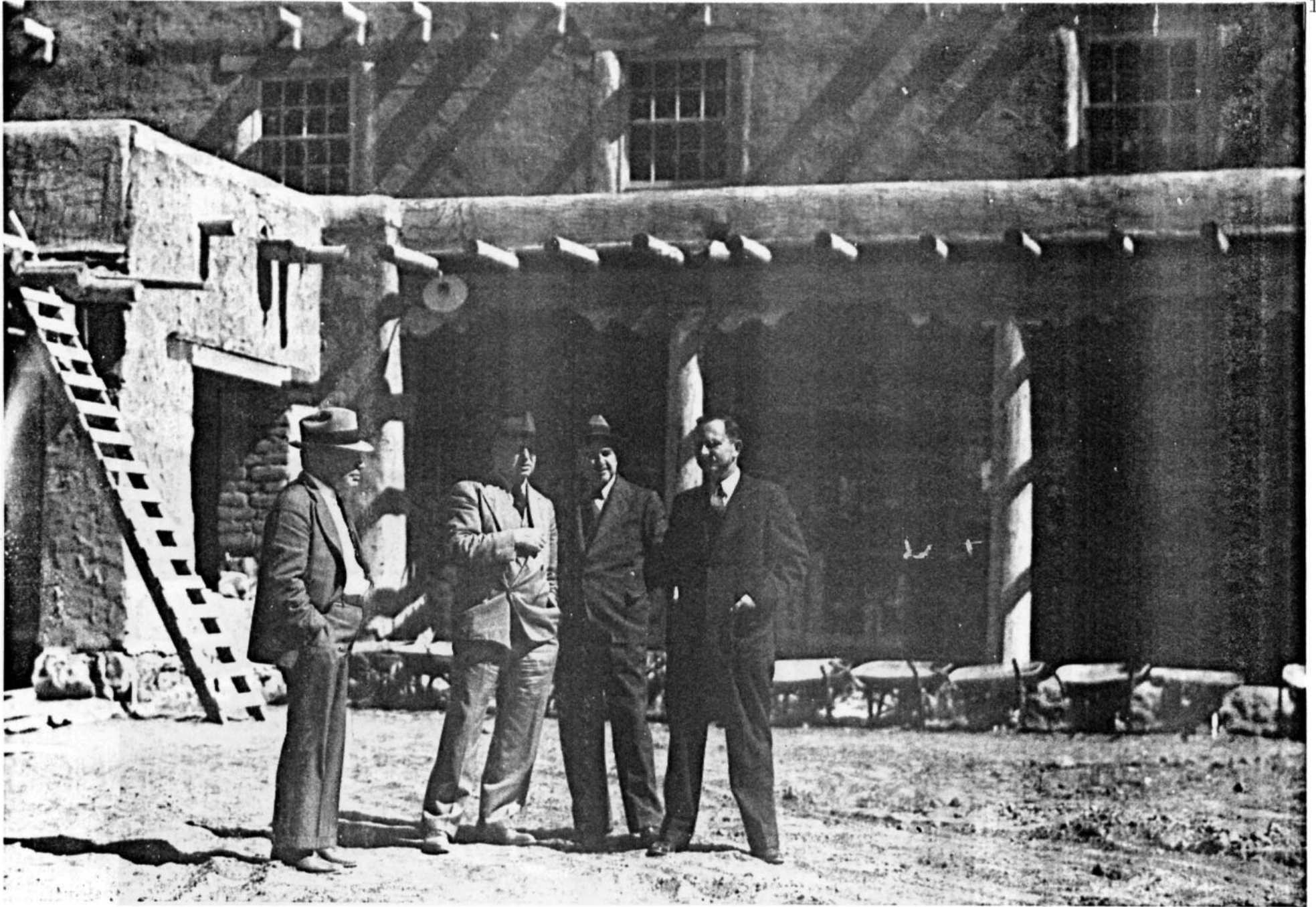

Figure 2.

A view of the Region III building from inside the patio looking toward the administration section. Observing the new office building are from left to right: Charles Gable, Herb Maier, Tom Boles and Hugh Miller.



Regional Office Administration and Staff, 1937-1939

On October 9, 1937, when construction of the building was barely underway, the Region III headquarters was officially transferred from Oklahoma City to the new Santa Fe location. Herbert Maier headed a Regional staff of 52 people, 35 from the Oklahoma City office and 17 already stationed in Santa Fe. Temporary accommodations for the staff were found in the U.S. Courthouse in Santa Fe ("Move Complete," Santa Fe New Mexican, October 9, 1937).

Figure 3.

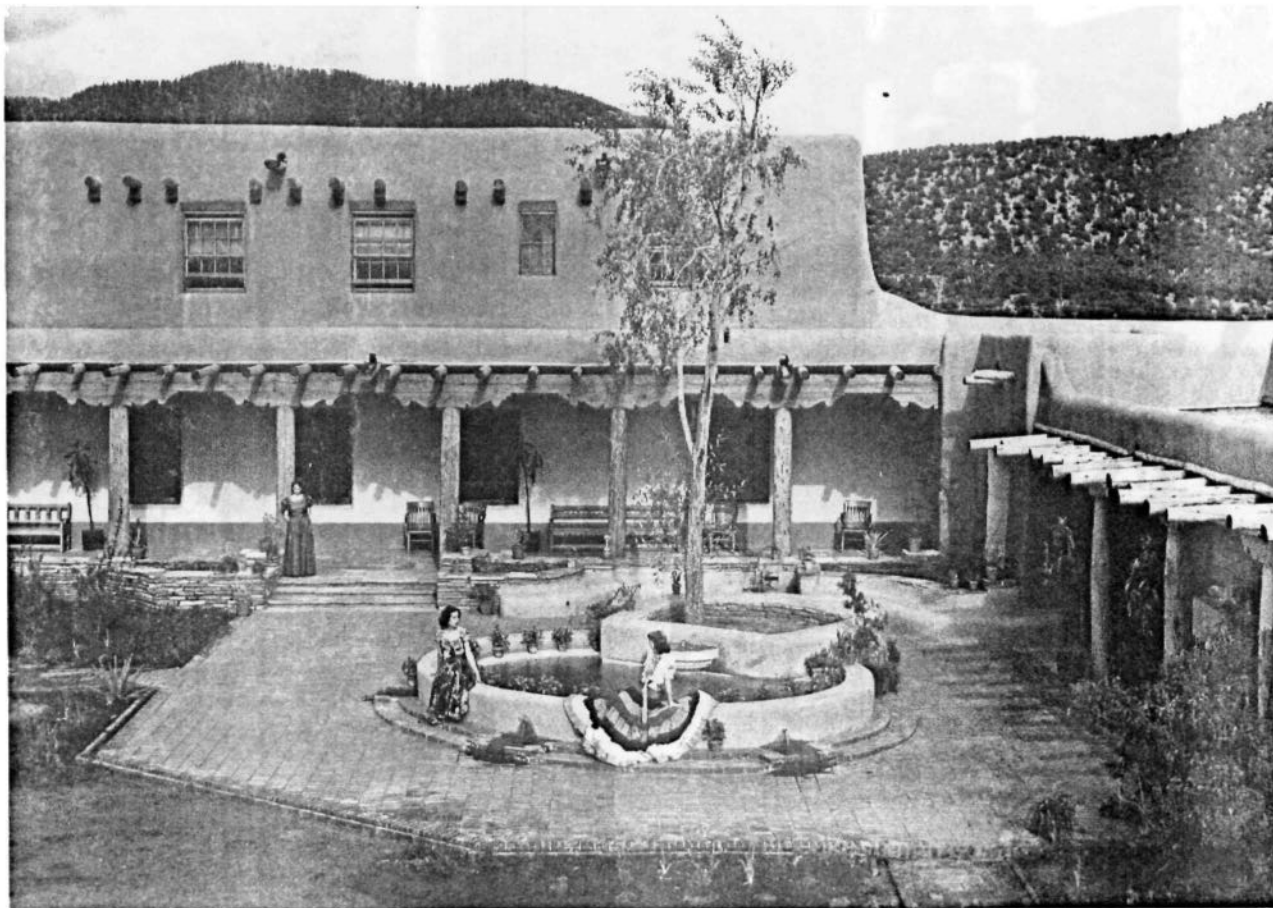

Herbert Maier, who had been with the National Park Service and Region III Director from the beginning of the CCC program, was appointed Acting Regional Director until Assistant Director Hillory A. Tolson of the Washington Office accepted the Region III Director position (Wirth 1980:120), (Figure 2).

On May 11, 1939, Hillory A. Tolson transferred to Santa Fe after 20 years of government service, including Chief of Operations and Attorney for the National Park Service in Washington, D.C. Tolson had supplemented his exceptional education, which included five college degrees, with work in the War Department, the Panama Canal, and the FBI ("Tolson Heads Region Three," Santa Fe New Mexican, May 11, 1939).

- 
- 1 In 1937, National Park Service was organized into four Regions. Region III comprised the states of Arkansas, Oklahoma, Texas, New Mexico, and Arizona. Also included in the Region were the southern portions of Colorado and Utah.
  - 2 Portal: A covered porch or walkway generally bordering a patio.
  - 3 Walker, Carl. Interview by Steven M. Burke, January 24, 1985.



## CHAPTER 1: THE BUILDING AS ORIGINALLY CONSTRUCTED

### General Description

The adobe walls are laid up in a battered configuration (i.e., wider at the base and narrowing toward the top) over foundations of native stone (Figure 4). The stem wall, built of exposed stone, rises to an average height of 2 feet above the ground level. The building's flat roof is supported by two types of framing members: vigas (round posts of debarked pine) which average 8 to 10 inches in diameter<sup>4</sup>; and massive squared-off beams of pine measuring roughly 8 by 12 inches.

Floors throughout are flagstone with mortar laid on a sand or concrete base.

Windows are wood, double hung, with multiple panes and are framed above with heavy rough-cut lintels.<sup>5</sup> Wood doors, in a variety of styles, were handmade on site. The front doors, constructed of two 4-foot wide double paneled doors, were sandblasted and then scraped with saw blades to give a rough appearance (Figure 5).

Records of the original interior finishes could not be located; however, since the completion of the building in 1939, it is assumed that the primary interior colors have not been drastically altered. According to Frank Martinez, GSA maintenance worker, the flagstone floors throughout the building have been treated semi-annually with a varnish floor sealer.<sup>6</sup> The second story floorboards may also have been treated with a sealer. Currently the hardwood floors on the second story and the concrete floors in the offices enclosing the courtyard, which at one time may have been tiled, are carpeted wall to wall.

Walls throughout the building have maintained a similar color to the original "cream",<sup>7</sup> that had been used. Walls are now "beige" with a "chestnut" dado design.<sup>7</sup> All walls, which originally were painted with an oil base paint, are now painted cyclically with a semi-gloss latex paint.

Ceilings throughout the building consist of vigas and beams with decking above. Photographs show that, like the floors, the ceilings were preserved with a "neutral" color varnish.



The following equipment requirement list was located in the Federal Archives Center in Denver, Colorado. It describes last minute interior finish work.

Work contemplated will consist in interior finishing carpenter work, cabinetwork, installation of hinges, locks, etc., on doors, construction and installation of several special doors, installation of 50 light fixtures, laying 1,210 square feet of linoleum and 3,496 square feet of tile flooring, laying 3,000 square feet of flagstone (floors and walks, patio, etc.), some plastering and painting, and minor revision and alteration of various interior details.

ESTIMATE OF COST

1. Bill of Materials: unit and total prices, differentiate between emergency funds and contributions by park authority or sponsor.
2. Skilled Labor: number of hours contemplated, hourly rate and total cost for each type of labor, except CCC.
3. Equipment: rental only -- type, hourly rental, total cost, include operator when necessary.

1. BILL OF MATERIALS:

See attached bill of materials \$\$2,616.99

2. SKILLED LABOR:

Carpenter, 307 hours	@ \$1.125/hr.	\$ 345.38
Tile & Linoleum Worker, 184 hours	@ \$1.25/hr.	230.00
		\$ 575.38

3. EQUIPMENT RENTAL:

Rental of Electric Floor Sander, 60 hours @ \$0.50/hr. 30.00

(No operator expense, to be operated by carpenter)

GRAND TOTAL: \$3,222.37

BILL OF MATERIALSREGIONAL OFFICE HEADQUARTERS BUILDING

- Job 138, Class 120

( Supplemental )

HARDWARE (Doors, Cabinets, etc.):

<u>Hinges:</u>	3 pairs Extra Heavy Ball Bearing Knuckle Butt-Hinges, non-template, 6"x5" open	@ \$6.00/pr.	\$ 18.00
	1½ pairs Extra Heavy Ball Bearing Butt-Hinges, 5"x5"	@ \$3.00/pr.	4.50
<u>Locks:</u>	2 only Cylinder Entrance Door Locks, knobs on both sides, for 4½" doors	@ \$12.00/ea.	24.00
	1 set Knobs and Roses, to match above locks	@ \$4.00/set	4.00
	1 only Extra Heavy Flush Mortise Type Foot Bolt, with strikes for concrete floor	@ \$3.00/ea	3.00
	150 only Cast Iron Door Knobs	@ \$1.00/ea.	150.00
	12 only Wrought Iron Escutcheons	@ \$2.00/ea	24.00

<u>Cabinets: Miscellaneous Cabinet Hardware (Cabinets not yet detailed, complete specifications not available)</u>	Estimated:	50.00
<u>Light Fixtures: Tin, Tubing, Light Cord, and Miscellaneous Materials for 50 Light Fixtures</u>	Estimated:	50.00
<u>LUMBER (CABINETS):</u>		
3000 BM Best & Better Yellow Pine	@\$60.00/M	180.00
<u>FLOORS (Tile &amp; Linoleum):</u>		
<u>Linoleum, 3/16" Medium Battleship:</u>		
Files Room: 720 square feet		
Mails Room: $\frac{490}{1210}$ " "		
	@\$0.16/ft.	193.60
<u>Tile, 1/8", Asphalt Base:</u>		
General Office: 1,566 square feet		
Projects: 670 " "		
Engineering, BPOAD, etc.: $\frac{1,260}{3,496}$ " "		
	@\$0.20/ft.	699.20
<u>PLASTER: 7<math>\frac{3}{4}</math> tons Fibrated Plaster</u>	@\$23.00/ton	178.25
<u>FLAGSTONE FLOORS &amp; WALKS:</u>		
3000 square feet Flagstone	@\$0.01/ft.	\$ 30.00
250 sacks Portland Cement	@\$0.76/sack	190.00
<u>SPECIAL DOORS:</u>		
Lumber for special doors	Estimated:	184.33
<u>MISCELLANEOUS (Interior Finishing, Plumbing, etc.):</u>		
6/4"x16"x16'0" "D" Select (2 pieces)	@\$3.68/ea	7.36
1 gallon Denatured Alcohol	@\$1.25/gal.	1.25



25 pounds No. 1 Steel Wool	@\$0.29/lb.	7.25
2 pieces 2"x4"x16'0" "D" Select	@\$1.26/ea	2.52
4 " 2"x4"x14'0" " "	@\$0.57/ea	2.28
2 " 5/4"x8"x16'0" " "	@\$1.495/ea	2.99
2 " 5/4"x6"x14'0" " "	@\$1.035/ea	2.07
8 " 2"x4"x12'0" " "	@\$0.96/ea	7.68
96 L.Ft. 1/2" Half Round	@\$1.75/c	1.68
2 pieces 4'0"x6'0" - 3/8" Panel Board	@\$2.16/ea	4.32
20 pounds Waterproof Glue	@\$0.50/lb.	10.00
10 " 4d Finishing Nails	@\$0.10/lb	1.00
1 gross 3/4"x8" Round-Head Screws	@\$0.56/gross	.56
100 pounds Burlap	@\$0.05/lb.	5.00
48 L.Ft. 4" Vitrifified Clay Sewer Tile	@\$0.18/ft.	8.64
2 only 4" " " Tees	@\$0.77/ea	1.54
2 " 4" " " 90-degree Long Ells	@\$0.77/ea	1.54
1 " 4" " " " Short Ell	@\$0.80/ea	.80
52 L.Ft. 6" Vitrifified Clay Sewer Tile	@\$0.24/ft.	12.48
1 only 6" " " 90-degree Long Radius	@\$1.00/ea	1.00
1 piece 36"x74" Copper Screen Wire Cloth	@\$2.09/ea	2.09
75 sacks White Atlas Cement	@\$2.98/sack	219.03
Paint and Related Items	Estimated:	31.03
Contingency:		<u>300.00</u>
	TOTAL:	\$2,616.99

#### JUSTIFICATION

This job, as originally approved, provided for the purchase of 140 sacks of cement at 88¢ per sack (\$123.20), other materials amounting to \$256.36, and a contingency fund of \$37.96, making a total of \$417.52 approved for materials. To date 50 sacks of cement have been purchased at a cost of 76¢ per sack (\$38.00), and other materials purchased have amounted to \$371.85, making a total of \$409.85 expended and leaving an available balance of \$7.67. This discrepancy between the estimated cost and the actual cost of the materials is due to the difference between the prices quoted at the time the application was submitted and the prices bid at the time the materials were purchased.

A supplemental approval of \$105.16, to cover purchase of the remaining 90 sacks of cement and of materials for 152 feet of sewer line between the building and the existing camp sewer line, is requested. Plumbing fixtures (lavatory and toilet) were obtained from the Army. No additional man-days are requested, as it is thought that man-days available from the original approval are sufficient to complete the job.

ESTIMATE OF COST

1. Bill of Materials: unit and total prices. Differentiate between emergency funds and contributions by park authority or sponsor.
  2. Skilled Labor: Number of hours contemplated, hourly rate and total cost for each type of labor, except CCG.
  3. Equipment: Rental only--type, hourly rental, total cost, include operator when necessary.
- 
1. For complete Bill of Materials Unit 1 & Bill of Materials for present request see attached sheets.
  2. For skilled labor, number of hours & hourly rate & totals see attached sheets.
  3. No equipment rentals are anticipated during the construction of this structure.

Rough Lumber & Framing

Form Lumber: #2 New Mexico Fir

100 - 2"x4"x12'-0"	800 sq.ft.	¢ 40.00	32.00
100 - 1"x6"x12'-0"	800 " "	¢ "	24.00
50 - 1"x12"x12'-0"	600 " "	¢ "	24.00

Nailing Blocks: Grounds, etc. #4 New Mex. Fir  
 10 - 2"x10"x12'-0" 600 sq. ft. @ 35.00 21.00  
 20 - 2"x4"x18'-0" 320 " " " 10.20

Framing: Studs, Roof construction, etc. #2 N.M.F.  
 2"x4" (18' lengths) 6600 sq. ft.  
 2"x6" " " 3000 " "  
 2"x8" (16' lengths) 500 " "  
 Total 10,100 " " @ 40.00 408.00

Plank: No. 1 common, random widths,  
 1"x8" - 10"-12" Y.P. 1600 sq. ft. @ 60.00 96.00

Shiplap: No. 1, random widths, Y.P.  
 1"x6"-8"-10" 14,000 " " @ 60.00 840.00

Timbers: No. 1 New Mex. Fir  
 24 - 8"x10"x20'-0" 3,200 " "  
 24 - " " " 12'-0" 1,920 " "  
 3 - 10"x12"x16'-0" 480 " "  
 2 - " " " 12'-0" 240 " "  
 5 - 12"x14"x14'-0" 980 " "  
 16 - 12"x12"x12'-0" 2,304 " "  
 Ran. lengths 6"x8" 3,400 " "  
 8"x8" 1,500 " "  
 Total 14,024 " " @ 60.00 841.44

Flooring: N1 White Oak 13/16"  
 2,820 " " @ 95.00 267.90  
 Total 2,564.54

Millwork

Trim: Door & window frames, doors, gates & rails  
 Information Counter, as per detail later  
 No. 1 common yellow pine, S4S  
 4,500 sq. ft. @ 70.00 315.00

Mouldings: 1/2"x1"& 1/2"x2"	1,500 sq. ft.	€ .026	39.00
Doors: White pine, D.S.A. glass (plate in "B")			
"A"	8	@ 12.50	100.00
"B"	1	25.00	25.00
"C"	4	9.50	38.00
All other doors made to detail, see schedule			
Windows: White pine, DSA glass, see schedule			
Sash 54 pair (average)		5.30	286.20
Screens: Stock cypress, 3/4" thick with #14 mesh			
	54	@ 3.00	162.00
Steel Sash: Stock pivoted	6	@ 10.00	60.00
			<u>60.00</u>
	Total		1,025.20 6,126.10

Roofing & Sheet Metal

Roofing paper: 15 lb. felt 432' roll			
	20 rolls	@ 3.35	67.00
30 lb. felt 216' roll			
	156	@ 3.35	526.60
Asphalt: H.M.P. Asphalt	5 T.	@ 55.00	275.00
Flashing: 24 ga. Galv. steel, zinc coated			
	1,700 lb.	@ 7.00	119.00
Water proofing compound:			
	4 - 50 lb. cans	@ 3.60	14.40
Sheathing Paper: Red resin 500' Roll 20 lb.			
	16 rolls	@ 1.10	17.60
Saturated Felt: 15 lbs.			
	5 rolls	@ 3.25	16.25
Insulation Board: 1/2" Standard (Cellotex or equal)			
	8000 sq. ft.	@ 55.00	<u>450.00</u>
	Total		1,485.85 7,611.95

Hardware

Windows:	Spring sash balances, head type			
	4 coils per window 4 to 20 lb.			
	54 windows	@	4.00 set	216.00
	Checkrail locks, 1: window lifts, 1:			
	54 sets	@	1.00	54.00
Doors:	Exterior Doors, cylinder, Masterkeyed			
	Antique Copper 5 sets	@	12.50	62.50
	Exterior Door Hinges 5 "	@	5.00	25.00
	Interior Doors; Locks 36 "	@	3.50	126.00
	" " Hinges 4 "	@	1.25 pr	45.00
	Closed Doors, Hinges 3 1/2"	@	.80	
	" " Locks		1.10	
	16 "	@	1.90	30.40
	Door Stops; 41 Dullbrass	@	1.05	43.05
	Cabinet Hardware, Hinges & Catches			
	6 sets	@	1.50	9.00
	Toilet Door Hinges 2, Locks 1			
	4 sets	@	1.50	6.00
	Paperholders, soap dispensers			
	5 sets	@	3.00	15.00
	Mirrors 5 "	@	2.00	10.00
	Papertowel containers 3	@	1.00	3.00
	Total		644.95	8,256.90

Plumbing

Sanitary Sewer:	6" Vit. Clay pipe 396'	@	.28	110.88
	4" " " 120'-0"	@	.22	26.40
	6" C.I. Soil line			
	232'-0"	@	.50	116.00
	4" C.I. " 108'-0"	@	.44	47.52
	2" C.I. " 90'-0"	@	.24	26.60

Water Lines:	4" steel	300'-0"	@	1.25	375.00
	2" "	260'-0"	@	.30	78.00
	1 1/2" "	115'-0"	@	.20	23.00
	1" "	155'-0"	@	.15	23.25
	3/4"	60'-0"	@	.10	6.00
	1/2"	20'-0"	@	.09	1.80
Fixtures:	Water closets, wash down fixture complete				
	5 w.c.		@	21.00	105.00
	Lavatories, 17"x21" Vit. China				
	4 L		@	19.00	76.00
	Urinals, Stall type Enam. Iron				
	1 U		@	22.00	22.00
	Floor drains, Brass, 2"				
	2		@	5.00	10.00
	Floor drains, Brass, 4"				
	1		@	6.00	6.00
Note:	Fittings, Bends, traps, etc. included in cost per ft. of pipe lines				
Manhole construction					50.00
Calking & Packing material					40.00
Total					1,143.45 9,400.35

Miscellaneous

Standard Malleable washers 1/2", 5/8"x3/4"				
	66 lbs.	@	15.00	10.00
Lag bolts: 1/4" to 5/8" assorted				
	100 "	@	10.00	10.00

Bolts: Machine 1/2" to 3/4" 4" to 24" long assorted	500 "	@ 15.00	75.00
Wi 18 ga. annealed 4 - 25 lb. coils		@ 2.40	9.60
Nails: 4 to 8 d Smooth box	700 "	@ 5.50	38.50
6 to 8 d Finishing	300 "	@ 6.00	18.00
8 to 20 d Common	1200 "	@ 5.50	66.00
Flue lining: Vit. Clay 24"x24" Inside diam.			
30'-0"		@ 3.00	90.00
" 8 1/2"x8 1/2"		@ .45	4.50
10'-0"			
Creosote Stain:	3 gal.	@ 2.50	7.50
Lead & Oil paint	10 "	@ 3.00	30.00

Item for consideration of price increases  
Misc. Items not considered in present plans  
& materials list.

500.00

Skilled Labor	Total	1,190.10	10,590.45
Plumber	300 hrs. at L 1.25		375.00
Electrician	200 " " 1.25		250.00
Skilled Carpenter	745 " " 1.00		<u>745.00</u>
	Total	1,370.00	11,960.45

Electrical

2 - 100 amp. fuses @ 50	1.00	
10 lbs. solder @ 50¢	5.00	
5 rolls rubber tape @ 30¢	1.50	
80 - 4" oct plaster rings @ 10¢	8.00	
30 - 4 " sq. boxes @ 15¢	4.50	
42 deep switch boxes @ 12¢	5.04	
500 ft. 3/4" tubing @ 9¢	45.00	
50 - 3/4" couplings @ 9¢	4.50	
100 - 3/4" connectors @ 10¢	10.00	
2000 ft. #12 wire @ 2¢	40.00	
40 single switches @ 35¢	14.00	
6 - 2 gang plates @ 30¢	1.80	
8 - 3 way switches @ 40¢	3.20	
10 - rolls friction tape @ 25¢	2.50	
80 - 4" oct boxes @ 15¢	12.00	
80 angle hangers @ 15¢	12.00	
30 - 4" sq. single covers @ 12¢	3.60	
1500 ft. 1/2" tubing @ 8¢	120.00	
200 - 1/2" couplings @ 6¢	12.00	
200 - 1/2" connectors @ 6¢	12.00	
4000 ft. #14 wire @ 15¢	60.00	
60 receptacles and plates @ 25¢	21.00	
3 - 3 gang plates @ 50¢	1.50	
40 single switch plates @ 15¢	6.00	
1 - 16 circuit panel flush	25.00	
1 - 100 amp. switch flush	20.00	
16 plug fuses @ 5¢	.80	
50 ft. 1 1/4" tubing @ 20¢	10.00	
150 ft. #1 wire @ 12¢	18.00	
5 - 1 1/4" couplings @ 70¢	3.50	
4 - 1 1/4" connectors @ 70¢	2.80	
300 ft. underground cable @ .30	90.00	12,536.69

Grand Total for Unit #1  
exclusive of heating

12,536.69



MATERIAL LIST  
SP-1 New Mexico - Tenth Period Only

Materials, for which no materials cost is included  
 in the above material breakdown:

Gravel: 220 cu. yds.  
 Sand: 230 " "  
 Masonry: 260 " "

This material furnished by local participation

Adobe: 42,000 brick - Local CCC camp SP-1, N.M. are making  
 on the job.

Logs: Vigas etc 4,200 ft. at approx. .05 per ft.

220.00 are being furnished by the U. S. Forest Service with-  
 out material cost.

Mandays for making the above material available are included  
 in the total manday request.

Note: This material is a part of total material list for  
 Unit one, see complete list following.

Adobe: 18,500 brick at 15.00 M	277.50
Pipe: 320' of 3/4" G.I. at 8.19	26.21
Fittings for above pipe	2.80
Garden hose: 3/4" black 100' @ .066	6.60
15 lb. roofing felt 10 rolls at 3.35	33.50
Straw: 3 bales @ .50	<u>1.50</u>
Total	348.11

Cement: 600 sacks @ .90	540.00
Lumber: Shiplap #2 Y.P. 600 ft. @ 55.00	33.00
2"x4" 300 42.00	12.60
Form lumber #4 N.M. Fir 40.00 1000	40.00
Soil line: Cast Iron 6" with fittings	
110-0" @ .50	55.00
4" Cast Iron 108'0" @ .44	47.52
2" " 20'0" .24	4.80
Galv. Steel Pipe: 2" 260'-0" @ .30	78.00
" " " 1 1/2" 115'-0" @ .20	23.00
Miscellaneous; Sandcreens, tape lines, chalk lines, etc.	55.68
Nails: 6 to 20d common 400 lb @ 5.50	20.00
Skilled Labor:	
Plumber 200 hrs. at 1.25	250.00
Electrician 100 hrs. at 1.25	125.00
Skilled Carpenter 755 hrs. @ 1.00	755.00
Total Skilled Labor	1,120.00
Total Materials	1,263.71
The following materials will be purchased from funds allotted by the Public Works Administration for the purchase of land and materials.	<u>2,383.71</u>

Steel	200 lbs. bars @ 6.00	120.00
Mesh:	6-6x10-10 Elec. welded 7000 sq.ft. @ .25yd.	154.00
Cement:	450 sacks @ .90	405.00
Rough Lumber:	#4 N.M.Fir 2,220 ft. @ 40.00	88.80
Finish "	#1 Yellow Pine 4,500 ft. @ 70.00	315.00
Felt:	saturated 5 rolls @ 3.25	16.25
Waterproofing compound:	4.- 50 lb. cans @ 3.60	14.40
Nails:	500 lbs. @ 5.50	27.50
Waterline:	4" galv. steel 300 ft. @ 1.25	375.00
Electric conduit & roughing in fittings		
	<b>Total</b>	<b>200.00</b>

Floor drains:	Brass 2" 2 @ 5.00	10.00
"	" " 4" 1 @ 6.00	6.00

Timbers:	See timber list	
	4000 sq. ft. @ 60.00	<u>240.00</u>

1,971.95

## Description of the Building Exterior

### Entrances

The main entrance to the National Park Service building is located on the north side of the structure overlooking the Old Santa Fe Trail. The two-story entrance has a symmetrical motif: a large door is centered in the adobe wall and is flanked by massive buttresses of adobe laid up in sculptured, irregular forms. A 12-light window with 9-inch by 9-inch panes is set in above the door, with a rough-cut lintel slightly offset to the east. The walls at this portion of the building have a thickness of 4 feet 9 inches at their base. As shown on the plan (Figure 6), the stone stem walls are exposed to a height of approximately 2 feet.

An entrance on the building's west side is used primarily by those employees who park in the west lot. The building is entered through a small unused patio, through an enclosed corridor just off the Division of Maintenance and into the interior patio.

In 1970, a window was removed and a wall cut to make way for an entrance to Room 128. Westley Volney, Landscape Architect, designed the new opening which was used by employees working in a temporary trailer on the building's south side. A concrete slab was poured and a porch-like structure built. Pumice block finished with stucco, posts of debarked pine, corbels, canales and vigas were the primary materials used. The date of this alteration is not definitively known (Figure 7).

Employees may also enter the building from the east entrance which is directly off of the main parking lot. This entrance leads through a corridor, past the conference room, and into the main foyer.

### Roof

Roof and parapet drawings show details of parapet construction, flashing techniques, and moisture protection. Many of the building's parapets extend up to 2-1/2 feet above the roof line. Once the adobe bricks were laid, metal lath was attached to the wall providing a rough surface for a 1-inch layer of cement stucco. Roof construction consisted of 1/2-inch insulation board over wood decking, with six layers of flashing protruding through the parapet. Up to

four layers of 32-inch, 15-pound felt were applied above the flashing which made way for the final application of tar and gravel (Figure 8).

#### Columns, Vigas and Corbels

The log portal columns surrounding the patio are attached to rubble masonry footings with a 1-inch by 10-inch dowel used to attach the column to its base. As originally constructed, the column bases were grouted to prevent rotting after the final flagstone was laid (Figure 9).

All wooden members (e.g., viga ends, joists, bearing plates and nailing blocks) touching or embedded in the adobe, concrete, or masonry were treated with a preservative called pentachlorophenyl. They were then waterproofed and wrapped in felt. All vigas that projected beyond the wall line were cut from a 5-foot to a 3-foot projection.

Corbels are used in a number of places throughout the building. Many of the hand-carved corbels are attached to a 10-inch wood beam using 5/8-inch lag screws. A typical corbel dimension used in the building's foyer is 10 inches by 12 inches by 50 inches (Figure 10).

The following job application form, found in the Federal Archives in Denver, describes the justification for cutting and hauling logs for the building.

#### JUSTIFICATION

660 man-days are requested for expenditure in cutting and hauling 399 logs and ~~1005 poles~~ from the Santa Fe National Forest. Of these, 145 logs are for use in construction of Unit II of the Regional Office Headquarters Building, and 245 logs and ~~1005 poles~~ will be turned over to Tucumcari Metropolitan State Park, SP-7 New Mexico, for use in construction of the bathhouse and other structures in that park.

The logs are located at the head of the Rito Torrito in the Santa Fe National Forest, approximately 54 miles from Santa Fe, (and it is planned to establish a side camp there) to cut

and haul the logs while present mild weather and passable road conditions permit.

Man-days for this job are available on the camp Work Program Outline from Classification 120, Other Buildings.

EQUIPMENT REQUIREMENTS: All necessary equipment available.

SPECIFICATIONS: Logs and poles will be cut from timber selected by Forest Service, cut to specified lengths, trimmed, and hauled to Camp SP-1-N for distribution as needed.

ESTIMATE OF COST:

Bill of Materials: None

Skilled Labor: None

Equipment Rental: None

\* Detachment of enrollees from SP-1 will be quartered at Forest Service Camp F-53-N, Glorieta, New Mexico

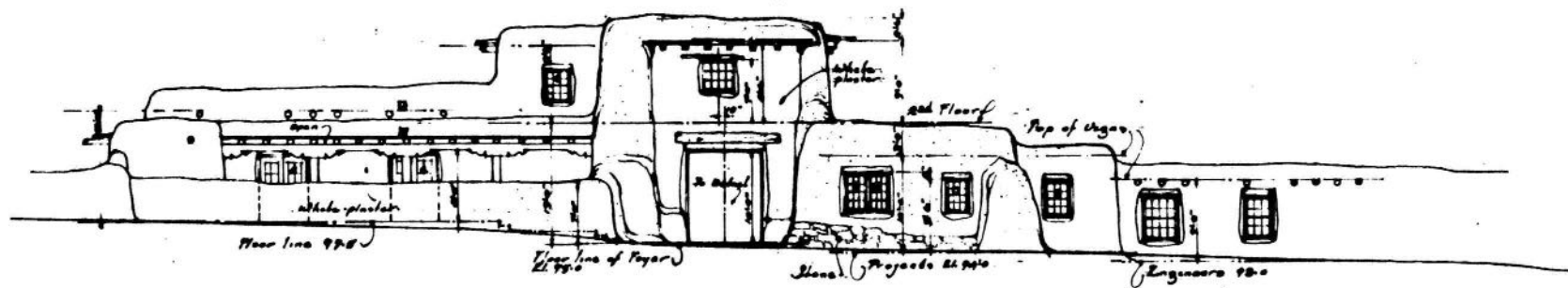

NORTH ELEVATION REVISED  
 Entrance Motif Revised Feb. 18, 1930  
 Scale 1/8" = 1'-0"

UNITED STATES DEPARTMENT OF THE INTERIOR NATIONAL PARK SERVICE <small>Cooperating with</small> NEW MEXICO STATE PARK COMM.	
SANTA FE HYDE S.P. REGIONAL HEADQUARTERS BLDG. <small>REVISION OF PLAN OF 1928</small> <small>Approved 11-13-1927.</small>	50-1-NM 2-18-30 2-18-30 2-18-30
Drawn by: <i>[Signature]</i> Revised by: <i>[Signature]</i> Approved: <i>[Signature]</i>	2-18-30 2-18-30 2-18-30

Figure 6.

Elevation showing the final entrance motif and exposed stone foundation.

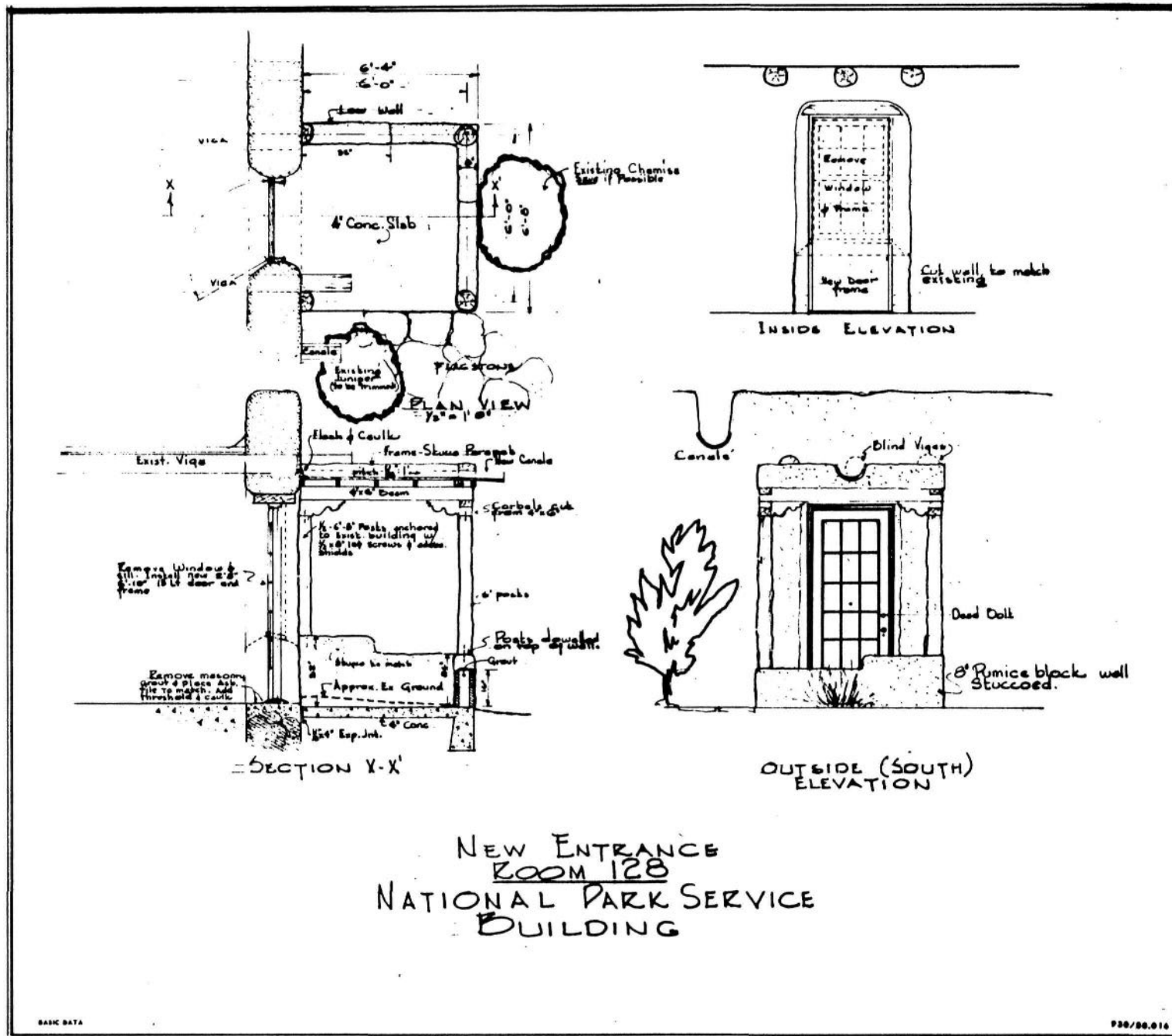
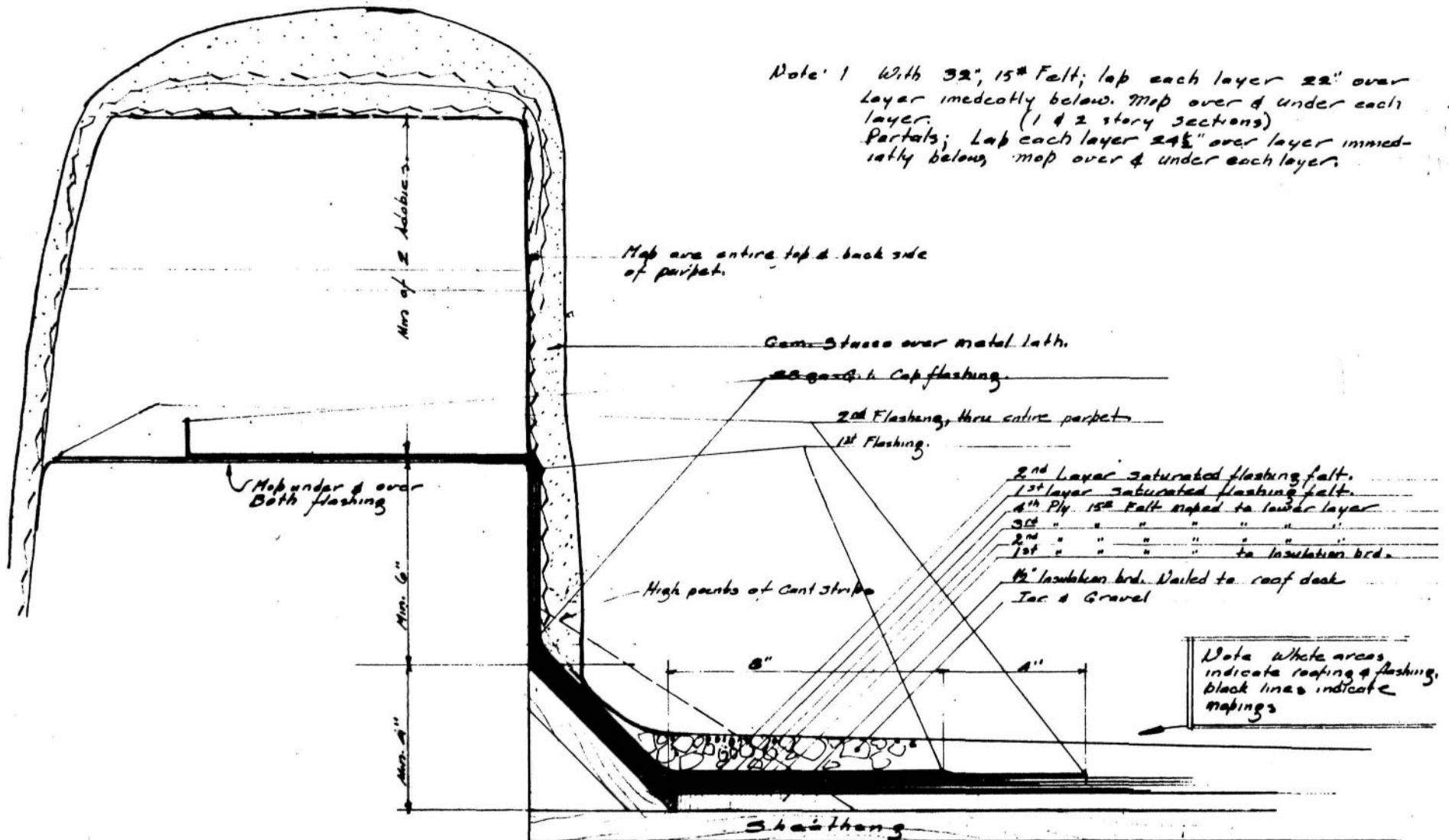

Figure 7.

A new entrance to Room 128 was added to the south side of the building by removing a window and cutting the wall.





**Roof & Flashing Detail**  
Reg. Headquarters Bldg.  
1/2 full sec. 3-31-38 J.S.

- Note 1 This detail applies to all one story sections except Parapets.
- 2 Parapets; omit insulation board & 1st layer of 15" roofing; substitute 1 layer of sheathing paper, lapped 1" for 1st layer of 15" felt on parapets.
- 3 Omit 1/2" insul brd. & substitute sheathing paper to 2nd story roof area. 4" bats of rock wool to be used in roof construction over 2nd story roof.

Figure 8.

Roof and flashing details showing roof and parapet construction techniques and materials.

## Outbuildings

### Service Building

Separate from the main building, on the south side, a service building was built complete with a shop, garage and incinerator. North and east elevations were constructed of vertical logs. A metal lath strip was attached between each log so cement plaster chinking could be applied. The height of each log measures 8 feet with a diameter of approximately 7 inches. A 7-inch viga, acting as a lintel above, was doweled to each vertical log.

### Greenhouse

The original greenhouse was constructed in October 1940, one year after the building was constructed. It faced south with its north side attached to the adobe wall of the building. The 9-foot by 30-foot structure was built of 4-inch by 4-inch wood posts set into a 3-foot high wall of plastered brick, and was used to pot and store plants for the winter. Generally geraniums and flowers were potted in the greenhouse and brought out into the large patio in the summer. Fixed glazing on three sides and the roof incorporated metal mullions. (The glass specified on the plan was DS "B" quality which, at the time of construction, could be purchased for \$1.03 per pane.) Vents were located at the top of the greenhouse. The entrance (a wood door with 10 lights) was at the east, and benches for plants were built on the remaining three sides. The structure also included a sink. Heat was provided by either a gas water boiler or a steam radiator and 100-watt electric bulbs. The 1940 structure is shown on Figure 11. A smaller more efficient replacement greenhouse was built in 1966 in the same location as the original (Chapter 5).

## Description of the Building Interior

### Layout of the Structure

As mentioned earlier in the text, like many Spanish-Pueblo buildings, the Region III building was constructed around a large open patio. Surrounding the patio were offices occupied by engineers, architects, and geologists, just to name a few. The mail room, general files, general office, and a supply room were grouped around a smaller open patio near the east end of the building. The conference room, also located on the first floor, was enclosed by a small,

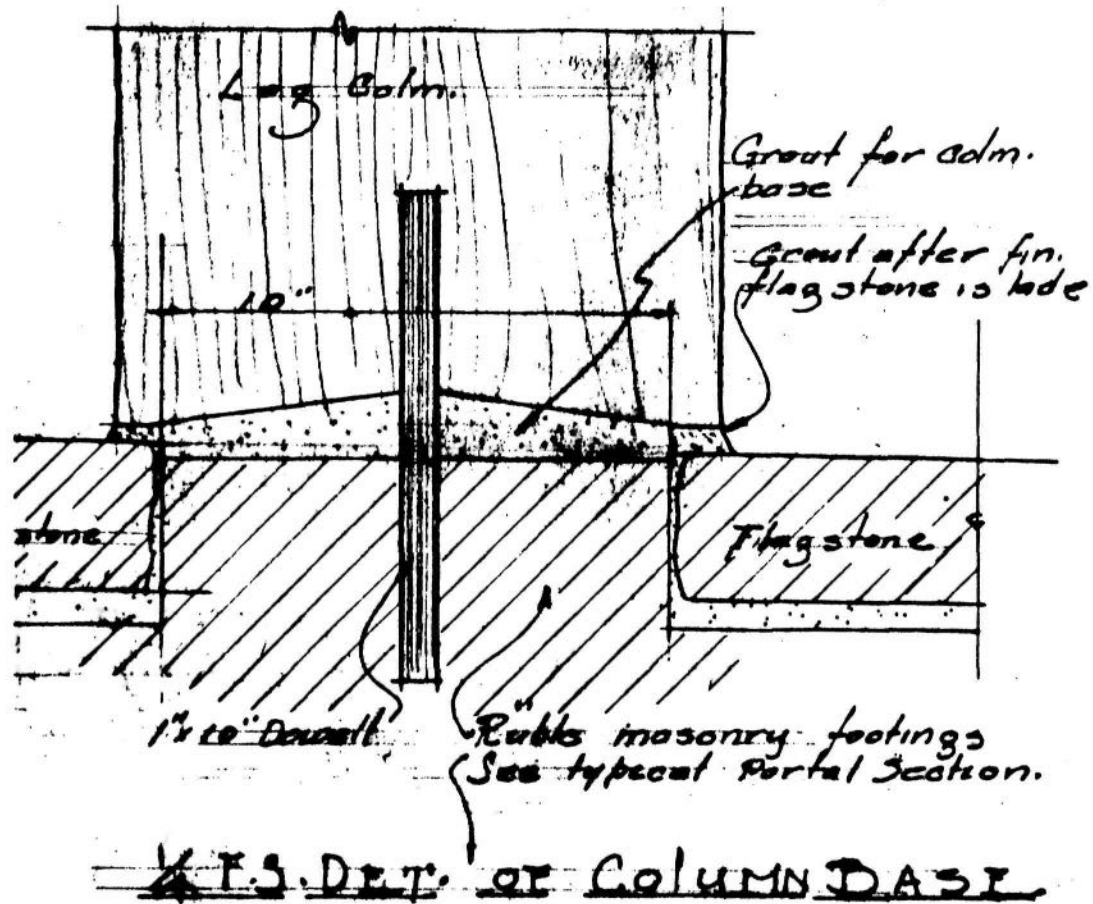

Figure 9.

Detail column base showing how a 10-inch dowel was used to attach the column to its base.

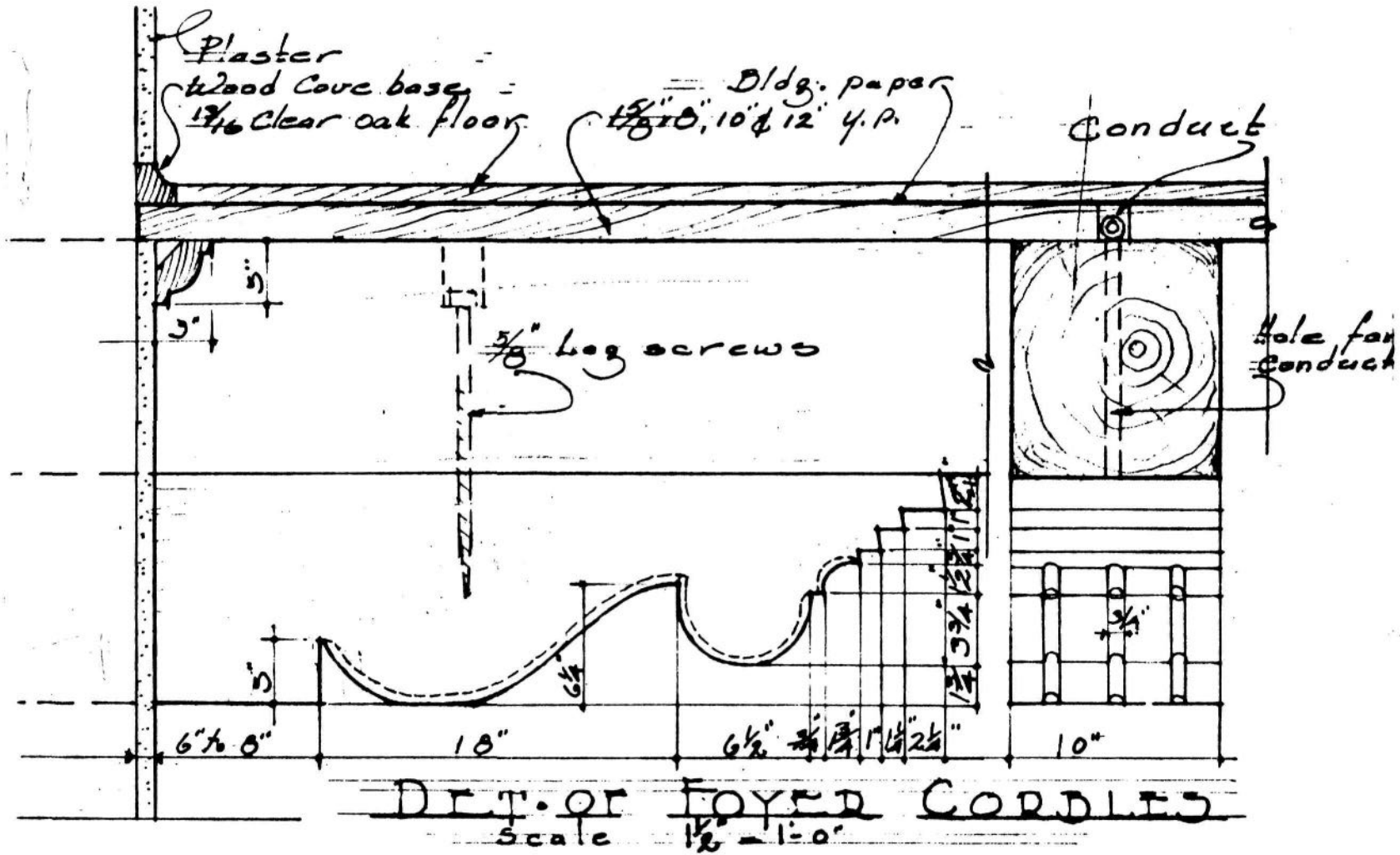

Figure 10.

Many corbels throughout the building reflect the style and design as seen in the foyer.

beautifully landscaped courtyard on the northeast corner of the building. The second floor has always been occupied by the Region's executive officers. This portion of the building is much smaller in scale than the rest of the building. (Refer to Evolution of Spaces drawings in Appendix A, Figures 55, 56 and 57).)

#### Doors and Windows

The headquarters building displays a wide variety of door and window types, most of which were constructed on site of either fir or white pine. One unique door, a Dutch door leading into the files room, was built of 2-ply, 7/8-inch random width shiplap. The two plies of shiplap were attached with hot glue and then connected with machine bolts. A shelf on the lower door projected 11 inches and stood 3 feet 4 inches above the floor. This shelf was later removed. Four butt hinges measuring 2-3/4 inches by 6 inches were made to attach the door to the frame. The Dutch door, still in place, is currently locked and rarely used (Figure 12).

The door from the foyer to the patio displays some unique characteristics. The door is 4 feet wide by 7 feet 6 inches high and has a top panel of carved spindles with double strength glazing between. All the stiles and rails for this door were cut from 2-1/2-inch stock (Figure 13).

All window sashes, double hung with check rails (window stops), were built of standard stock and sizes. Many of the casements have rabbeted meeting rails, and were built out of white pine and glazed with DS "A" glass. Basement windows were constructed of a pivoted type steel casement (Figure 14).

#### Ceiling Construction

The ceilings throughout the building show a variety of construction techniques and styles evident in Spanish-Pueblo architecture. Ceilings in the east drafting room, and the offices bordering the patio, have exposed vigas ranging from 8 inches to 10 inches in diameter. The current drafting room on the west side of the building has 8 to 10 inch unexposed vigas, 2 feet on center. Under each viga is blocking, to which is attached a ceiling made of 1/2 inch smooth surface insulation board. The east drafting room was originally located just east of the present drafting room and is currently used as a personnel office (Figure 15).

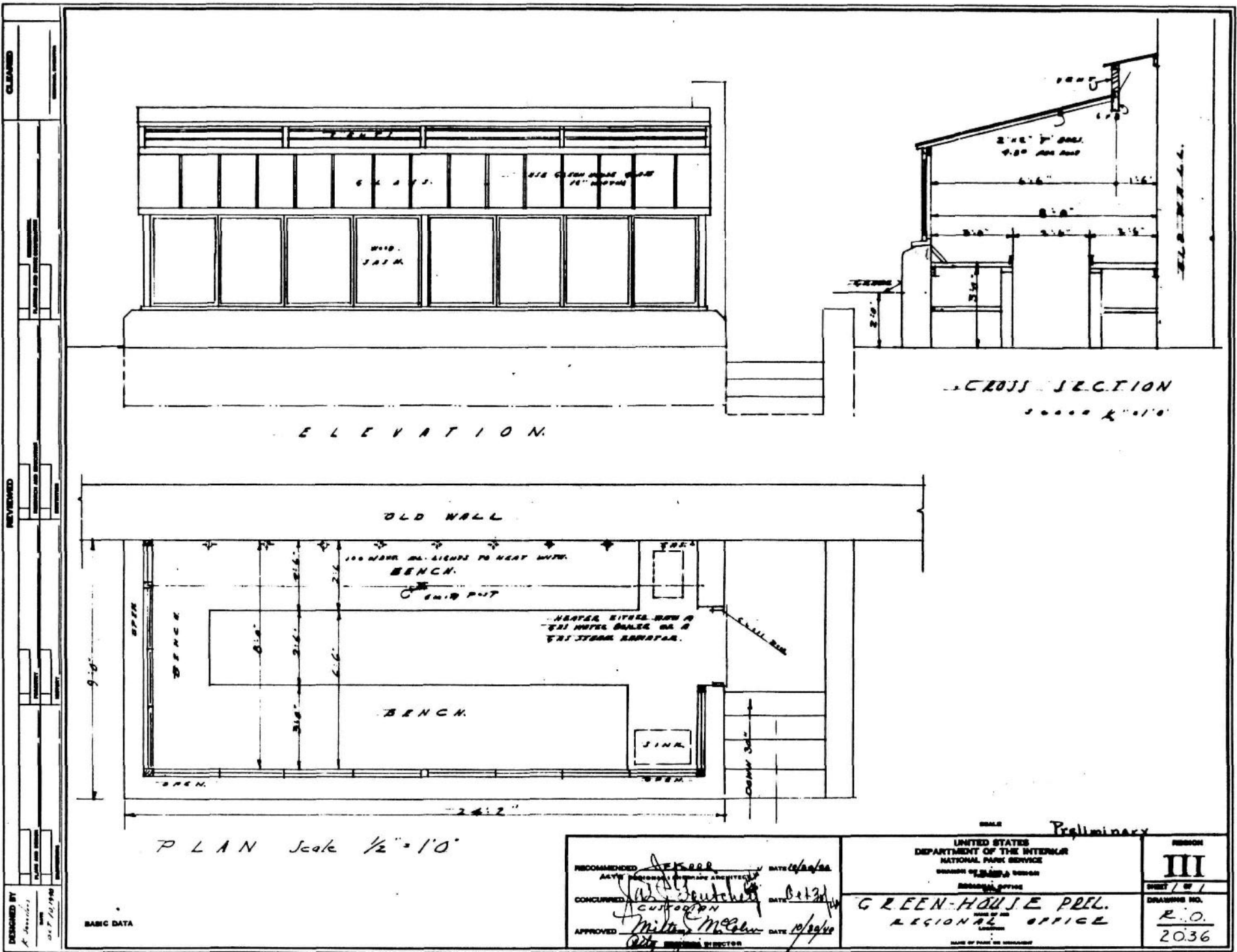

Figure 11. Preliminary details showing the greenhouse as originally constructed in 1940.

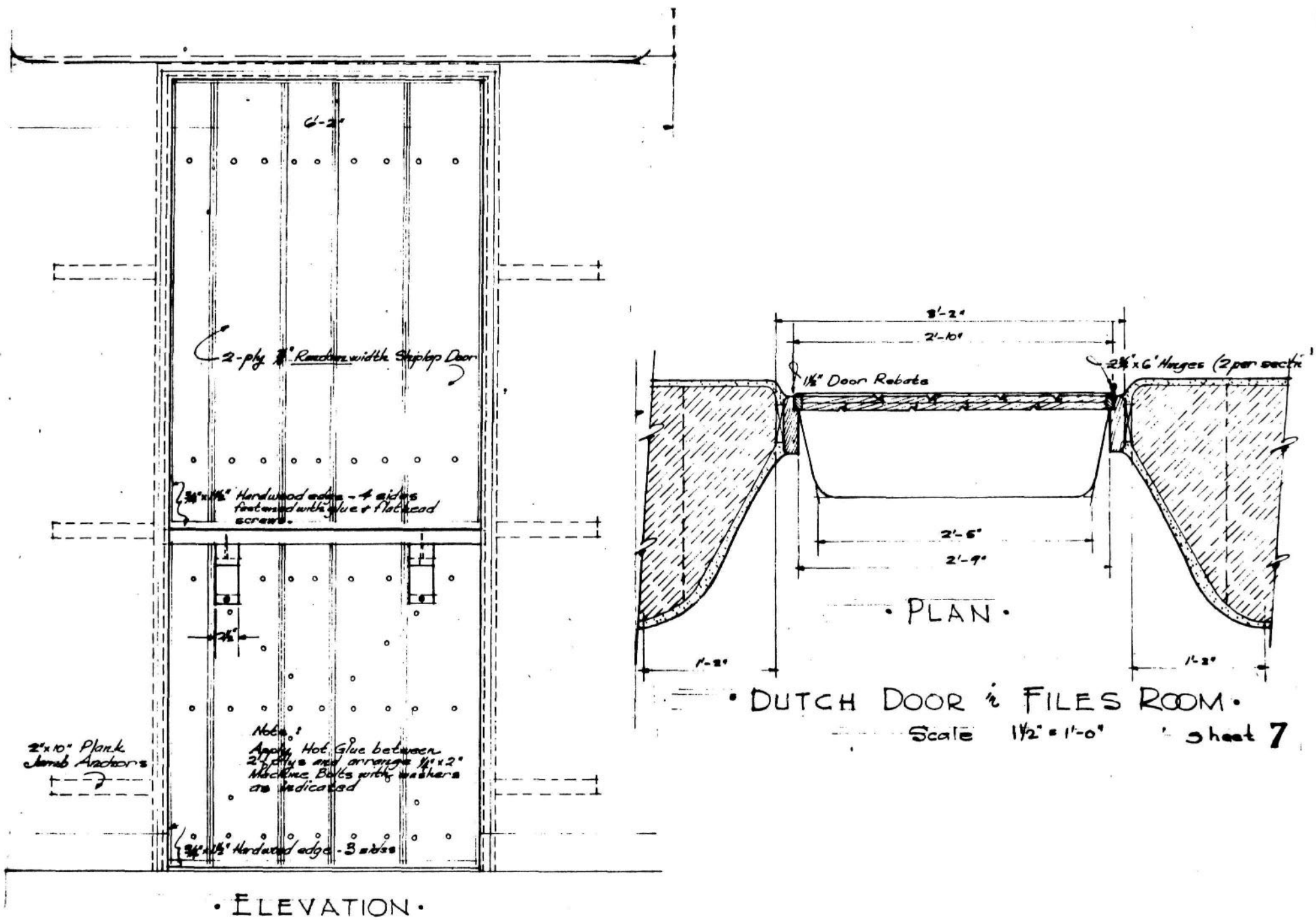
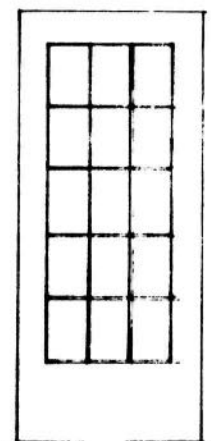

Figure 12.

A Dutch style door, built on the job for the files room, now stands locked and rarely used.







- D- 3'-0" x 7'-0" x 1 3/8"
  - E- 2'-5" x 7'-0" x 1 3/8"
  - F- 2'-6" x 7'-0" x 1 3/8"
  - G- 2'-0" x 6'-5" x 1 3/8"
  - H- 3'-0" x 7'-0" x 2 1/8"
- Doors to be 3 ply.  
Fir or white pine.

- A 3'-0" x 7'-0" x 1 3/8" white pine
  - B 4'-0" x 7'-0" x 2 1/4" 15 lite W.P.
  - C 2'-6" x 7'-0" x 1 3/8" W.P.
- Note: All doors DSA Glass except "B" which is Barata plate.

DOOR SCHEDULE

All doors except A, B, C, to be detailed & made & made on the job.

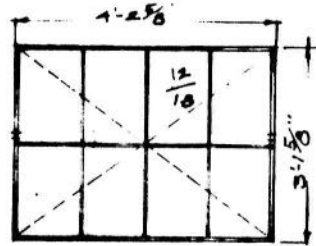
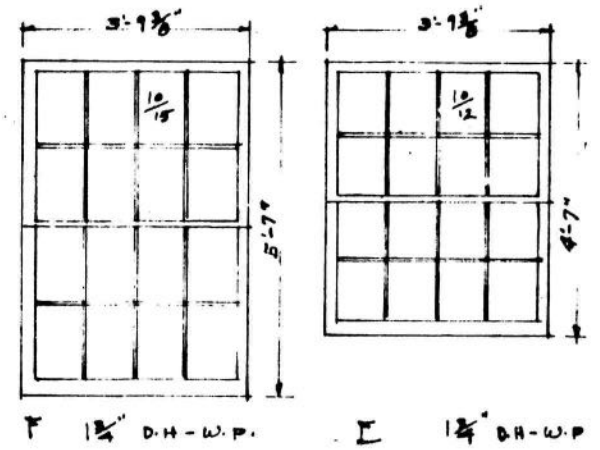
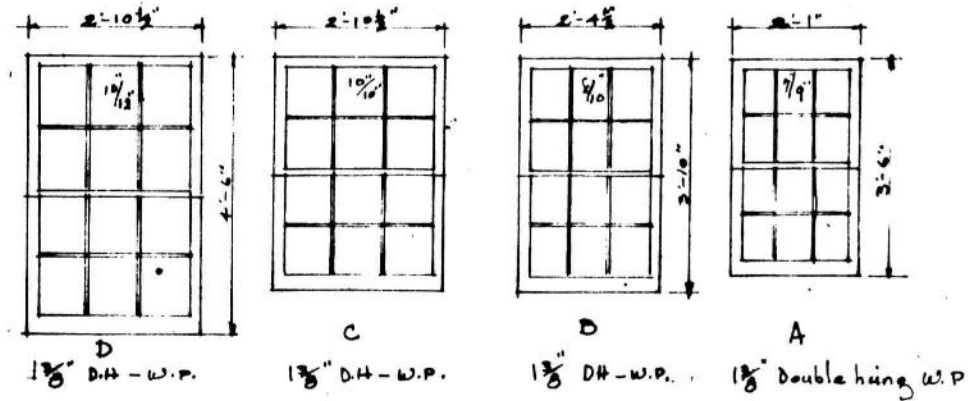

J Steel sash - Pivoted - BASEMENT

WINDOW SCHEDULE  
All sash except as noted to be stock sizes, stock design, Double hung to have check rail, Casements to have rabbet meeting rail. All sash to be white pine, glazed with DSA Glass except as noted.

Figure 14.

Door and window schedules show all windows as double hung with check rails. Both window frames and doors were constructed of white pine.

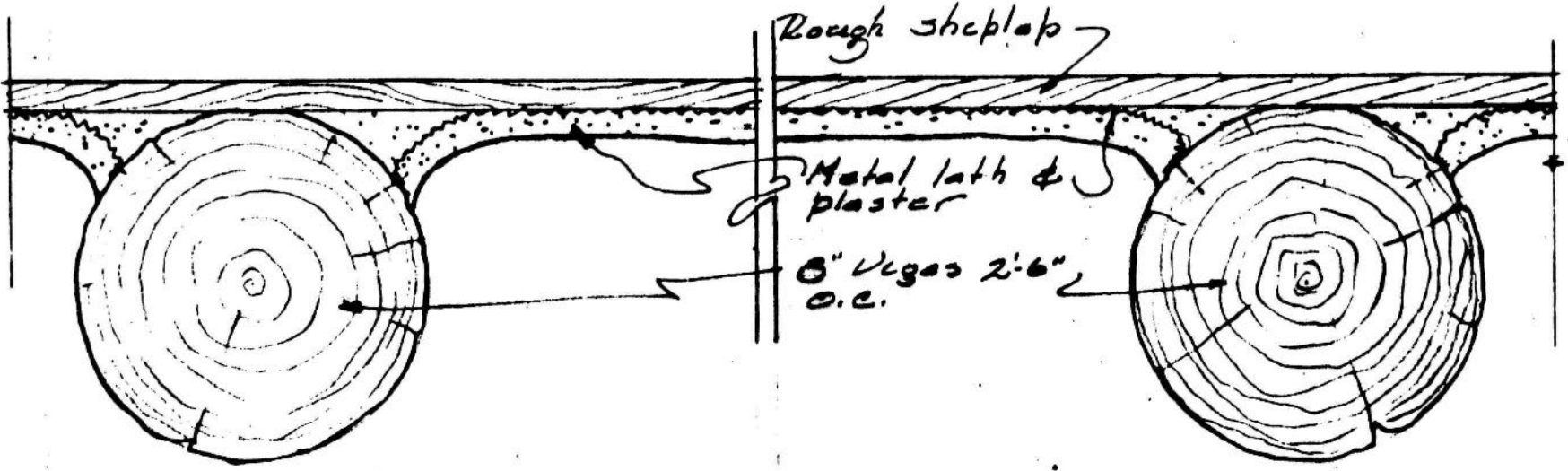

1/2 F.S.D. CEILING TO EAST DRAFTING R.M.

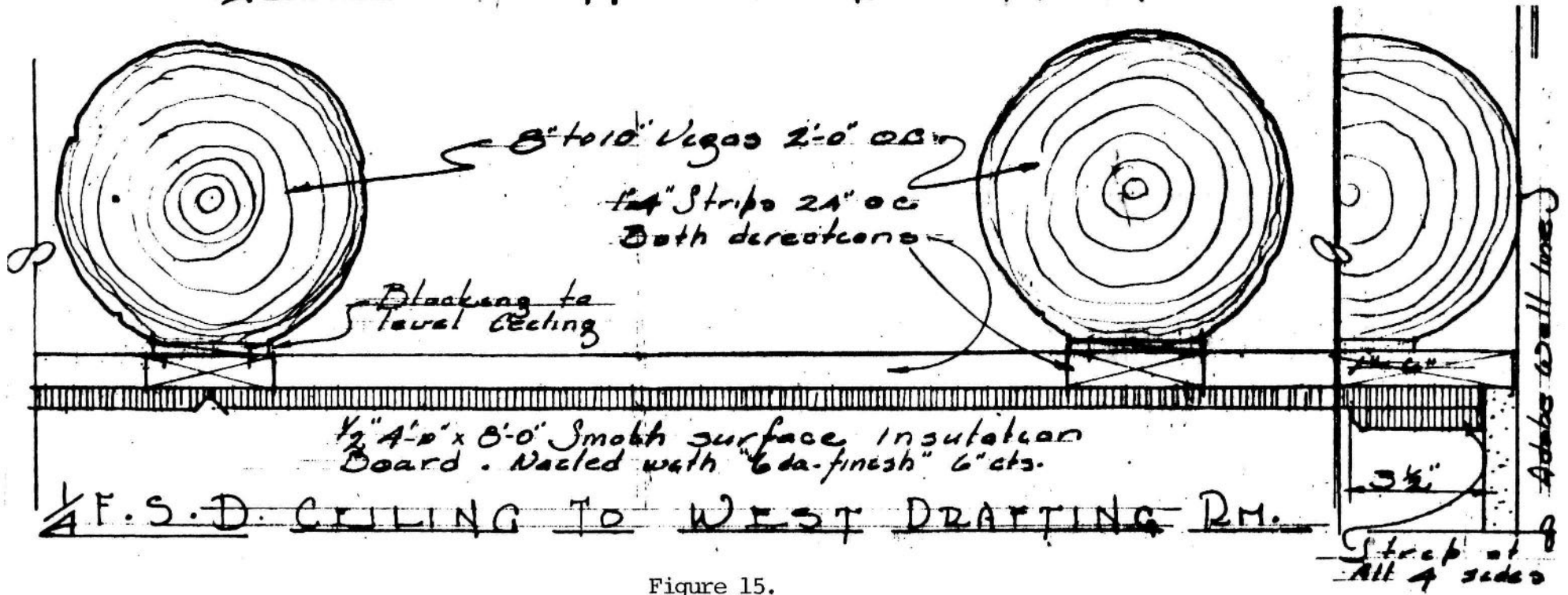

1/4 F.S.D. CEILING TO WEST DRAFTING R.M.

Figure 15.

Ceiling construction details in the east and west drafting rooms. Various ceiling treatments are seen throughout the building.

### The Entry Foyer and Stairs

The north entrance foyer is a space approximately 18 feet by 33 feet with a ceiling height of 10 feet 1 inch. Like many of the floors in the building, the foyer floor was constructed of flagstone laid in cement mortar and finished with a varnish sealer. Beams measuring approximately 10 inches by 12 inches span the foyer ceiling. There are doors in two of the foyer's three openings. The main entry is a wooden double door, each leaf measuring 3 feet 1-5/8 inches by 5 feet 4-5/8 inches and having 12 hand-carved panels. The doors are attached to the frame by six handmade 6-inch by 6-inch ball-bearing butt hinges.

In an opening on the foyer's east wall, two steps lead up to a wide hallway where the stairs to the second level are located. As originally constructed, the stairs were made of 12-inch logs (with 17-inch logs on the two bottom treads), each log halved and adzed smooth (Figure 16).<sup>10</sup> The logs extended 10 inches into the adobe walls and were then doweled and caulked. These stairs were later extensively modified (Chapter 4).

### The Regional Director's Office

Since the building was opened in 1939, a number of Regional Directors from Herbert Maier and Hilory Tolson to Robert Kerr, current Regional Director, have occupied the same office. Located on the north side of the building, the office measures 23 feet 6 inches long by 18 feet wide. It came complete with a fireplace, one of four on the second floor. All fireplaces were built on concrete slabs, and so that they would be identical, the openings were constructed from templates. Designed in the traditional "behive" shape, the fireplaces were constructed of fire brick, covered with cement plaster, and whitewashed. Each fireplace has a 2-foot 6-inch opening, with chimney breasts battered up to the ceiling (Figure 17).



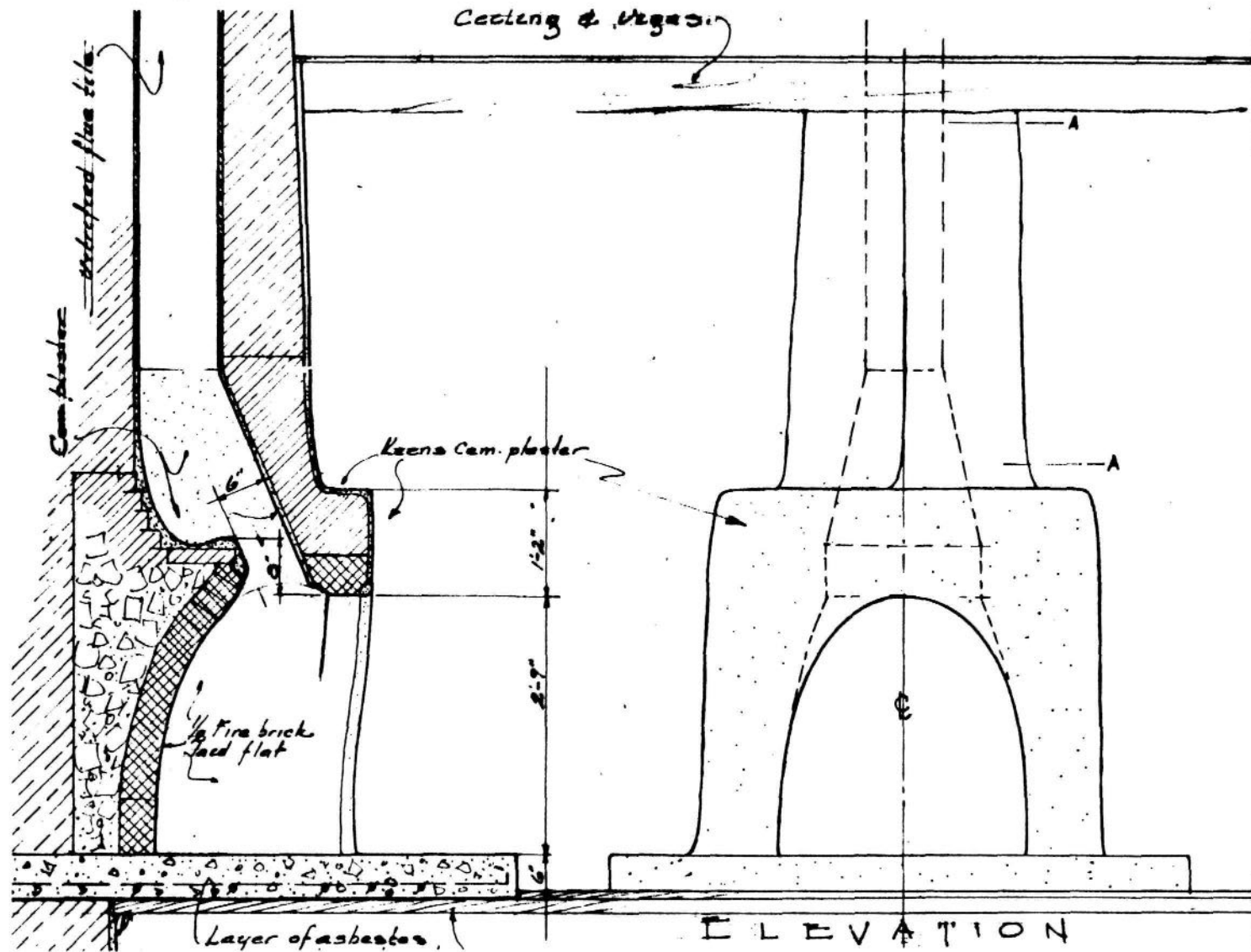

Figure 17.

A typical "beehive" fireplace with a battered chimney seen in the second floor offices.

## Electrical, Heating and Sewer System

### Electrical

The electrical layout plans of 1938 show that the junction boxes and safety switches are placed throughout the building, with the primary controls in the closet under the main staircase. Switches were placed inside of the door openings, 4 feet 6 inches above the floor, and every room was to have at least eight electrical outlets (two on each wall). Other panel boxes are located in the lunchroom basement, the forestry lab (now Concessions), and the drafting room.

### Heating

The original boiler was gas-fired, made of sectional steel, and was complete with an automatic control. The boiler was large enough to supply radiation throughout the building. Steam heated radiators were either free standing or incorporated into the walls (under a window or behind a wall as in the information counter, Figure 18). All steam mains and hot water lines were run in two pipe tunnels at a slope of 1 inch in every 20 feet. The pipe tunnels still run under the building, one about 45 feet north from the boiler room and the other under the east portal of the large patio. The lines were suspended free of end walls and insulated. Air traps and value drains were installed at the end of each return line. Steam and return vents were of black iron (Figure 19).

The original hot water heater was gas-fired and fully automatic, with a rate of 75 gallons of recovery per hour. The pressure tank was located in the east basement next to the water heater and boiler. All the original systems are still functioning; however, in November 1980 the boilers were replaced and in 1983 new heater units were installed in each room (Figure 20).

### Sewer

The building's original sewer system is directly tied into the city sewer system located on Old Santa Fe Trail some 350 feet away from the building. The tile line from the building to the road was installed in 1938 at a cost of \$1,237.25.

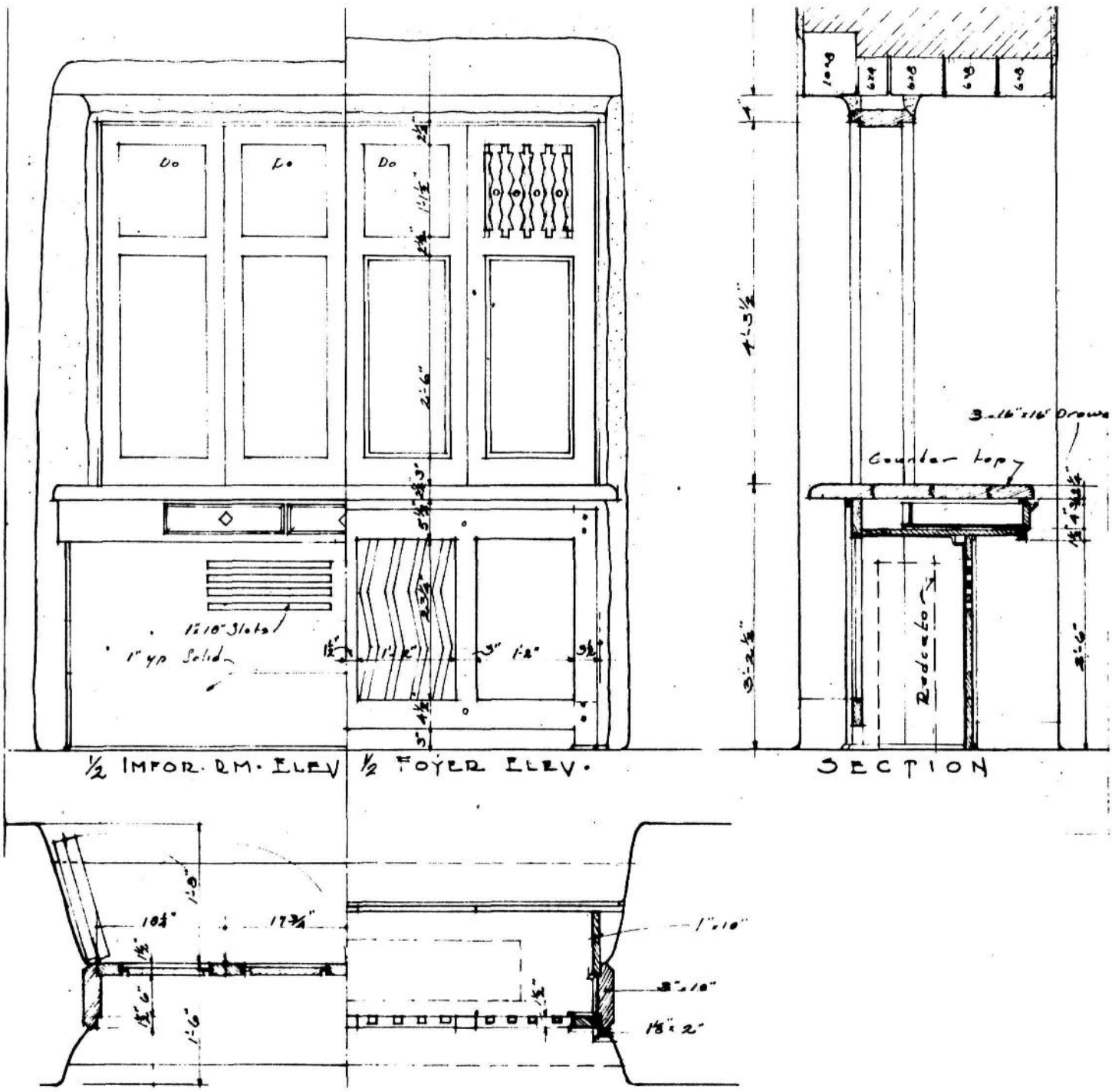

Figure 18.

Radiators from steam heat were often incorporated into the walls as shown here under the information counter.

## PIPE TUNNELS 1/8"=1'-0"

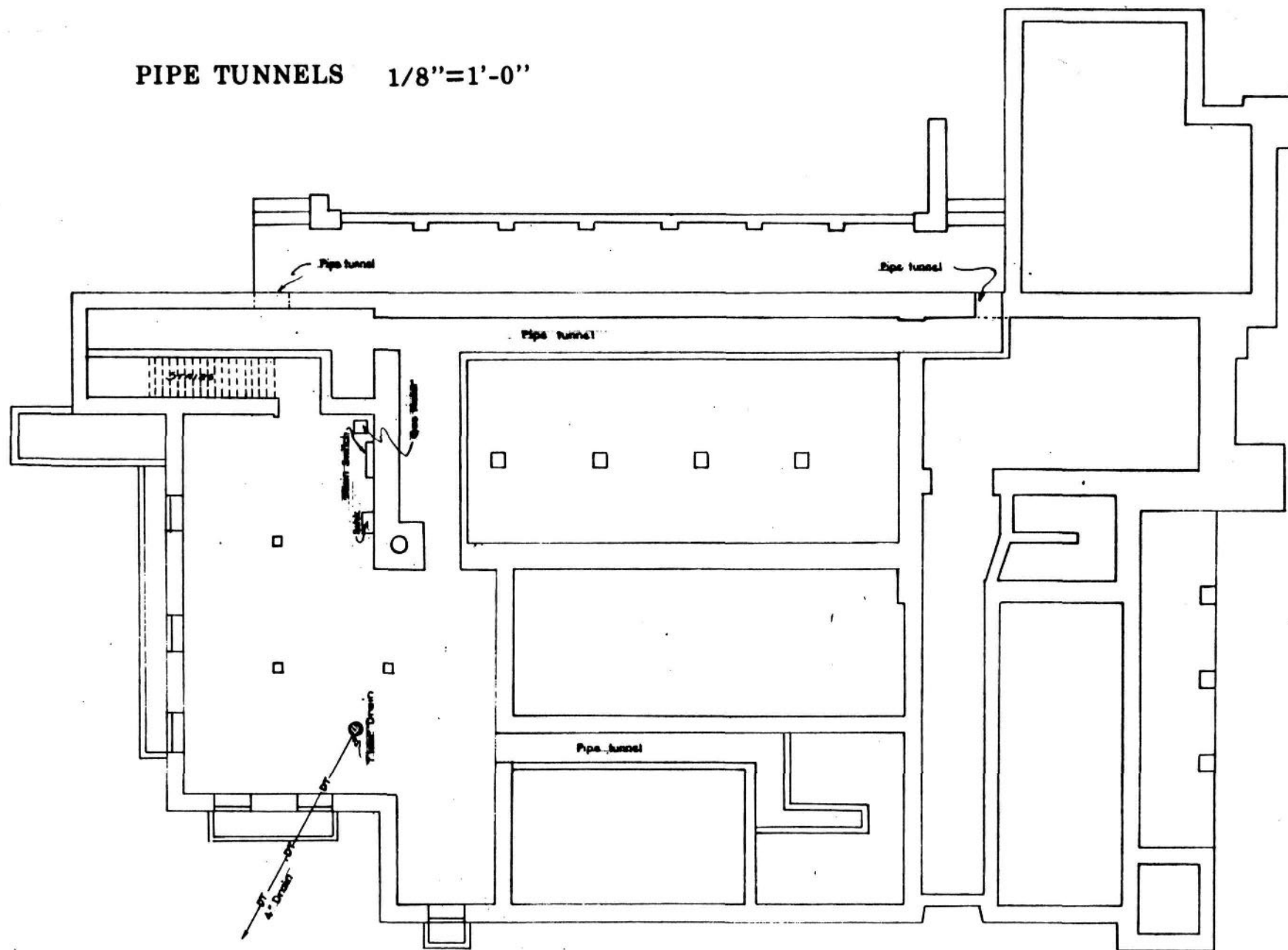

Figure 19.

Steam mains and hotwater lines run from the boiler room under the building through two pipe tunnels.





### Walks, Walls and Parking

At the time of construction, two parking areas had been built. One of the lots located on the east side of the building, primarily for visitor parking, could accommodate up to 18 automobiles. The employee parking area, south of the visitor's lot, holds up to 25 automobiles. On May 11, 1939, \$1,275.00 was allotted from roads and trails funds for the bituminous subsurfacing of the entrance road and east parking lots. A shipment of natural rock asphalt for the project came from Dougherty, Oklahoma. Capital Construction Company of Santa Fe provided the skilled labor and rented a roller, while 25 CCC enrollees spread the asphalt.

After an expansion in the 1950s, the east parking lot is now able to hold 65 automobiles. The west lot, thought also to have been added in the 1950s can hold up to 29 automobiles (Figure 21).

The parking lots are enclosed by adobe walls which were built on a curvilinear grid from the building to the street. According to a July 31, 1940 transmittal form, the walls were built of adobe, covered with 942 square yards of metal lath and plastered with oriental stucco and Atlas cement. The walls range from 4 feet to 6 feet high, and are as wide as 2-1/2 feet. All property walls were completed on June 30, 1939 at a total cost of \$3,141.86.

An entrance sign was built directly into the adobe property wall near Old Santa Fe Trail. River boulders protrude from the wall below the sign while two 7-inch juniper vigas, with a log lintel above, project from the wall above the sign. The sign itself is recessed into the wall and measures 2 feet by 4 feet 3 inches (Figure 22).

Walks on the site are of flagstone laid on a 2-inch bed of compacted sand, and brick on sand. The existing walks were constructed in 1939 at a total cost of \$1,889.17 (Figure 23).

At the front entrance to the grounds, a cattle guard, built of railroad ties and flat iron, was constructed on June 24, 1939 at a total cost of \$745.89. The cattle guard has since been removed, the hole filled and the road repaved.

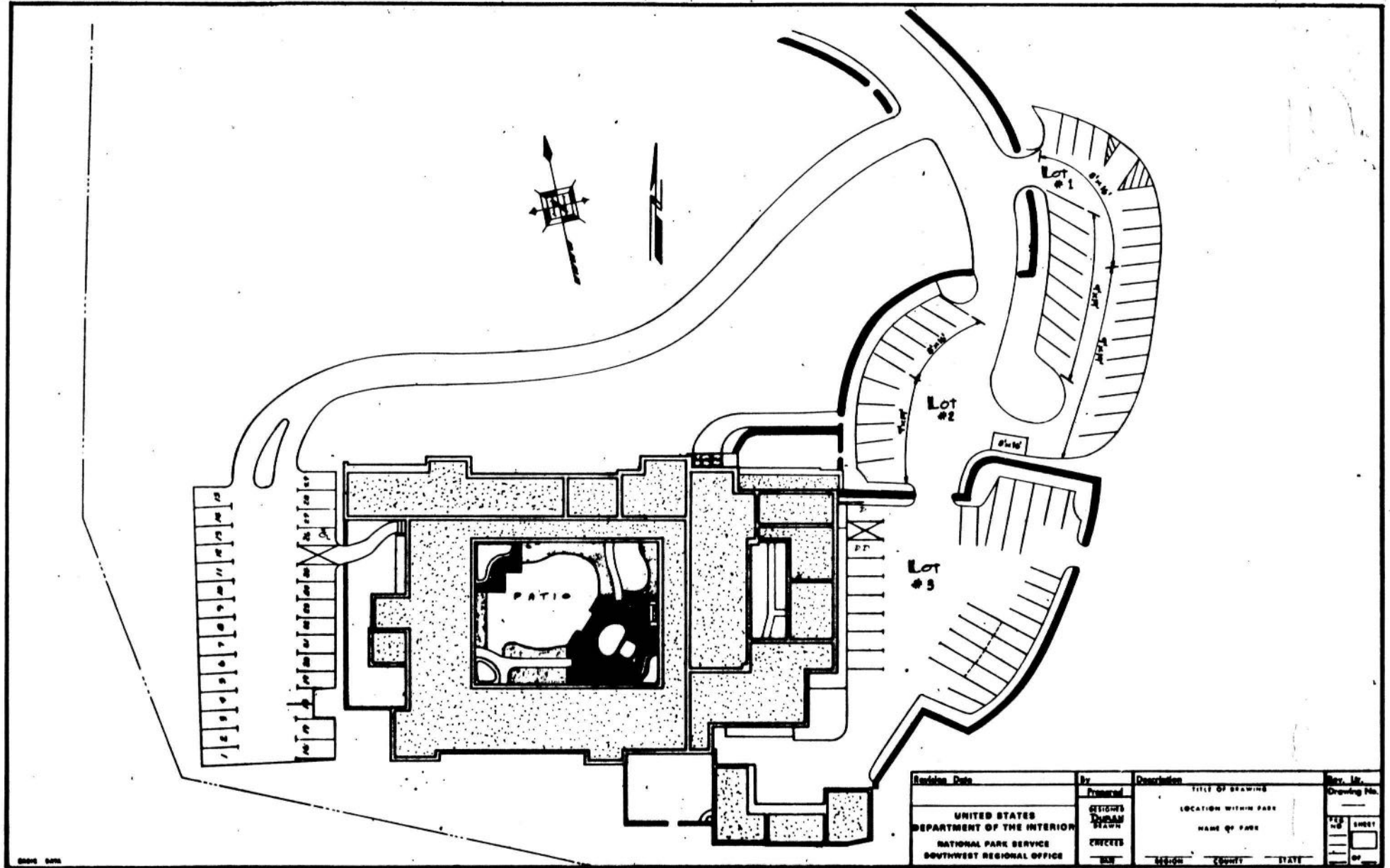

Figure 21.

Ninety-four parking spaces are currently available after an expansion of the east lot and the construction of a west lot in the 1950s.

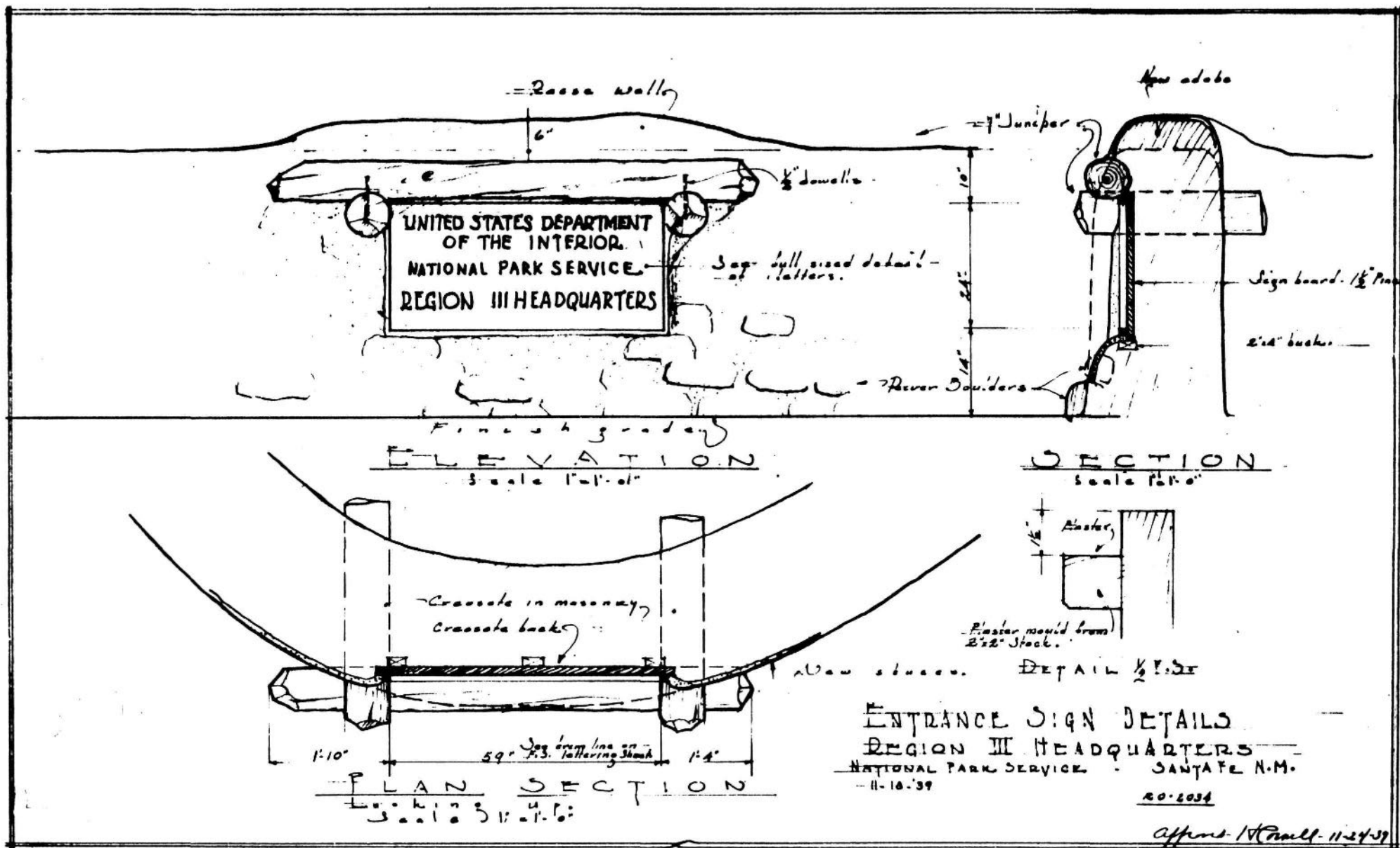

Figure 22.

Entrance sign details show that the sign was built directly into the adobe confining wall.



- 
- 4 Viga: A round wood beam, girder or bridge truss, usually debarked.
- 5 Lintel: A horizontal architectural member supporting the weight above an opening.
- 6 Martinez, Frank. Interview by Steven M. Burke, May 13, 1984.
- 7 Dado: The lower part of a wall of a room if decorated differently from the upper part, as with panels, colors, or an ornamental border. Dado designs are still used today in many adobe buildings in New Mexico.
- 8 Corbel: A bracket of wood, usually decoratively carved, which supports a beam.
- 9 The column bases were later modified. See Chapter 5.
- 10 An adze was frequently used for dressing wood. Seldom seen these days, it is an ax-like tool with an arched blade at right angles to the handle.



## CHAPTER 2: LANDSCAPE

As mentioned in the historical overview, the landscaping for the headquarters building was under the supervision of Regional Landscape Architect Harvey Cornell, and the project was carried out by Associate Landscape Architect John Kell.

The existing landscape, at time of construction, consisted of a variety of plants typical to the area surrounding Santa Fe. Pinons, junipers, and chamisas were the primary plants which Harvey Cornell and John Kell attempted to save and incorporate into a landscape design.

Figures 24 and 25 show what had originally been planned for planting; however, it is difficult to know how closely the landscaping plan was followed.

### Parking Areas

The parking lots appeared to get first attention. First the poor soil from the island in the east parking lot was removed and replaced with good soil. Native brush, consisting of 35 chamisa (also known as rabbit brush), 3 pinon trees, and 3 junipers were planted in the island. The remaining area outside of the walls of the east parking lot was landscaped with 90 chamisa, 8 pinons, and 2 junipers.

### Patios

The conference room patio on the northeast corner of the building became a real landscape work of art. Figure 26 shows the conference room patio landscaping as originally planned by Cornell and Kell. Planted within the patio walls were lilac, shasta daisies, iris, hollyhock, columbine, and an apricot tree with a 4-inch trunk. Surrounding the tree was a 14-foot circular catch basin pitched to collect rain water. The catch basin and walk in the patio were both constructed of flagstone, with grass planted in the cracks. Also built in the patio was an adobe banco with a stone seat. Next to a flagstone sidewalk, just over the conference room patio wall, periwinkle, pinons and more junipers were planted (Figure 27).



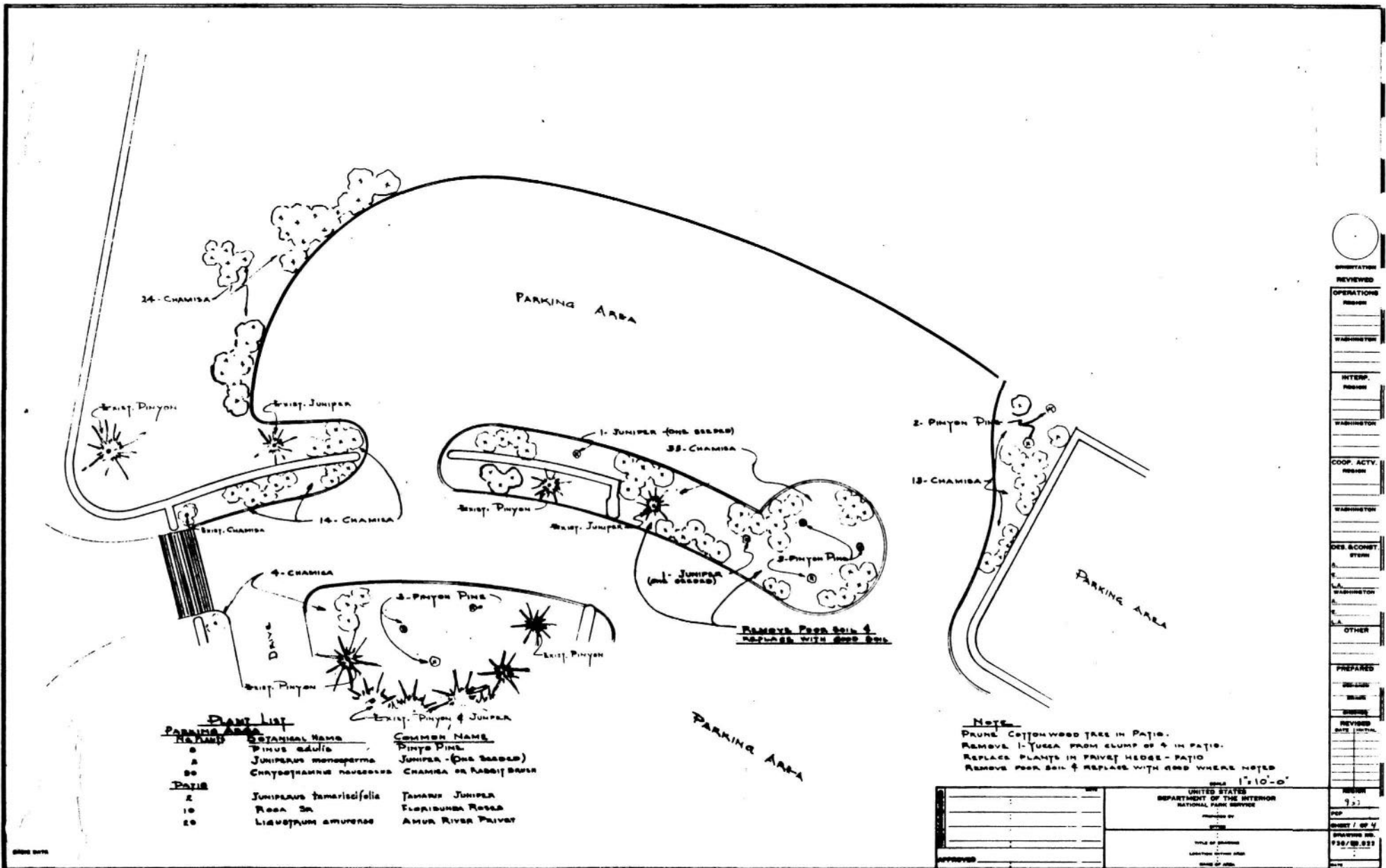

Figure 25.

The original planting plan showing existing and new landscaping at time of construction.

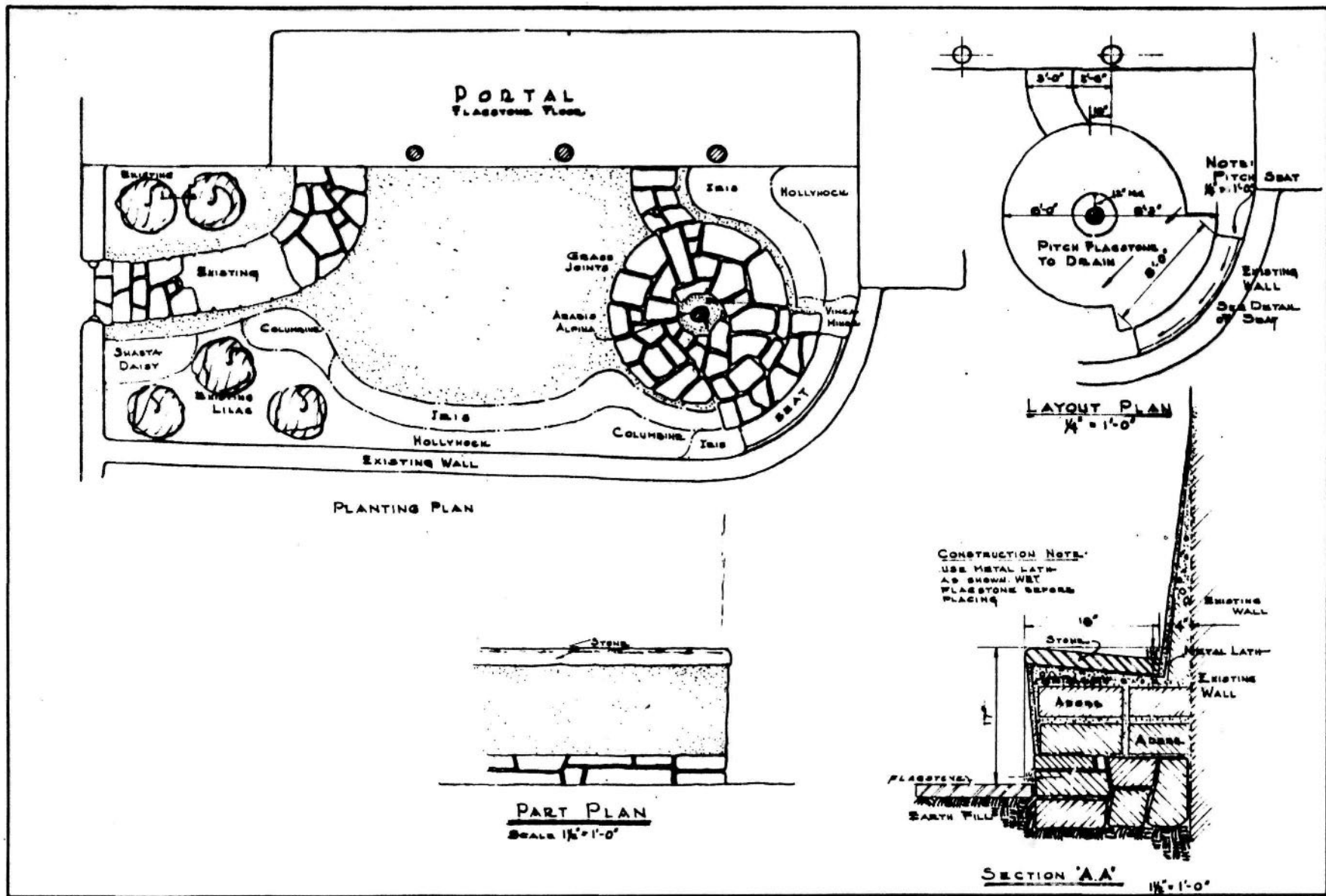

Figure 26.

Conference room patio plan showing the original landscaping, flagstone walks and an adobe banco.



Figure 27.

Fine example of an adobe banco.

The west patio was heavily landscaped with lilac, pinons, forsythia and a plum tree, while the patio to the south of the building had only a few junipers and a small peach tree.

The large interior patio exhibits a wide variety of landscaping elements, including brick walks, adobe bancos, flower beds and grass. According to Carl Walker, "the patio, when first planted, looked as if it was hardly used. Very small plants were planted, but when the trees started growing out it looked much better." Walker said, "there was an apricot tree, cottonwood tree, pear tree, redbud tree and in the northwest corner was a peach tree and apple tree."<sup>12</sup> A fountain and pool, 19 feet in diameter, was constructed in the southeast corner of the patio (Figure 28). The original drawings show that alternate basins were designed. The more ornate of the two has a Spanish concha (shell) motif with a glazed rim (Figure 29). The second basin is simpler in design, of cast concrete, with plain moulding on the rim. This simple basin was actually constructed (Figure 30). A filter was installed soon after the pool was completed to keep the water clean as it passes through the fountain. The filter was placed in a tree well behind the pool. Electric cables and water supply tubes run up the side of the pool then through the fountain and pool wall to the filter. The electric cables were placed underground in waterproof rigid conduit. According to Westley Volney, "the fountain was always a problem. It always leaked and the fountain never really worked right." Volney said "it was repaired in 1972 and seems to be working fine now." Today, lillypads and goldfish are contained within the 944 gallon pool (Figure 31).

The Santa Fe New Mexican thought the transplanting of a large plum tree on the grounds was a noteworthy event. A piece from the paper's special section on July 1, 1939, which covered the opening of the building, describes what had been involved in getting it there:

#### Ten-Year Old Plum Tree Moves to Site

A ten-year old plum tree that weighed 5 tons when transported by truck from Tesuque nearly 2 months ago, appears to be thriving in the small patio at the left main entrance to Region III headquarters of the National Park Service.

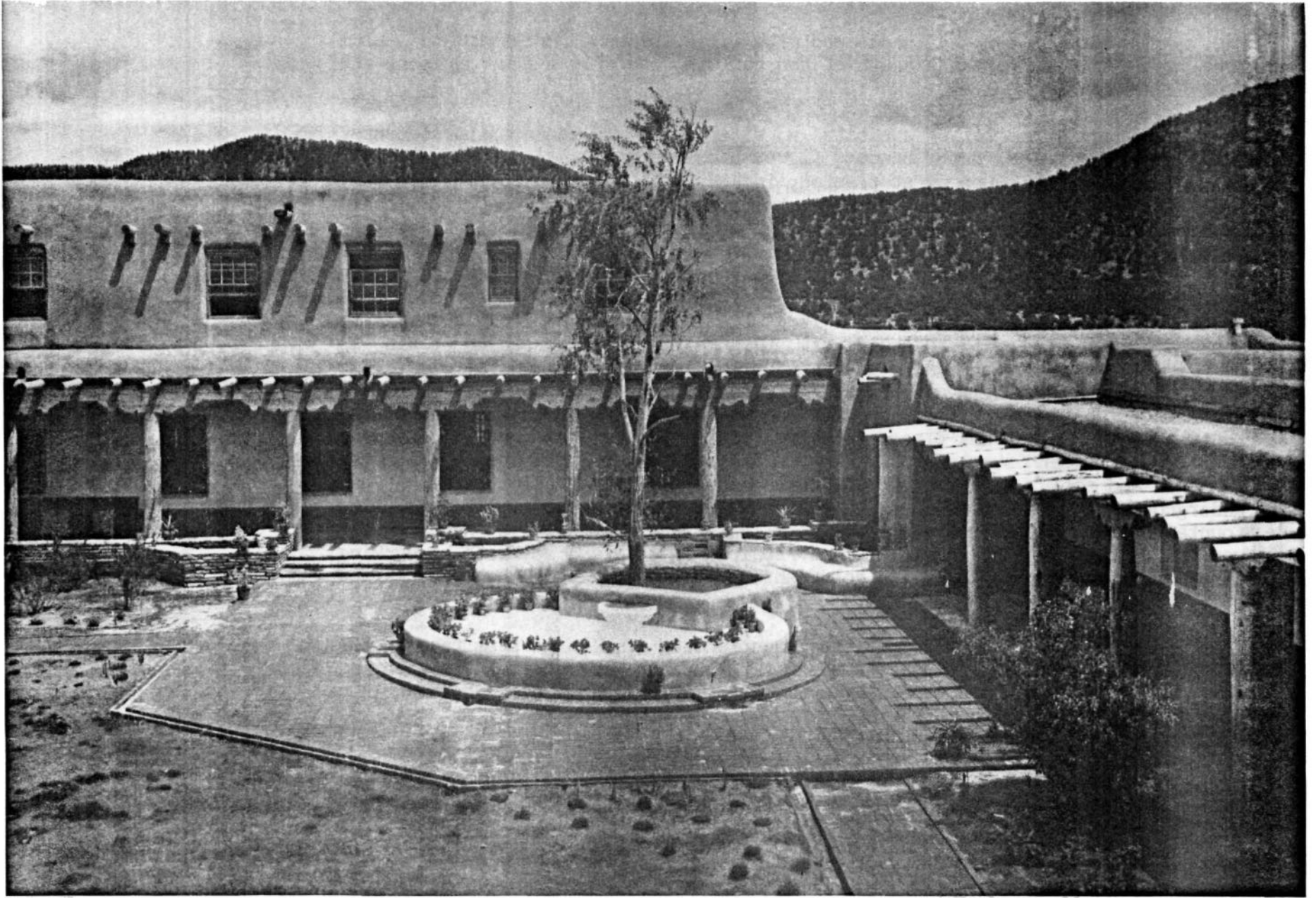

Figure 28.

Great shot of the courtyard, pool and fountain just after completion.

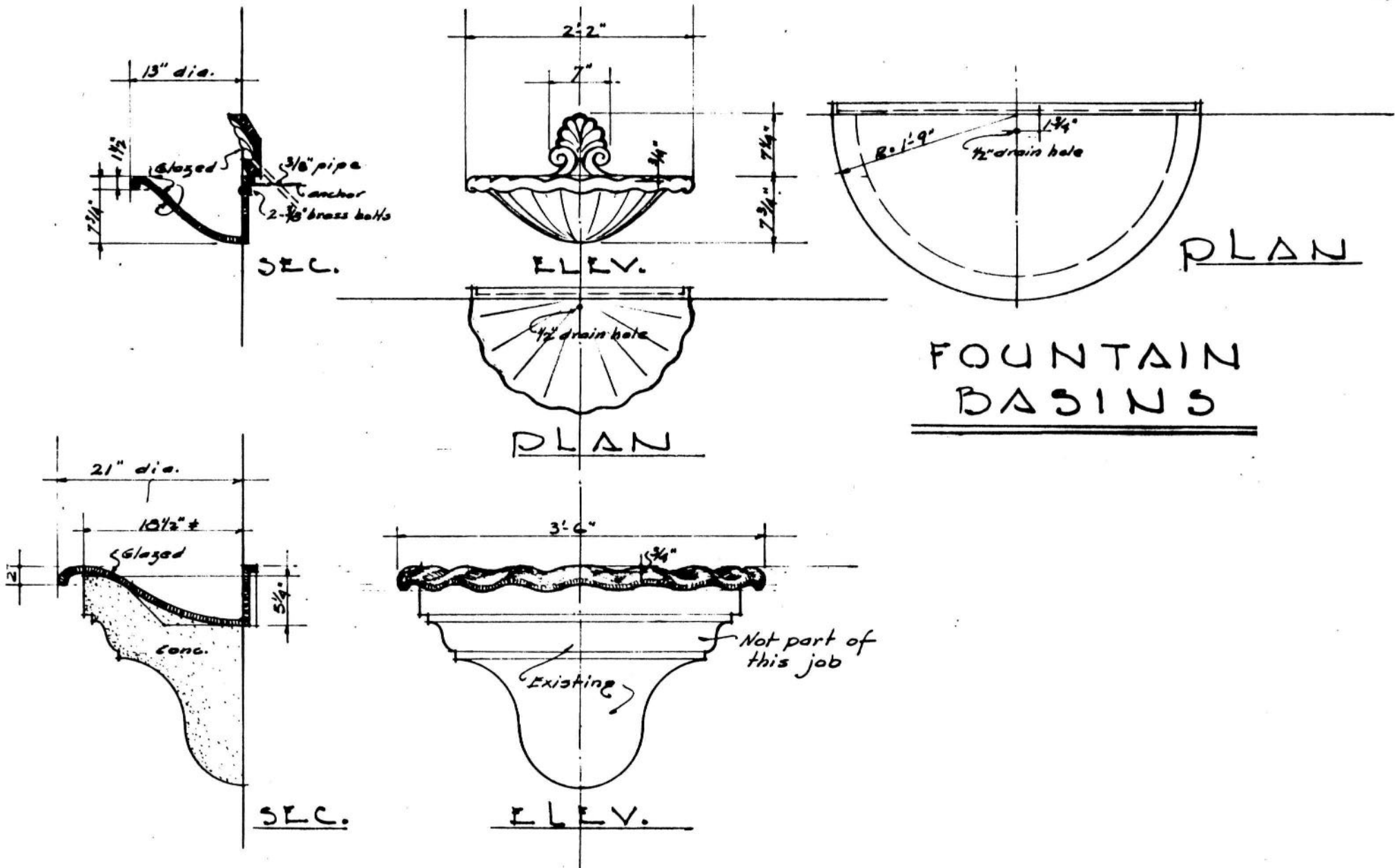

Figure 29.

Fountain basin as originally designed with a decorative glazed rim.



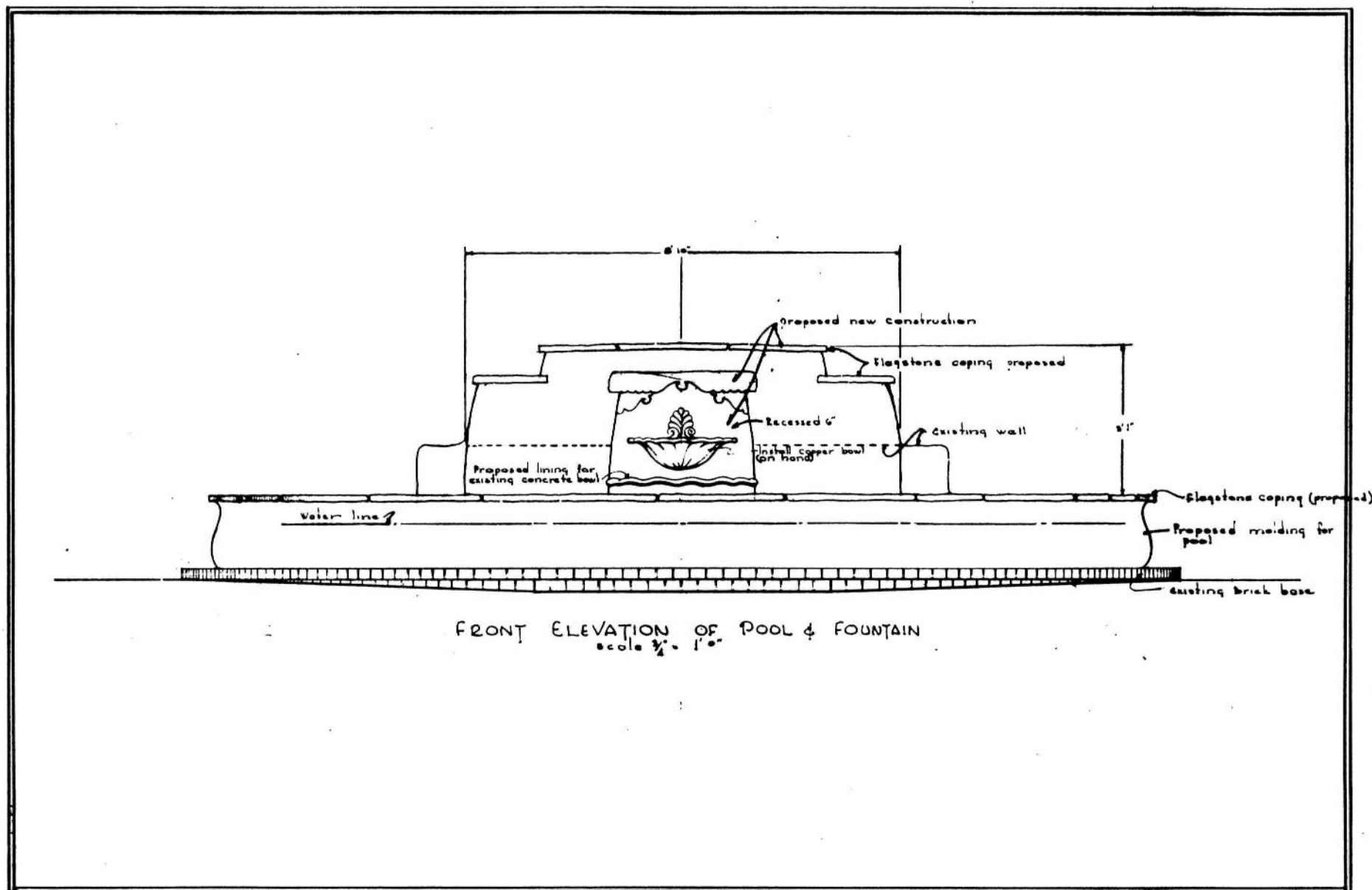

Figure 31.

The 944 gallon pool and fountain was originally designed with a flagstone coping and a glazed rim basin.



Because the tree was over 6 inches in diameter and almost in blossom, special handling was necessary for transplanting. A square was marked around the tree, 3 feet each side of the stem, and a trench dug to a depth of 3 feet. By trenching under the sides and "gophering" through the center, floor timbers 8 feet long were placed under the tree. The sides of the box were attached to the floor and corners reinforced by posts. The box then was nailed, wired, "boomed," and tied with log chains. Skids from a tractor-trailer four-wheel drive truck were placed under the tree. A line from a winch truck was doubled around the pulleys and the tree was coasted upon the platform of the truck by means of pipe rollers between the floor of the box and the skids.

To avoid damaging the well-shaped crown, the tree was moved in an upright position. The top height was about 22 feet above the pavement. This necessitated help from the telephone and power companies for temporary realignment of overhead wires.

Unloading at the Park Service building was the reverse of the loading. After grades had been carefully checked, the tree was pulled into place by running a line from the winch truck past the front entrance and under the patio wall. The tree was pulled into position through an opening that had been made in the wall, and the floor under the tree was removed. Timbers forming the side wall around the square "ball" then were taken out. All settling around the tree stopped after alternate doses of soil and water for 12 hours.

It is ironic that after all these careful preparations the tree apparently did not survive. No plum tree now exists in any of the building's patios.

#### Other Landscaping

A 1938 topography map of the site shows a hill sloping to the east of the building. On the hill is a whole line of existing pinon and juniper, which the plans indicate were to be saved.

To the south of the building, a wide variety of trees and shrubs were planted including Russian olive trees, mountain maples, lilac bushes, chamisa shrubs, plum trees and cottonwoods. Various other plants, such as barberry, yucca, currants, locus, and apple trees also exist on the property.

---

11 Banco: A bench or seat usually built into an adobe wall or planter.

12 Walker, Carl. Interview by Steven M. Burke, January 24, 1985.

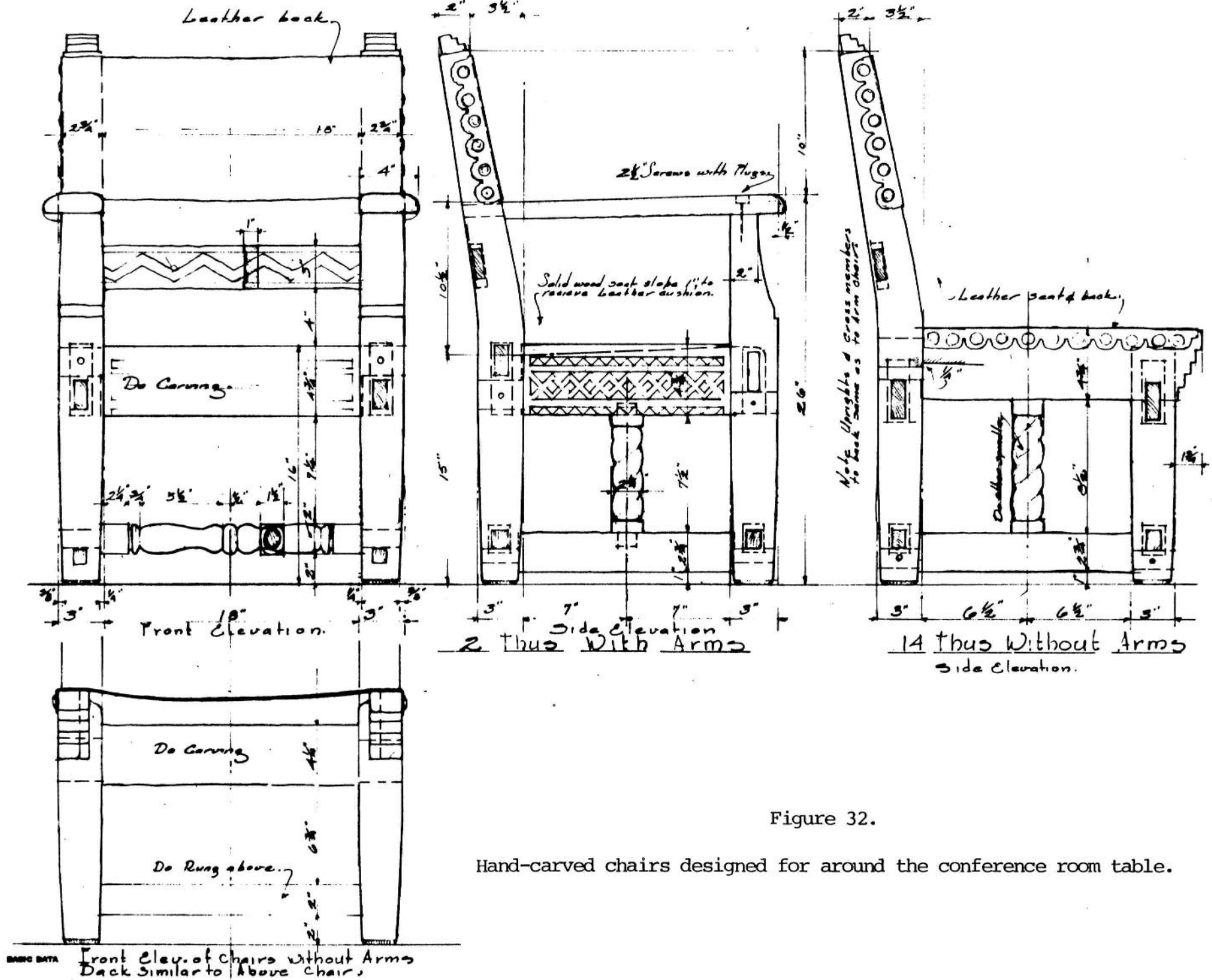

Figure 32.

Hand-carved chairs designed for around the conference room table.

## CHAPTER 3: FURNISHINGS

### The Furniture Designer and Builder

Some fine examples of reproduction Spanish colonial furniture were built in 1939 for the Region III office building. Cecil J. Doty, Associate Architect for the National Park Service, and Architect for the Regional Office building, designed much of the original furniture. Vernon Hunter, local Santa Fean and Director of the Federal Arts Project of New Mexico, supervised the CCC boys who built the furniture. The chairs, desks, tables and patio benches were all hand-built out of select D, local yellow pine.

### Conference Room Furniture

#### Chairs

Cecil Doty designed two different styles of chairs for the conference room table, which remain in use today. Both chairs have intricate hand carving and turned spindles. They measure approximately 24 inches wide, 19 inches long, and 36 inches tall. One type has a leather seat and back, while the other has a wood seat and back made of wood spindles. Each design was produced in both armless and arm chair versions. Mortise and tenon construction was used.<sup>13</sup> The chairs were stained a pale grey, which was rubbed on and then waxed. The other chair style seen in the conference room closely resembles the armless chair, however, this style has more carving, side arms, and a wood seat with a leather cushion. Measuring approximately 24 inches wide, 19 inches long and 36 inches tall, these chairs were also finished with a grey stain, rubbed and then waxed (Figures 32 and 33).

#### Small Table

A small table measuring 30 inches high by 20 inches wide, by 42 inches long was built to match the other conference room furnishings. The table is of a similar design and construction as the chairs, with intricate spindle design carving on the legs, and geometric Spanish designs carved into the rungs and stringers. Dowels, screws, and mortise and tenon joints were used as fasteners. Large lag screws were used to secure the legs, with 45-degree angle

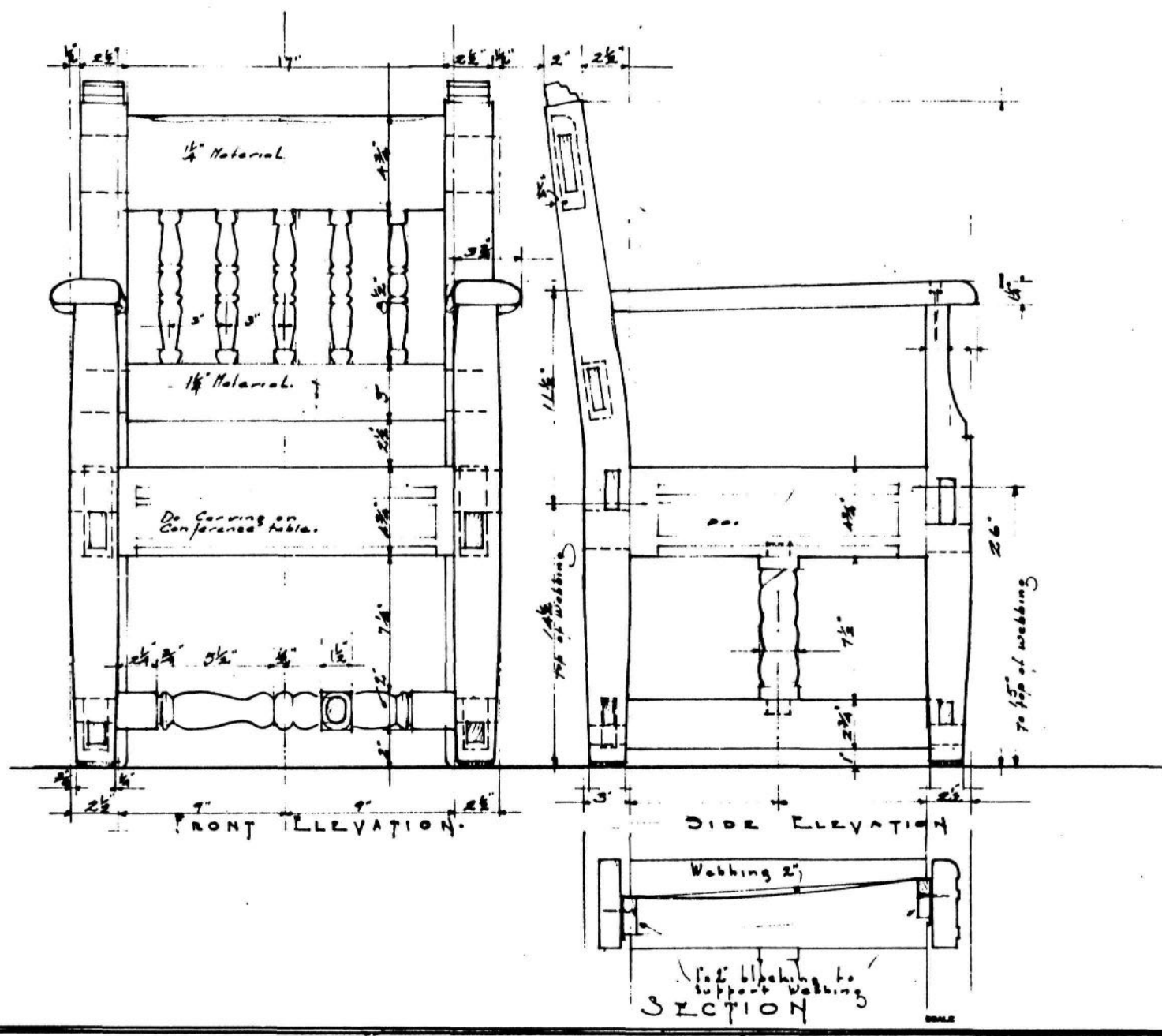

Figure 33.

Conference room chairs designed with arms for around the table.

bracing, to the table top. Like the chairs, this table was finished with a greyish, rubbed stain (Figure 34).

#### Large Table

One of the most spectacular pieces of furniture in the building is the large conference room table. The table is supported by six massive square legs carved in a spindle design. The mortise and tenon joints and large screws used in the construction were cleverly hidden by carvings. The legs and stringers on the ends of the table resemble Spanish posts and corbels seen on southwestern buildings. The table was built of natural pine wood, adzed smooth, and then finished with a clear stain and paint pigment which was wiped off and waxed (Figure 35). In an interview on January 24, 1985, retired Landscape Architect Westley Volney said that in 1955 John Moseley, also a Landscape Architect, had the smaller<sup>14</sup> conference room table and some chairs built to match the original design.

#### Foyer

#### Large Desk

Another unique piece of furniture in the building is a large desk now located in the foyer. The desk was built at the same time as the conference room furniture and exhibits the same construction techniques. The front of the desk has drawers and cupboards while the back and sides have solid panels. The piece was constructed of local white pine, adzed smooth, and then finished with a clear stain paint pigment which was wiped off and waxed (Figure 35).

#### Coffee Table and Chairs

In 1964 new furniture was built for the building's lobby. A small round coffee table with matching chairs was designed by "various" people in the Region (see title block on drawing). The table measures approximately 16-1/2 inches tall and 40 inches in diameter. It was constructed of grade "B" pine. The table has a lower shelf 1-1/4 inches up from the floor, with 16 legs equally spaced between the bottom shelf and the table top. Unlike the carved legs on the conference room table, the coffee table legs were saw cut, not turned or hand-carved. The table top has a 1/4-inch piece of glass inset 3 inches from

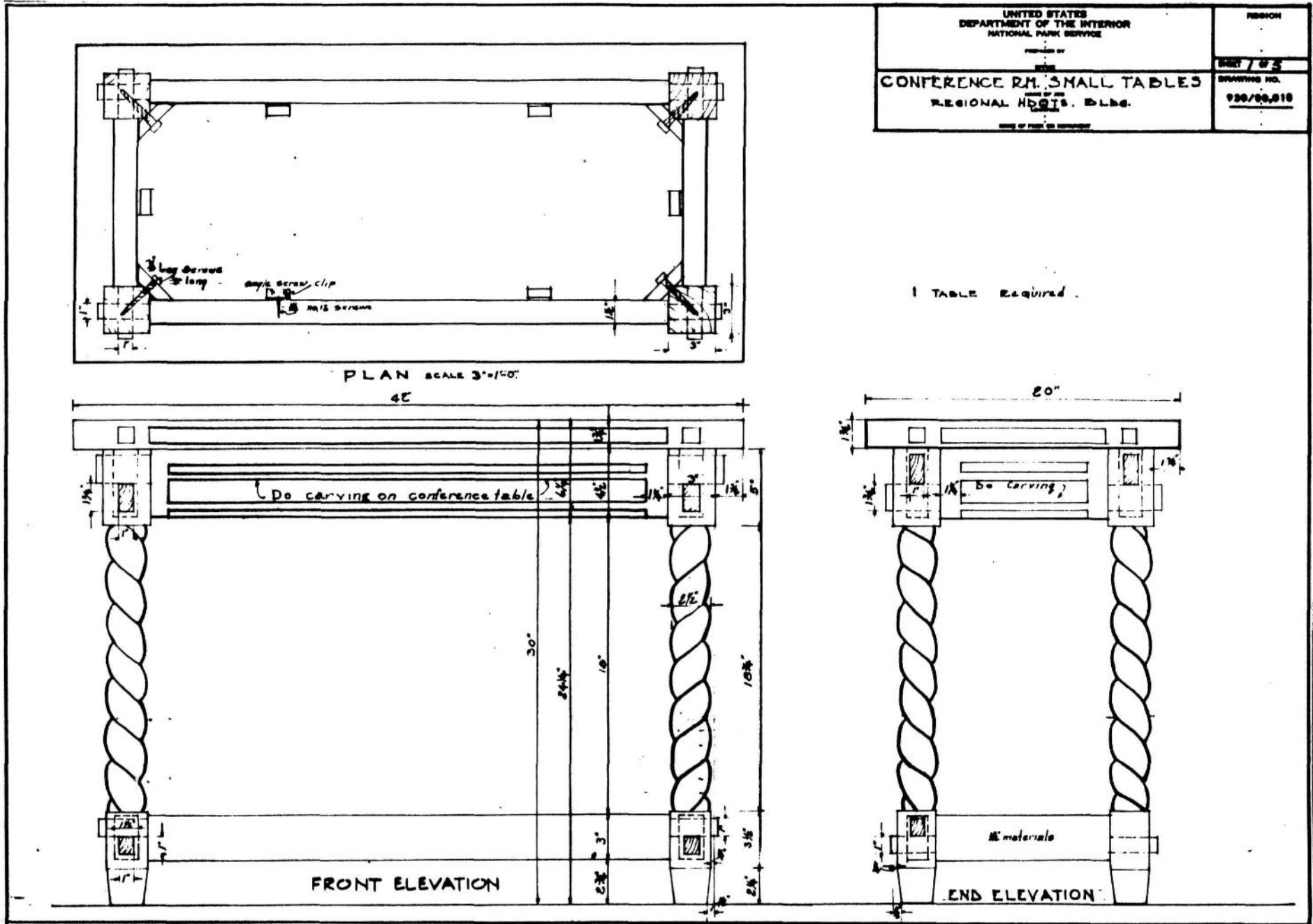
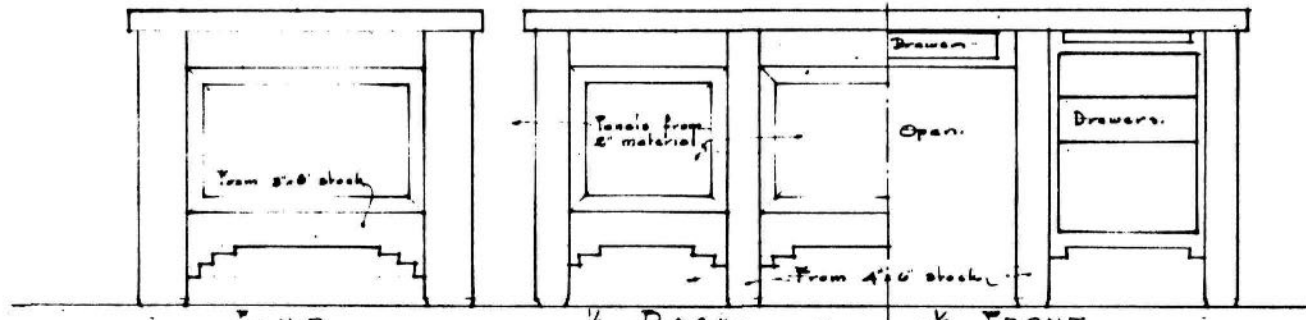
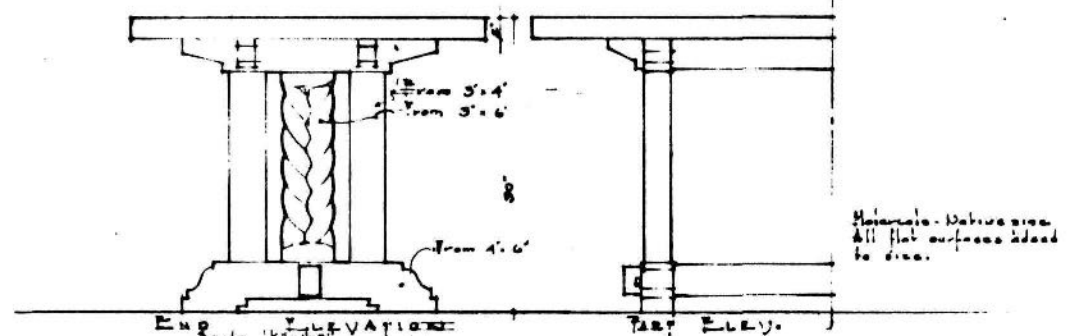

Figure 34.

Small hand-carved table designed to match other conference room furnishings.



END                      1/2 BACK                      1/2 FRONT  
 Material: Native pine - Mortise & Tenon, doweled - All surfaces look added to size & finish.  
**DETAILS OF LARGE DESK**



END ELEVATION                      SIDE ELEV.  
 Scale 1/2" = 1'-0"  
**DETAILS OF TABLE - NOT MEASURED**

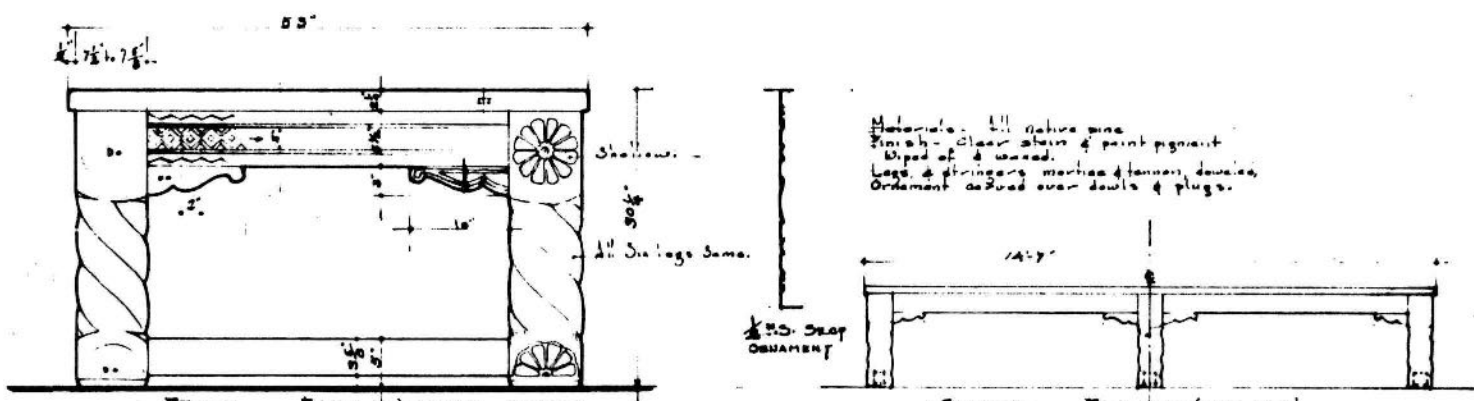

END ELEVATION                      SIDE ELEVATION  
 Scale 1/2" = 1'-0"                      Scale 1/2" = 1'-0"  
**DETAIL - TABLE CONFERENCE ROOM REGION III HEADQUARTERS**

Figure 35.

The large conference room table has six massive hand-carved legs. Mortise and tenon joints, dowels and lag screws are used throughout.



the side and 1/4 inch into the top. Mortise and tenon joints from the 16 legs are exposed on top (Figure 36).

Chairs were constructed at the same time to match the table. The chairs stand 36 inches tall with small (10-inch) backrests. They are 20 inches wide and 15 inches long. Unlike the hand-carved design on the conference room chairs, the coffee table chairs were saw carved and routed. The chairs have 1/2-inch plywood seats with cushions and were finished with a stain which the drawing identifies as "Old English Oak Stain-Blond-It Driftwood" to give the wood a clear rubbed effect. Both the table and the chairs were treated with a flat clear varnish (Figure 37).

According to the specifications found in the Federal Archives Center in Denver, the Civilian Conservation Corps was requested to construct four tables, six stools and a number of oak binding sticks for use in the drafting room. Unfortunately, only one stool remains in the building while the whereabouts of the other original drafting room furnishings are unknown.

Camp SP-1-N has been requested by the Branch of Plans and Designs, Region III, to construct the following drafting room and office equipment in the SP-1-N carpenter shop:

- 4 Drafting Tables, top dimensions: 6'0"x 3'4"
- 6 Drafting Stools
- 1 Partitioned Cabinet

Material for the construction of this furniture will be furnished by the Branch of Plans & Designs, and all units will be constructed according to plans on file in the Regional Office.

In addition, the following oak sticks, 1-1/8"x 3/16" thick, for binding 1938 National Park and Monument Master Plans are proposed:

6	pairs	13 $\frac{1}{2}$ "	long
33	"	19"	"
7	"	19 $\frac{1}{2}$ "	"

6	"	22 $\frac{1}{4}$ "	"
44	"	23"	"
26	"	25"	"
6	"	25 $\frac{1}{4}$ "	"
7	"	26"	"
5	"	28 $\frac{3}{4}$ "	"
	<u>13</u>	<u>31"</u>	"
(Total:	153 pairs	)	

These sticks are to be cut to size and length, matched as to length, and number and location of holes, and are to be delivered in a finished condition, ready for use. Fortunately, close contact can be maintained between the B.O.P. & D. and the SP-1-N carpenter shop, and since these binding sticks must be made to fit individual master plans of various sizes, a much more satisfactory job can be done through a work project than could be obtained for a like expenditure in the open market.

Materials for all the above equipment will be furnished by the Branch of Plans and Designs, and only man days will be necessary for this job.

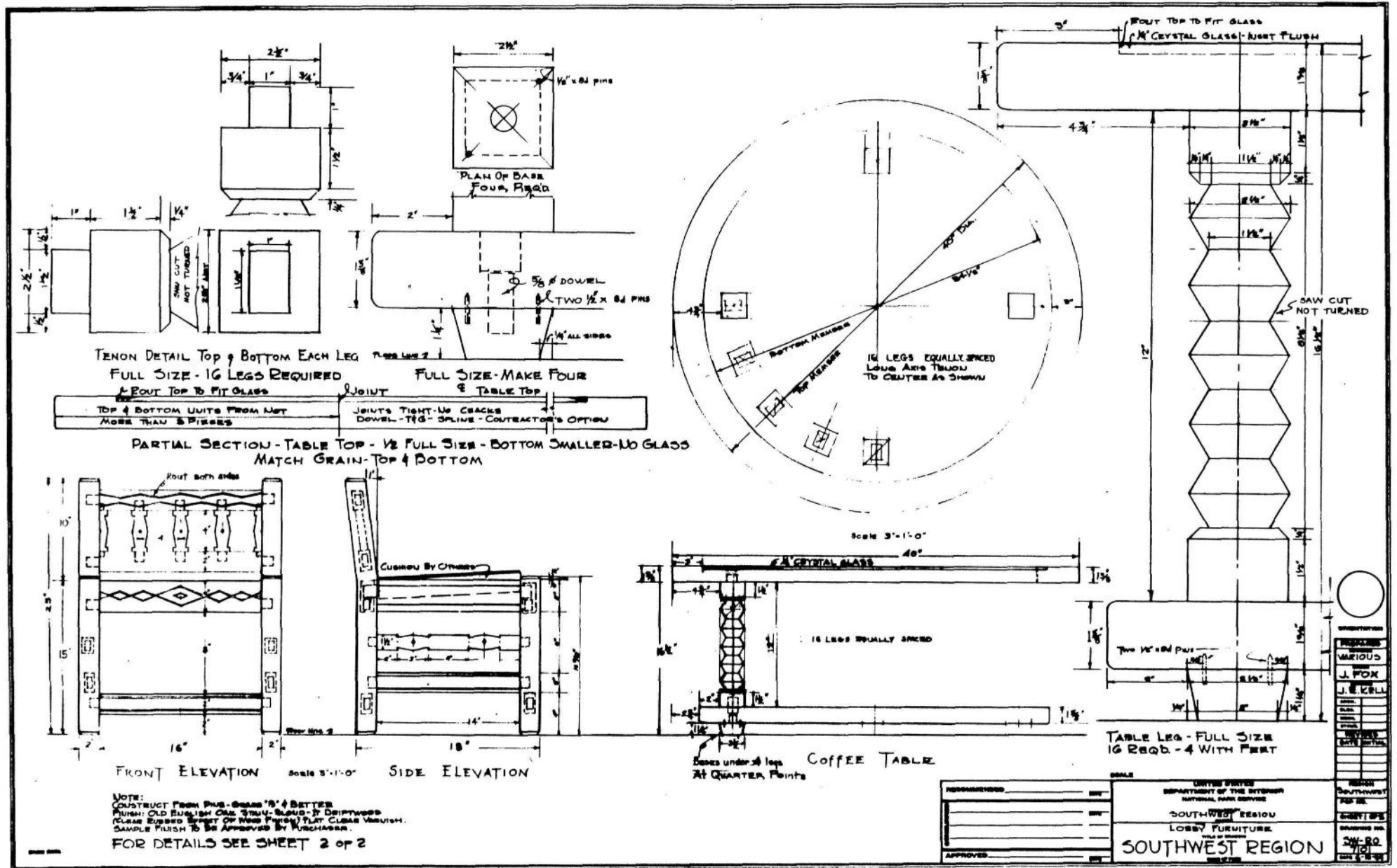

Figure 36.

Coffee table for foyer designed to reflect the hand-carved Spanish style seen in the original furniture.



## Other Original Furnishings

### Patio Benches

Doty also designed four benches to be placed under the portal in the large patio. Three of the benches remain on the patio, while the other has been moved to the upstairs corridor. Two of the benches are 5 feet long and two are 6 feet. Carved rungs and stringers give the benches a Spanish colonial appearance common to the other furnishings in the building. Sharp geometric designs, dowels, mortise and tenon joints and lag screws were all used. The benches were constructed of native yellow pine and were finished with a rubbed grey stain (Figure 38).

### Fine Arts

In 1940 the Region gave John Kell, Associate Landscape Architect, money to purchase artwork for the building. According to both Carl Walker and Westley Volney, Kell was not allowed to spend more than \$100 at each pueblo. He was sent out to buy Navajo rugs and pottery. Carl Walker stated, "At that time each piece was only \$5-10." The Region now owns 12 Santa Clara pots of which seven are signed Lela Gutierrez. Many of the pots are vessels of a closed form. Three pieces of pottery from San Ildefonso signed Maria and Julian Martinez and three pieces from Cochiti Pueblo signed Agapina Quintana are also owned. Currently the Region has 12 rugs on loan from the Amelia White Collection in the Navajo Ceremonial Museum and owns approximately 46 Navajo rugs. Also owned are a number of drawings, paintings and prints.

Oden Hullenkramer, a local Santa Fe artist, was commissioned in July 1939 through Emergency Relief Funds to paint an oil painting of Stephen T. Mather, first Director of the National Park Service. The large painting depicts Mather on horseback riding along a ridge in Glacier National Park, Montana. It was originally placed in the Mather Room (conference room), but was later moved to the foyer where it remains today. ("Painting for Park Service," Santa Fe New Mexican, July 1939), (Figure 39).

Other pieces of art owned by the Region include: 5 oil paintings, 13 water colors, one of which is an original done by Milton Swatck in 1938 portraying the Regional Office Building, 1 acrylic, 5 drawings, 9 pen and ink drawings



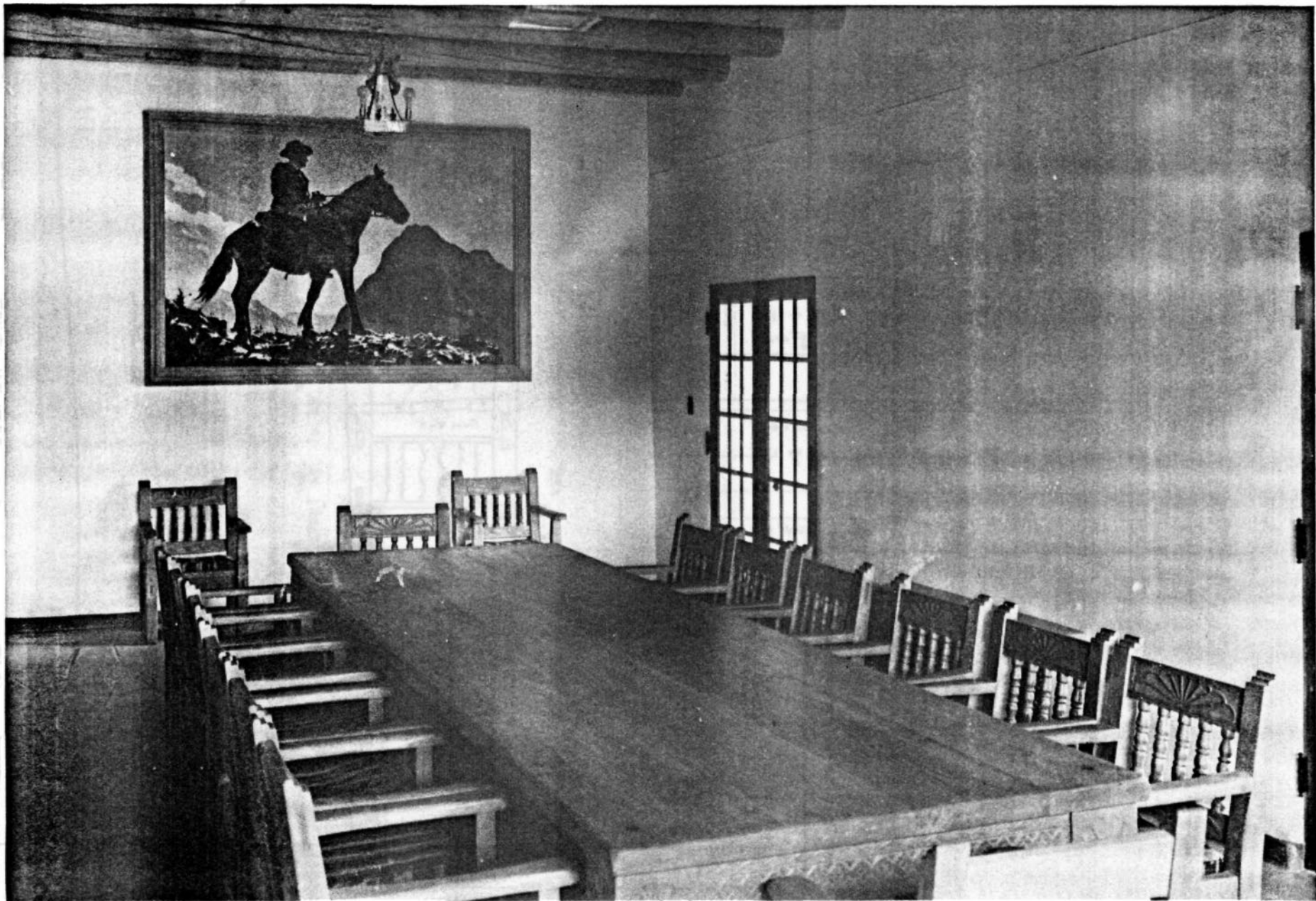

Figure 39.

Oil painting of Stephen T. Mather as originally hung in the conference room.

including an original by Cecil Doty of the building, and approximately 20 prints.

#### Fixtures

Similar to the building's furniture, the light fixtures and switch covers have Spanish colonial motifs. They were made by the CCC in Santa Fe, with Vernon Hunter directing the work. All the fixtures were constructed from pressed tin and have been rewired to meet current building and safety codes. According to Frank Martinez, GSA maintenance worker, the original fixtures remain intact; however, various incandescent fixtures have been installed for additional light.

#### Balustrades

The original balustrade on the main stairway was designed to reflect the same Spanish style as seen in the furniture. The balusters and rails were to be hand-carved out of local white pine. Plans were drawn for an elaborately carved 2-foot 10-inch gate to be placed just above the top step. Apparently neither the balustrade nor the gate were ever built as nothing resembling them is evident today (Figure 40). The present balustrade consists of solid adobe walls with round wood handrails. A balustrade located in the Public Affairs office on the first floor has five hand-carved balusters (all different) and is supported vertically by the adobe wall and two 6-inch by 6-inch wood posts. This balustrade also matches the Spanish style of the conference room furniture (Figure 41).<sup>15</sup>

---

<sup>13</sup> Mortise and tenon: An opening in a wood member to receive a projection on the end of another wood member, forming a joint.

<sup>14</sup> Volney, Westley. Interview by Steven M. Burke, January 24, 1985.

<sup>15</sup> Balustrade: A railing consisting of a handrail on balusters (spindles), sometimes on a base member and sometimes interrupted by piers (supporting posts).





## CHAPTER 4: BUILDING ALTERATIONS AND ADDITIONS IN THE 1940s AND 1950s

1941

### Stair Alterations

The building had only been opened a year when employees began to complain about tripping on the log stairs. After careful measuring, it was discovered that the logs were uneven. To rectify the situation, new treads and risers were constructed over the original log stairs. The new treads and risers were constructed of oak and were screwed down to leveling blocks which had previously been attached to the logs. When remodeling neared completion, the plaster walls were patched and the screws concealed under false pegs. The stair exists today as it was remodeled in 1941. All of the new treads measure 12 inches except the first which measures 13 inches, and all of the risers measure 6-7/16 inches except the first which measures 7 inches (Figure 42).

Also shown on stair remodeling drawings were oak dust trim pieces, to be placed on each step, and a new handrail. The rail, to be hand-made in Santa Fe, is shown in Figure 43. The design of the railing called for the ends to be bent in a curve and the rail itself to be a square, smooth bar with decorative metal brackets. As the original (1939) railing is still in place, it is unlikely that this more ornamental rail was ever constructed.

### Proposed Library Addition

In February 1941 drawings were done on a new library to be on the southwest corner of the building. The library was to add approximately 588 square feet to the existing structure and was to be constructed of pumice block and then stuccoed. This addition was never built.

### Service Building Addition

Also in February, an addition to the service building was underway. Two service washrooms, a storage room and a double garage were scheduled for construction directly east of the existing building. The south and east sides of the new garage were constructed on top of the existing property wall and a 4 or 5-inch concrete slab was poured for the floor. Two wooden sliding garage



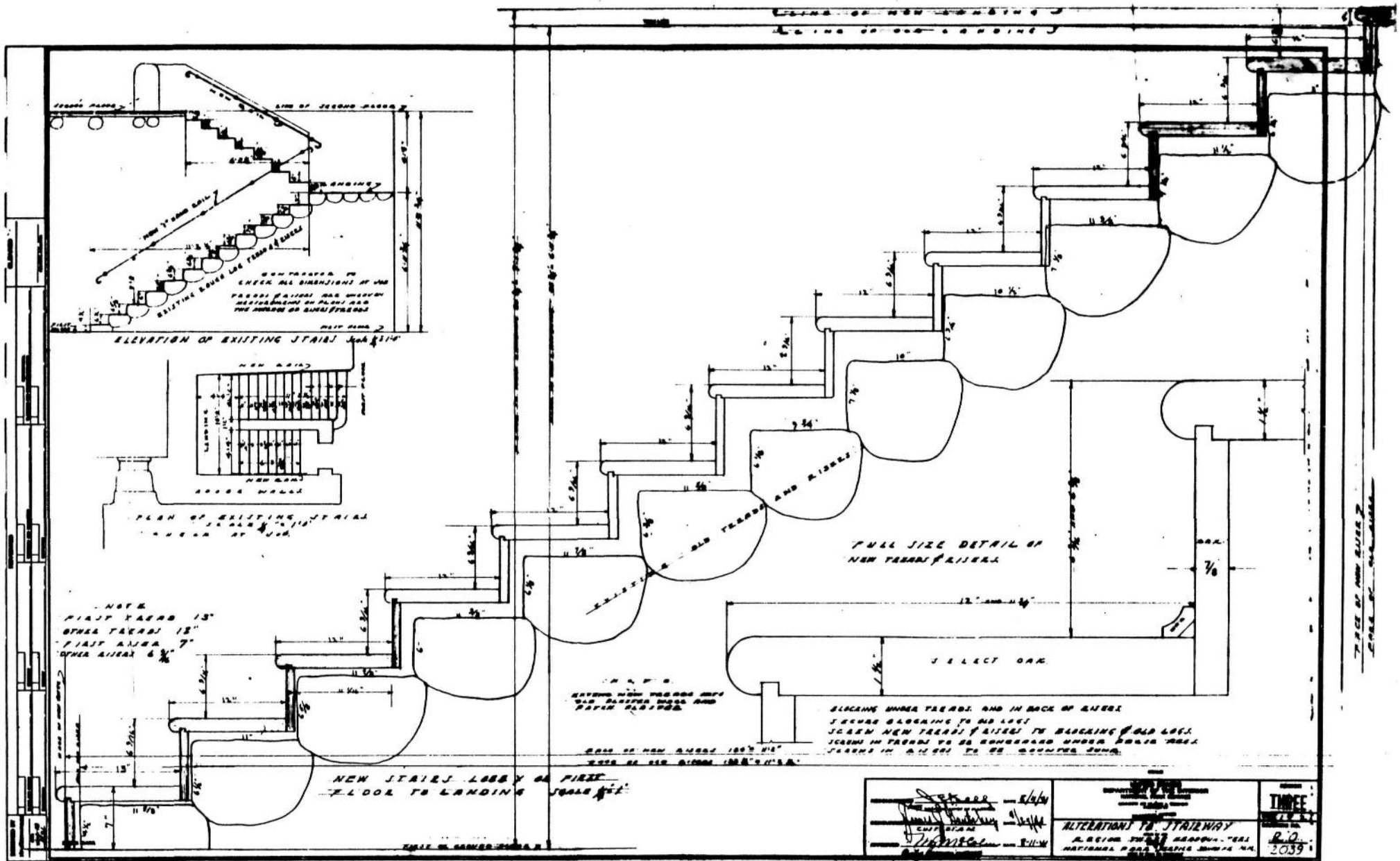

Figure 42.

Original log stair to the second level modified in 1941 with new oak treads and risers.

doors were built of tongue and groove V-joint stock. The north wall of the file rooms was constructed of 8-foot exposed vertical logs, 7 inches in diameter, with a 7-inch viga acting as a lintel above. The addition was finished after the final application of cement chinking between the logs and three coats of cement plaster over the exterior and interior adobe walls (Figures 44 and 45).

Listed below are the equipment requirement lists, specifications and bill of materials for the Service Building addition which were located in the Federal Archives in Denver.

#### EQUIPMENT REQUIREMENTS

List equipment items essential for completion of job. State whether available.

Concrete Mixer) --- All Available  
Hand tools )

#### ESTIMATE OF COST

1. Bill of Materials: Unit and total prices, differentiate between emergency funds and contributions by park authority or sponsor.
  2. Skilled Labor: Number of hours contemplated, hourly rate and total cost for each type of labor, except CCC.
  3. Equipment: Rental only -- type, hourly rental, total cost, include operator when necessary.
1. Bill of Materials: Attached
  2. Skilled Labor: None
  3. Equipment Rental: None

SPECIFICATIONS

The service building addition will consist of a new two car garage 24' x 22' and two service rooms, approximately 14' x 27' combined. Both rooms and garage will be constructed of adobe brick and plastered with cement and adobe plaster. The floors will be constructed of 4 or 5" concrete. The roofs will be constructed of vegas and lumber and covered with tar-paper. (See plan R.O 2035)

Job 193, Class 120, "Service Building Addition"BILL OF MATERIALS

4	pcs. 2"x6"x14', S4S, B&Btr. Whitepine	\$140.00/BM	\$7.84
2	pcs. 2"x4"x14', #2 comm. White pine		.74
2	pcs. 1"x4"x14', S4S, B & Btr. White Pine		1.76
2	pcs. 2"x4"x14', S4S, B & Btr. White Pine		2.52
2	pcs. 1"x4"x14', " " " " " "		1.10

Doors:

1	pc. Double sliding bar track for 8' x 9" openings & Hanger-brackets.		\$25.00
160	pcs. 1"x6"x8', V-joint, #2 comm. fir.		\$36.48
2	pcs. 2"x4"x8', S4S, B & Btr. White Pine		1.54
275	ea. Bolts, 1/2"x2 1/2", machine, black		4.68
1200	ea. Washers, 1/2", iron, black		1.17
325	ea. Bolts, machine 3/4"x3", black		6.01
8	ea. Butt Hinges, 5"	at \$1.34/pr.	10.72
26	pc. 2"x6"x8', S4S, B & Btr. White Pine		14.56
5	Door locks, ordinary	at .80/ea	4.00

Plumbing-Heating:

2	wash basins, porcelain, 19" x 17"		11.90
2	pr. Faucets, (hot & cold)		3.70
40	ft. iron pipe, 2", black		7.75
60	ft. iron pipe, 3/4", black		3.77
4	ea. ells, 3/4"		.29
1	ea. ell, 2"		.38
1	ea. Tee, 2"		.49
1	ea. Wipple, 3/4", black		.05
1	ea. Tee, 3/4", black		.09

Electrical:

60	ft. conduit, 3/4" rigid	10.80
10	Outlet boxes, 4"	1.90
2	Convenience outlets, single, w/brass plate	.86
		<u>No Cost</u>
26	cu. yds. Gravel	" "
27	cu. yds. Sand	" "
5000	Adobe Brick	" "
15	Logs, 8"x8'	" "
1	Logs, 8"x16'	" "
300	Logs, 3" random lengths	" "
1	Logs, 15" x 7'	" "
12	Logs, 9"x17'	" "
5	Logs, 9"x5'	" "
10	Logs, 8"x21'	" "
6	Logs, 12"x3'6"	" "

---

 \$ 937.96

 Plus 10% contingency: ~~85.27~~

Grand Total: \$1023.17

Job 193, Class 120, "Service Building Addition"
BILL OF MATERIALS

4	pcs. Timber, 6"x8"x8'	#1, Common Oregon Fir S4S	\$ 7.32
1	" " , 8"x8"x8'	" " " "	\$66.00/BM 2.84
1	" " , 6"x8"x8'	" " " "	65.00/BM 2.18-
1	" " , 4"x8"x12'	" " " "	65.00/BM 2.08
1	" " , 4"x8"x16'	" " " "	65.00/BM 4.16
1	" " , 8"x10"x6'	" " " "	66.00/BM 2.64
2	" " , 8"x10"x12'	" " " "	10.56
2	" " , 6"x12"x8'	" " " "	3.00 est.
2	" " , 6"x12"x24'	" " " "	10.00 est.
2	" " , 6"x10"x12'	" " " "	7.80
2	" " , 4"x6"x24'	" " " "	10.00 est.
1	" " , 3"x6"x28'	" " " "	10.00 est.
11	pcs. Lumber, 2"x4"x8'	" " " "	\$55.00/BM 3.25
2	" " , 2"x4"x14'	" " " "	55.00/BM 1.05
6	" " , 2"x4"x12'	" " " "	55.00/BM 2.64

24 ea.	Dowels , 3/4"x6"		.33
1 gal.	Plastic Cement, 10#		.90
920 sq. ft.	Sheathing, 1" #3	at \$ 43.00/BM	39.56
2400 sq. ft.	Roofing felt, 15# (6 rolls)	" 2.65/ea	15.90
800 sq. ft.	Flaxine Roofing Felt, 55#(8 rolls)	at 2.55	20.40
3 drums	roofing asphalt, 400#	at 45.00 ton	27.00
200	brick, red common	at 1.60/C	3.20
250 sks.	Cement, Portland, (in paper bags)	at .70/sk.	175.00
16 ea.	Terra cotta Hue Tile		2.40 est.
4 gal.	Paint, White "Konnac"	at 3.50/gal.	14.00
50 sks.	Cement Plaster, Fibered&Non-Fibered	at 1.11	55.50
1700 sq. yds.	wire mesh, 2"x48", (26rolls)	at 6.83/roll	177.58
125 sq. yds.	Metal Lath, Galv. 2.2#	at .23/yd.	28.75
175 lin. ft.	Sheet iron, 14", Galv.(flashing) 26 ga.		16.54
250 lin. ft.	Steel, reinforcing, 3/8" round		43.71
1200 sq. ft.	Wire Mesh, No. 6 x 4', No. 10		27.00

Nails

100 lbs.	#8 common		5.25
25 lbs.	#3 fine galv.	at .10/lb.	2.50
20 lbs.	#10 common	" .08/lb.	1.60
25 lbs.	#16 common	" .08/lb.	2.00
25 lbs.	#20 common	" .08/lb.	2.00
20 lbs.	#6 common	" .08/lb.	1.60

Windows:

4 D.H.	Sash, 2'-10"x4'-6" w/2" Wood Sash		
	balances and window frame & balance		34.00
2 pcs.	2"x8"x14', #2 common pine	at 41.00/M	1.56



## JUSTIFICATION

This job application requests the approval of 2150 CCC man-days and \$1023.17 funds for use on Job 193, Class 120, "Service Building Addition", Region III Headquarters.

The man-days and funds will be expended in constructing an additional building on the now existing service building at the rear of the Region III Headquarters Bldg. The new addition will consist of two car garage-rooms and two small rooms to be used as service wash-rooms and storage space. The building will be built onto the plastered walls and the building now existing. It will be constructed of adobe brick on rock foundations and plastered with cement and adobe plaster with a 4 or 5" concrete floor. (See plan R.O. 2035). The sand, gravel, adobe brick and logs can be furnished free of charge with the exception of the expenditure of CCC man-days.

The man-days and funds are available on the Current Work Program Outline as follows:

Class 120, Power Shed	-----	300 m-days	\$300.00
Class 137, Incinerator	-----	100 m-days	50.00
Class 141, Drinking fountains	--	250 m-days	50.00
Class 148, Barbecue Pits	-----	100 m-days	50.00
Class 157, Furniture	-----	400 m-days	400.00
Class 157, Plastering Walls	----		173.17
Class 202, Truck trails	-----	1000 m-days	
Total:		2150 m-days	\$1023.17

According to Carl Walker, the north door to the east patio was originally a window. Walker stated that he himself took the window out and put in the door. He said, "It did not change the appearance of the building, it just made it more functional."<sup>16</sup>

1949

#### Drafting Room Changes

In December of 1949, drawings were completed for the remodeling of the west drafting room located on the building's northwest corner. After new cabinets, partitions, and flat files were built, the room could accommodate up to ten draftsmen. Additional work tables, book shelves and cutting tables were also constructed. In 1950, plans were finalized for an addition to the drafting room to the north. Eleven more drafting tables were planned, but the addition was never built.

1956

#### West Basement Remodeling

In June 1956 plans were completed for the remodeling of the file room located in the west basement. After days of refileing plans, the files were organized in a small room in the south end of the basement. With the extra space available, a new office for the Civil Engineer, a spare office and a computer laboratory were built. The basement has not been remodeled since (Figure 46).

---

<sup>16</sup> Walker, Carl. Interview by Steven M. Burke, January 24, 1985.

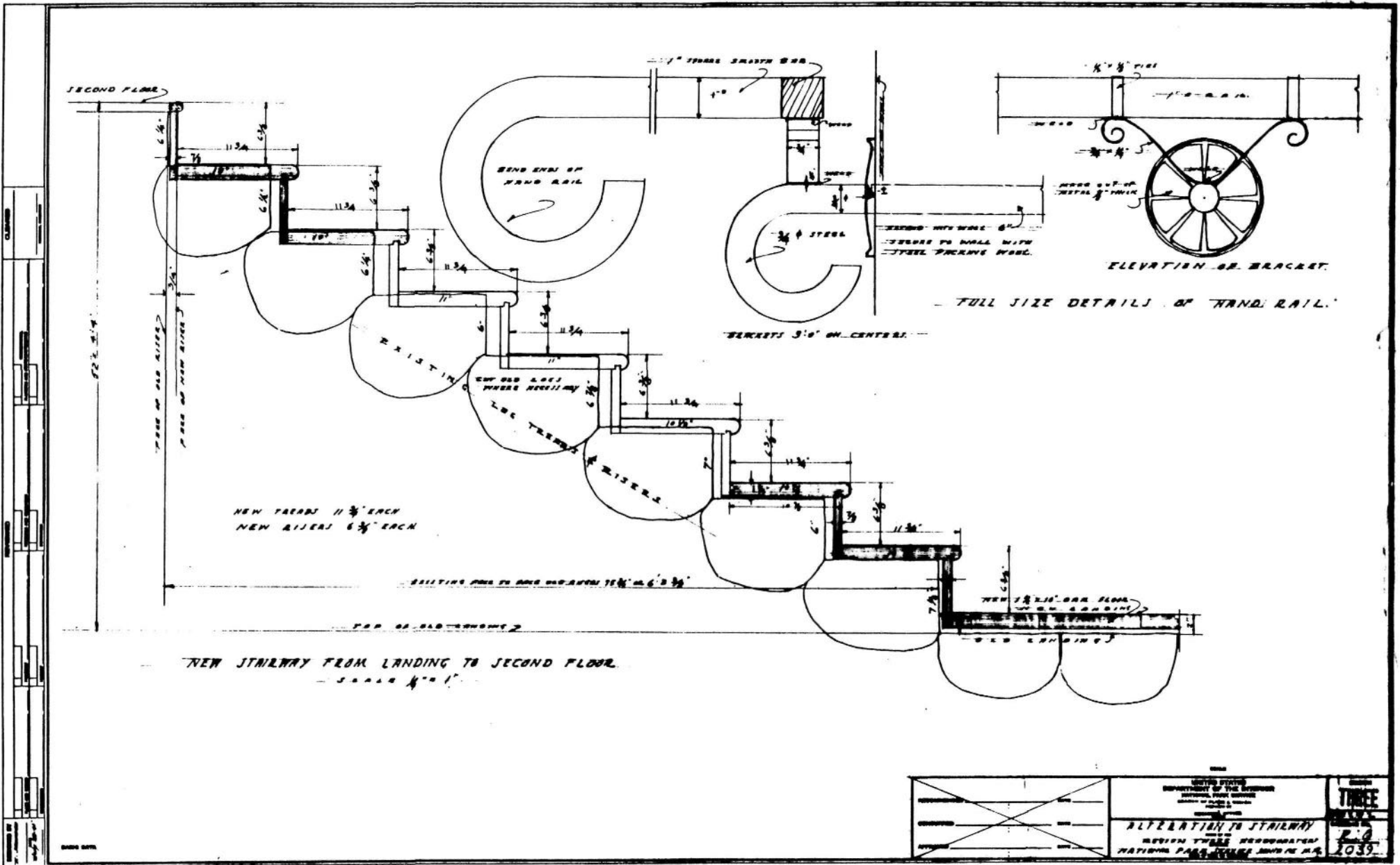

Figure 43.

Stairway alteration from landing to second floor and details of a proposed handrail.

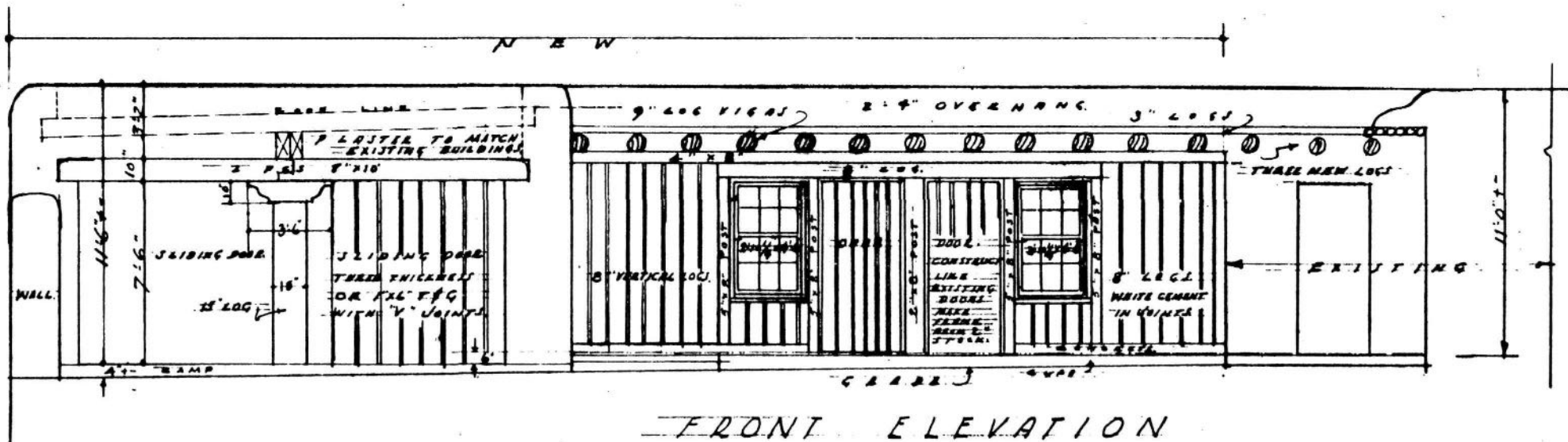

Figure 44.

The front elevation of the service building was constructed of 7-inch exposed vertical logs with chinking in between. This method of log construction is most common in the small towns to the north of Mountainair, New Mexico.

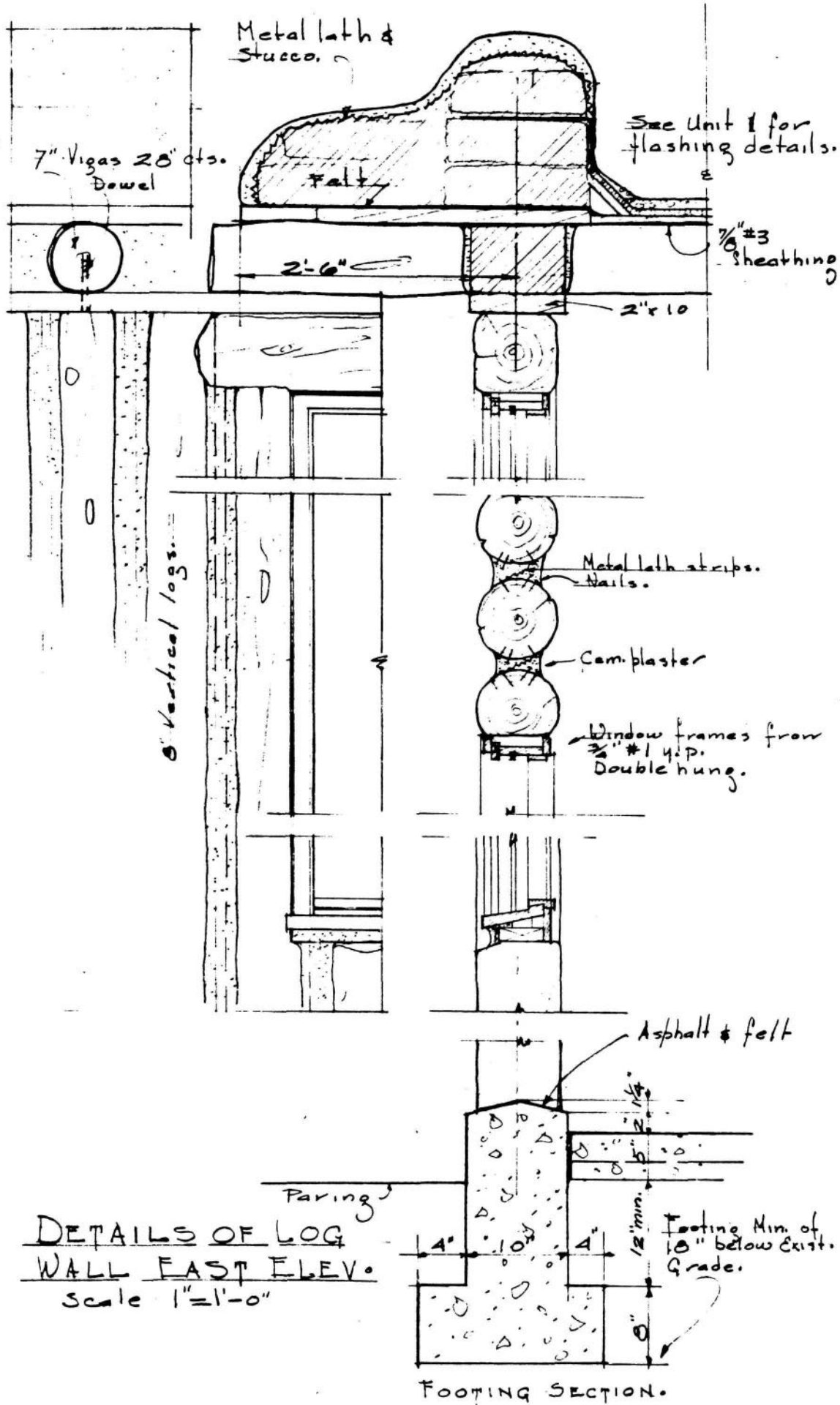

Figure 45.

The service building's east wall was constructed of 8-foot vertical logs, 7 inches in c' etc A 7 inch v... act... as a 'inte' above

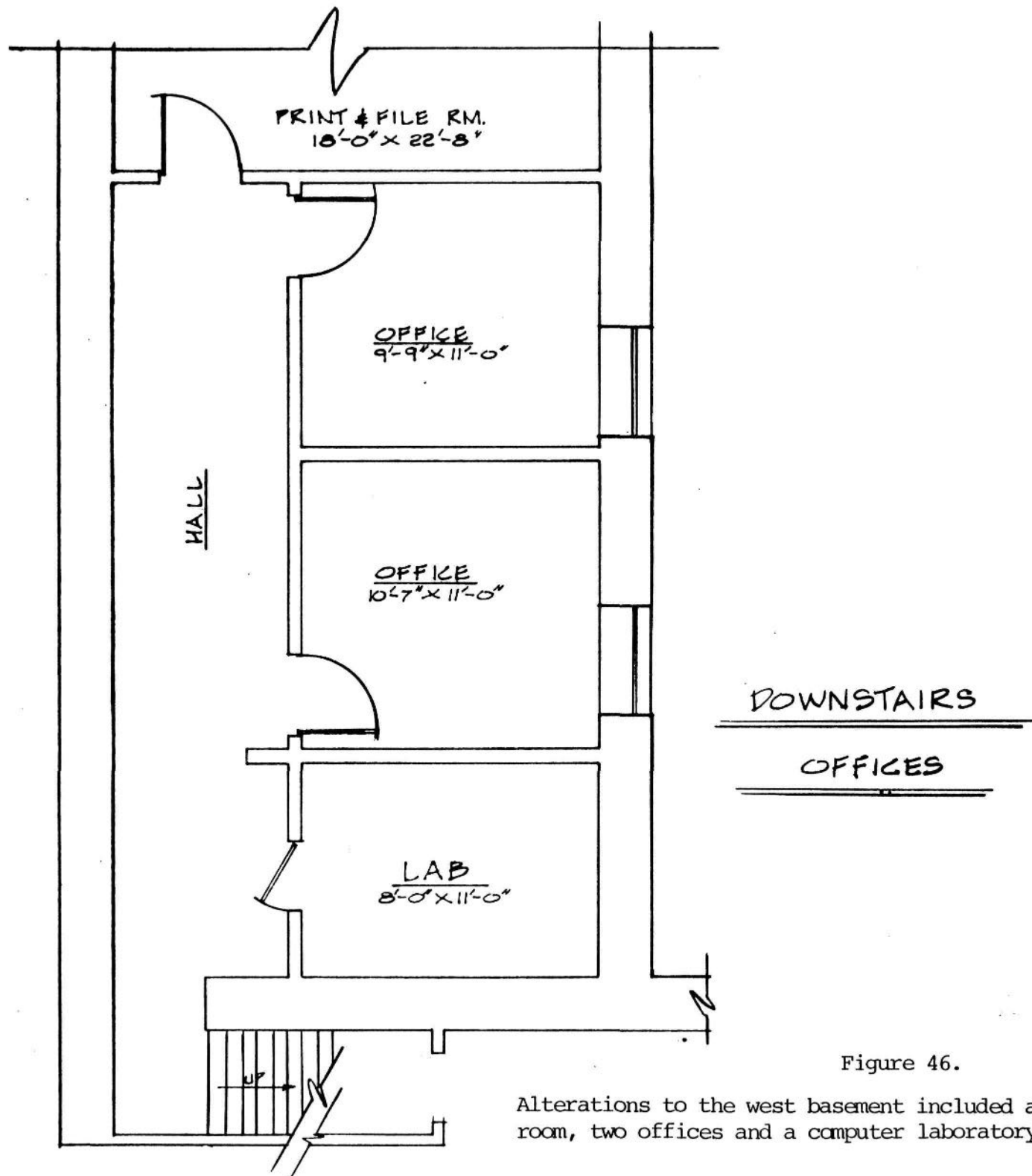

Figure 46.

Alterations to the west basement included a print and file room, two offices and a computer laboratory.

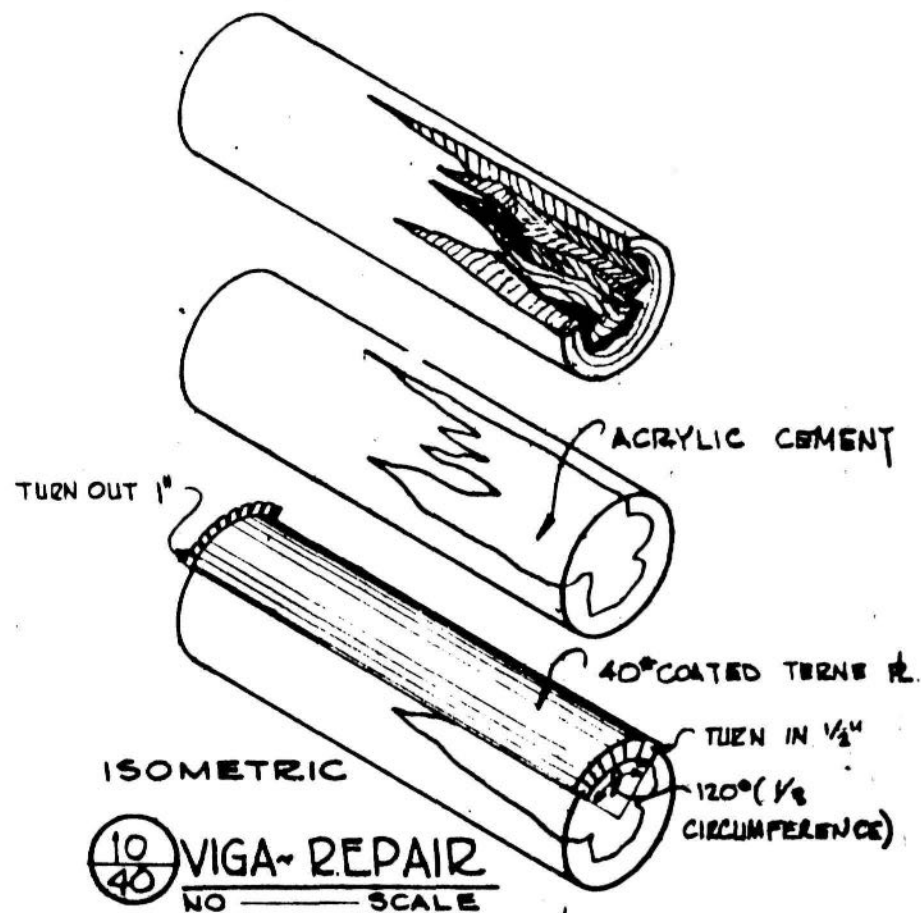
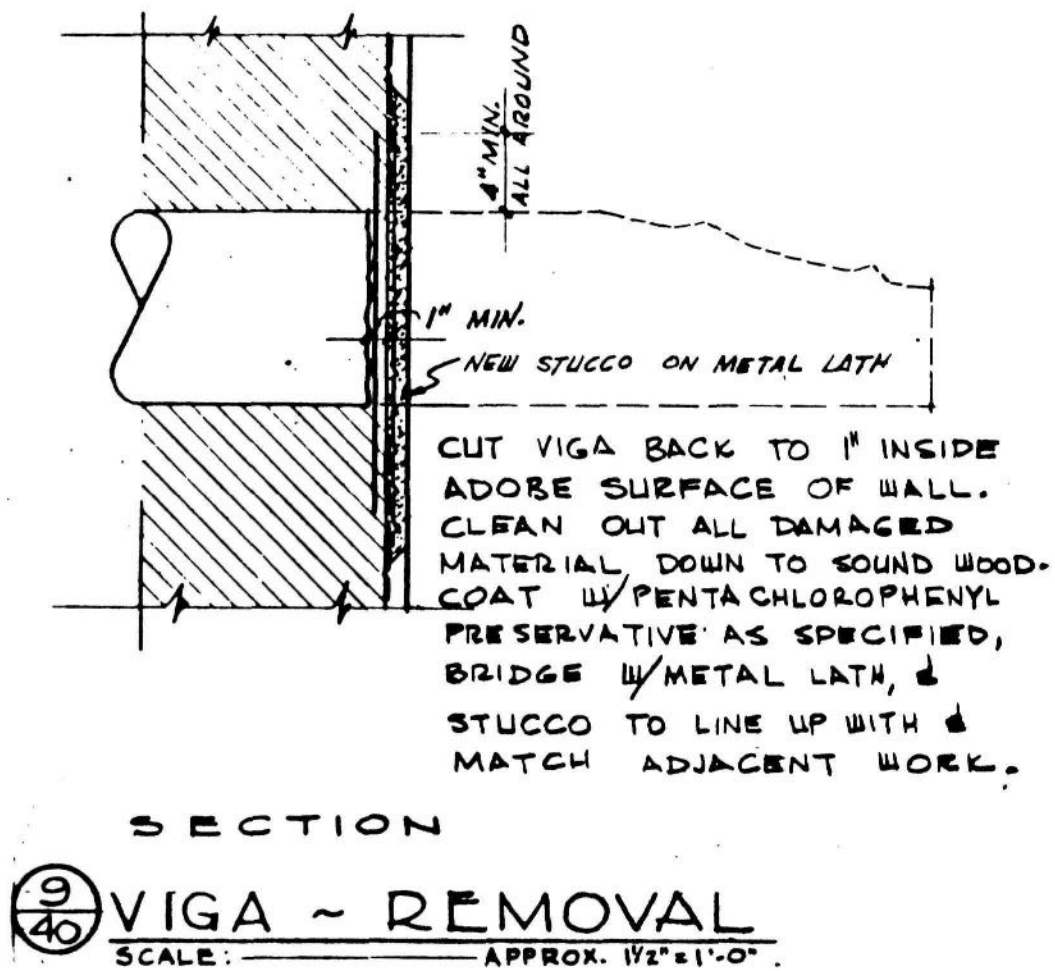

Figure 47.

The viga removal and repair plan shows many of the materials and techniques used when replacing vigas.

CHAPTER 5: ADDITIONS AND ALTERATIONS  
FROM THE 1960s TO THE PRESENT

1964

Service Building Alterations

In August 1964, alterations to Rooms 138, 139, and 140 in the service building had begun (for identification of rooms, see "Evolution of Spaces," Appendix A, Figures 55, 56 and 57). In Room 138 the existing concrete floors were patched and leveled and a set of double doors were removed. One of the doors was replaced with a window and the other with a single door. Metal lath and plaster was applied to the interior of the log walls, and existing light fixtures were replaced with new fluorescent tubes. New double outlets were also installed.

The ceilings in all three rooms were refinished leaving the exposed wood surfaces a natural color. An insulation and acoustical treatment was then sprayed on the ceiling between the vigas. All the plastered walls were painted "off-white." Ceiling-mounted gas heaters and vinyl asbestos floor tiles were also installed in each room.

An existing door between rooms 140 and 141 was plastered shut. Two solid doors on the building's north side were replaced with matching glass panel doors.

1967

Repairs to Vigas,  
Canales and Wood Posts

During the 1967 remodeling, half of the 209 vigas were in immediate need of repair or replacement. Where the exposed upper surfaces or ends of the vigas were in a severe state of decay, the rotted wood was removed and the viga was rebuilt to its original shape with an acrylic cement. After the cement had set, the viga tops were covered with a metal terne plate and cut back to a maximum projection of 2 feet. Of all the vigas repaired, only two were removed entirely. One of these was on the east side of the building and the other on the west side of the large patio. After the ends had been removed, the



remaining portions of the vigas were cut back to 1 inch inside the adobe surface of the wall. The damaged material was then cleaned down to the sound wood. A wood preservative called pentachlorophenyl was then used to seal the ends. Finally, the viga holes were bridged with metal lath and stuccoed to match the adjacent work (Figure 47).

During the remodeling, many canales on both the exterior walls and patio walls were in need of repair. This was accomplished by renailing the lining and filling the cracks in the wood with an acrylic cement like that used to repair the vigas. Many of the canales' flagstone lintels were removed entirely and the canales were rebuilt in the shape specified. The remaining canales also had the flagstone lintels removed, but these were rebuilt and reinforced as slotted openings. Two canales in the large patio were nonfunctional so they were removed entirely. The parapets around these two canales were rebuilt and new flashing was applied (Figure 48).

The wood posts on the large patio portal were undercut 1-1/2 inches high around the bottom and coated with a preservative wood sealant. The undercut part of the post was rebuilt to the original diameter with an acrylic cement. The undercut was finished with a pigmented wood stain to match the post above (Figure 48).

#### Wall Repairs and Painting

Prior to the 1967 remodeling, plans and elevations were drawn showing numerous cracks in the building's adobe walls. (Figures 49 and 50.) Many of the cracks ran in a horizontal direction and appeared to be on both the exterior and interior walls. Cracks which were 3/4 inch wide or less, with no adobe damage behind, were sealed with a 6-inch-wide fiberglass membrane. Those cracks wider than 3/4 inch, and with adobe damage behind, were cleaned out so that new adobe bricks could be added. If massive damage had occurred to the walls, all deteriorated or water damaged adobes were removed and replaced to the original contours of the building. After all repairs were done, new metal lath and stucco were added to match the adjacent walls.

After all the cracks and structural failures were repaired, the interior walls throughout the building were painted "cream," with the dado "terra cotta." Both colors were chosen to match the original paint. Also during the

SANDBLAST TO REMOVE ALL LOOSE & UNBONDED MAT'L. REBUILD WALL WHERE REQ'D & APPLY FABRIC 36" WIDE AS SPECIFIED. FINISH W/ ACRYLIC-FIBERED COATING AS SPECIFIED

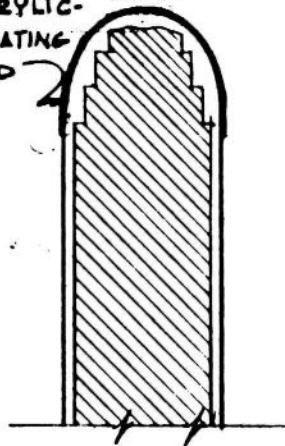

SECTION

$\frac{4}{40}$  CONFINING WALL~WATERPROOF  
SCALE: APPROX.  $\frac{3}{4}$ "=1'-0"

REMOVE EXISTING FABRIC & SAND BLAST TO REMOVE ALL LOOSE & UNBONDED MAT'L. REBUILD PARAPET WHERE REQ'D & APPLY NEW FABRIC 48" WIDE AS SPECIFIED. FINISH W/ ACRYLIC-FIBERED COATING AS SPECIFIED

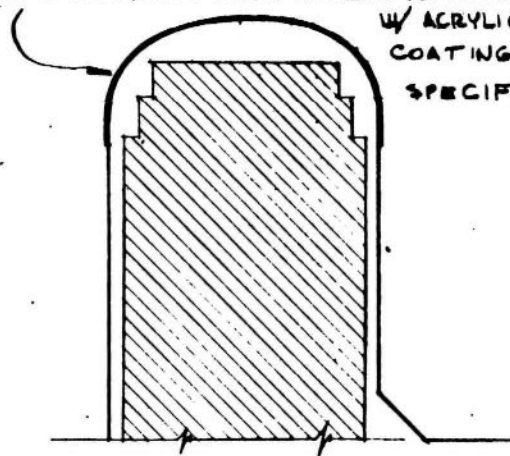

SECTION

$\frac{5}{40}$  PARAPET WALL~WATERPROOF  
SCALE: APPROX.  $\frac{3}{4}$ "=1'-0"

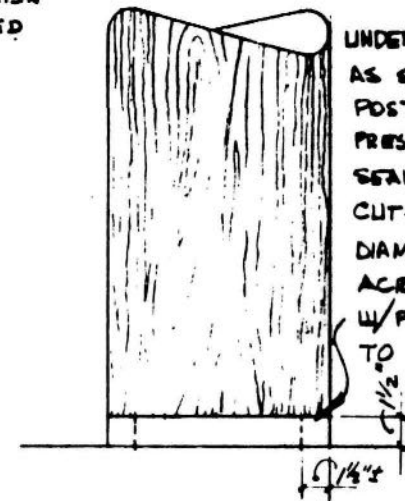

UNDERCUT POST ALL AROUND AS SHOWN. COAT ENTIRE POST & UNDERCUT W/ PRESERVATIVE WOOD SEALANT. REBUILD UNDERCUT AREA TO ORIGINAL DIAMETER OF POST W/ ACRYLIC CEMENT. COAT W/ PIGMENTED WD. STAIN TO MATCH POST ABOVE

ELEVATION

$\frac{6}{40}$  WOOD POST~REPAIR  
SCALE:  $1\frac{1}{2}$ "=1'-0"

Figure 48.

Parapet and wood post details show how the wood posts were undercut and rebuilt with an acrylic cement. Waterproofing of parapet walls was also done at this time.



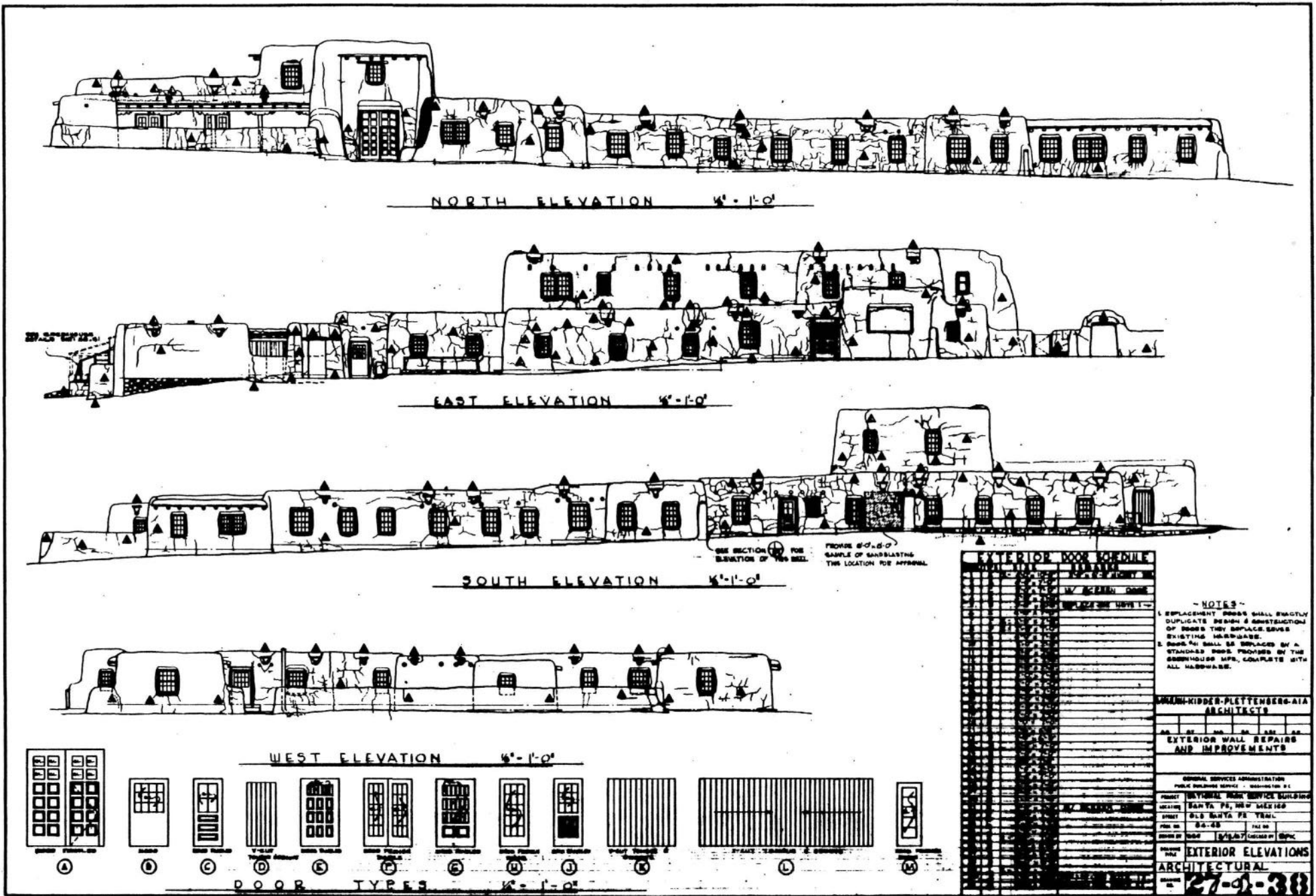

Figure 50.

Exterior elevation plans showing a number of exterior cracks. Also shown are a number of door types and an exterior door schedule.

original "cream" color. The cracks under the window sills on the second floor were filled, patched, and repainted the same "cream" color used throughout.

#### Windows and Doors

During the 1967 remodeling, all of the windows in the building were repaired or replaced according to one of the following specifications:

Remove and replace sash, frame and hardware; remove existing sash and repair, reputty and refit to frame; burn off the old paint seal, adjust balances and repaint; adjust or replace sash balances then sand down and paint.

Many of the wood windows on the second level were given one coat of "brown" paint to match the existing.

After the windows were repaired or replaced, window screens were added for summertime use. Screen frames were built of a local yellow pine and were designed to match the windows perfectly.

Many different window types were used in the building including: 12-light double hung, 16-light double hung, 12-light fixed, 1-light fixed, 2-light double hung, and an 8-light pivoted.

Like the windows, all doors that were replaced throughout the building were built as exact duplicates in design and construction as the doors they replaced. The existing hardware on both the doors and windows was reused. All the doors were refinished with the application of either one coat of "varnish" or "brown" paint. Door types common throughout the building include: wood paneled, v-cut, tongue and groove, and wood French doors.

#### Basements

The west basement was in need of minor repairs and maintenance during the 1967 remodeling. The plastered rock walls were given one coat of "cream" paint and the wood windows and convector radiators were given the same treatment as those on the second story. The doors were sanded down smooth and given one coat of paint instead of varnish. Few repairs were necessary in the east basement;

however, the stairs were rebuilt to increase the old tread width of 10-5/8 inches to 10-3/4 inches. Concrete stairs were poured directly over the old stairs, and the existing handrails were relocated higher on the walls.

#### Mechanical System

The building's mechanical system also required some minor additions. Five Krueger S 80 H.M. exhaust grilles and two Breidert Type F size 24 gravity exhausters were placed on the roof of the two-story portion of the building. The exhaust grilles have multi-louvered dampers and were constructed of steel with a grey baked primer coating. The grilles were centered between vigas so that none of the vigas needed to be altered. The attic exhausters, built of galvanized steel, have a 6-mph wind velocity and stand 10 feet high (Figure 51).

#### Service Building and Greenhouse Alterations

Minor repairs were done in the service building during the 1967 remodeling. All exterior doors and window frames were painted "brown" or a similar color to match the original. Many cracks on the south side of the building were also repaired.

During the service building remodeling, the existing greenhouse on the south side of the building was torn down and replaced with a smaller, more efficient one. The new greenhouse was built on the same foundation as the original, but displays a smaller, more compact design. The structure is 6 feet 10 inches wide by 19 feet 6 inches long. The original concrete wall, which serves as the foundation for the new greenhouse, was cut down approximately 1 foot, making the height of the new building lower than the original greenhouse. The current greenhouse has a continuous hinged vent 2 feet 4 inches wide running the length of the structure. The door is a standard product of the greenhouse manufacturer. In an interview on May 25, 1984, Frank Martinez, GSA maintenance worker, said that "the existing greenhouse is currently unused because GSA doesn't have the personnel to maintain it." (Figure 52)

#### Walls

Many of the perimeter and patio walls and building parapets were in serious need of repair during the 1967 remodeling. The walls were sandblasted,



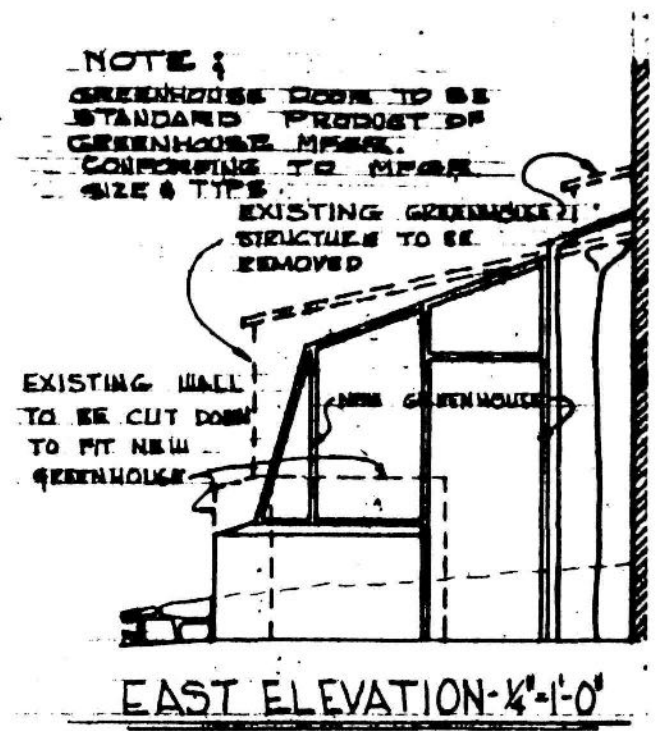
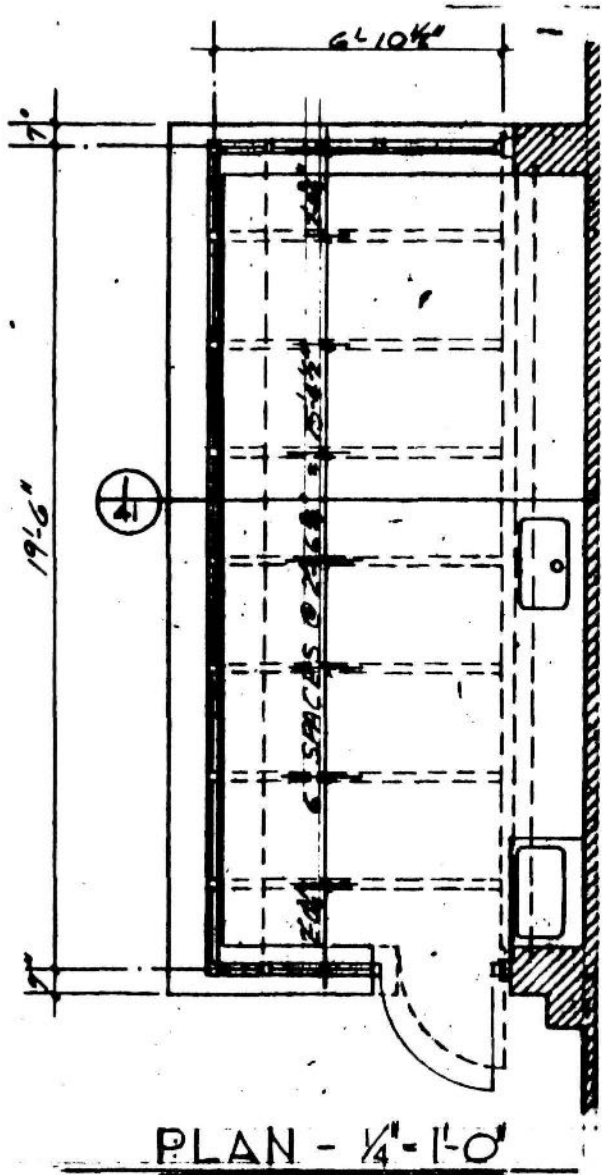

Figure 52.

Greenhouse details showing the existing greenhouse structure to be removed and replaced with a smaller more efficient one.



removing loose material, and were rebuilt where required. A 36-inch-wide fabric was placed over the adobe walls and that in turn was covered with an acrylic fibered coating.

1969

Portal Offices

During the remodeling, Rooms 109, 110 and 111 bordering the large courtyard, required minor changes (Figure 53,). In all three rooms, the door swings were changed to the opposite hand and new drywall partitions with 4 inches of batt insulation were added.

1972

In 1972 an upstairs bathroom was removed. Originally it was located in the northwest corner of the second floor near the Assistant Director's office. Early in the 1970s, space became critical and the bathroom was taken out and replaced with a duplicating room.

1974

Drafting Room

In 1974 drafting room partitions were added subdividing each draftsman's space. The partitions are constructed of a 2-inch by 3-inch wood frame with 1-inch by 12-inch planking on top. They stand 6 feet high, 3 feet of which is covered with burlap and used as a bulletin board. After the partitions were added, only five of the ten original drafting spaces remained (Figure 54).

1982

In 1982 the following handicapped modifications were made to the building: permanent ramps were constructed on the southeast corner of the large patio and on the building's east entrance. Temporary ramps have been constructed on both the patio restrooms and the northwest corner of the large patio. A permanent





ramp was also designed for the patio's northeast corner but as of this time has not been constructed.

---

- 17 Canal: A trough in a parapet wall for water drainage off a roof. In New Mexico, canales (the plural form) are traditionally made from hollowed-out vigas.

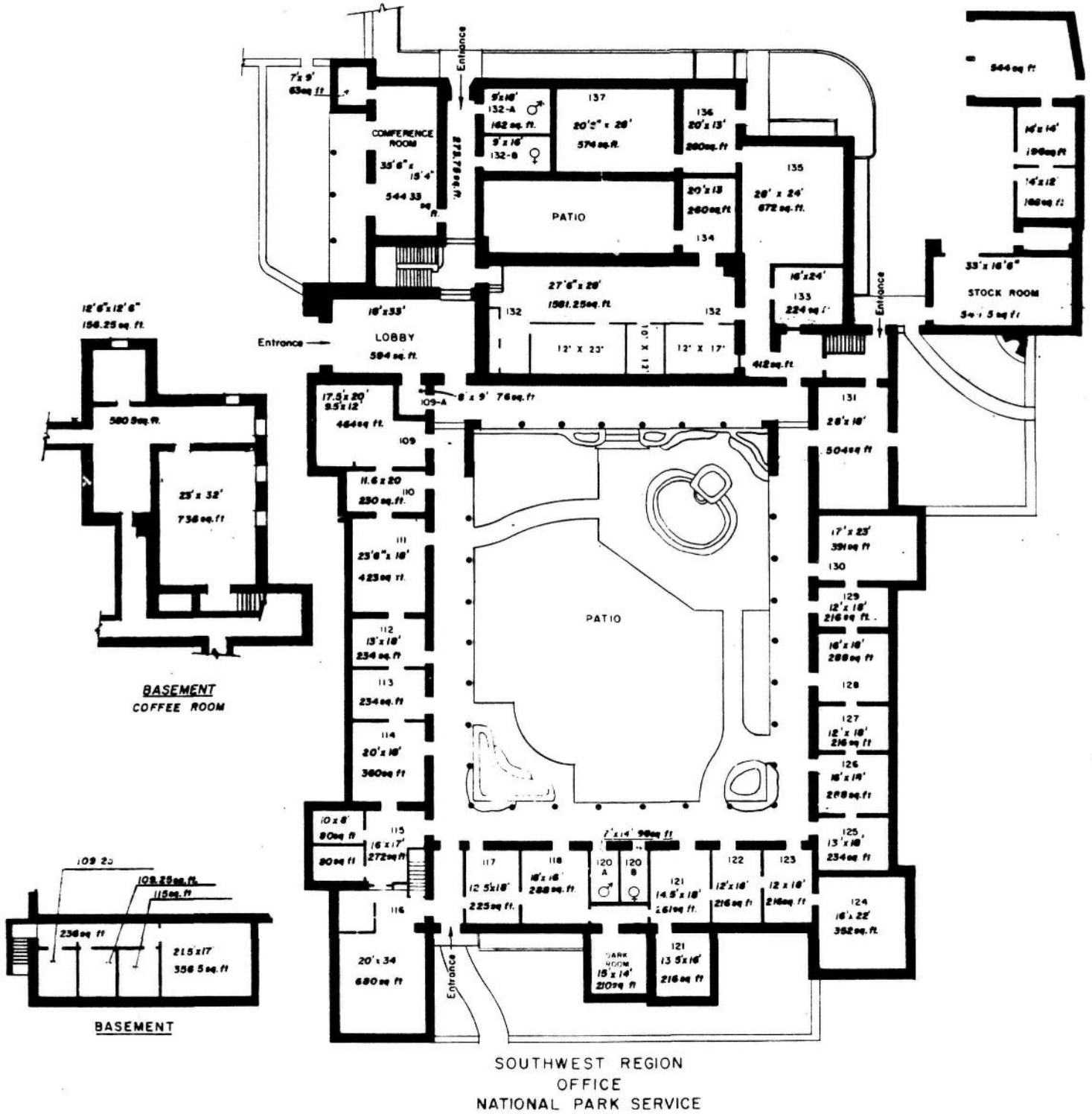
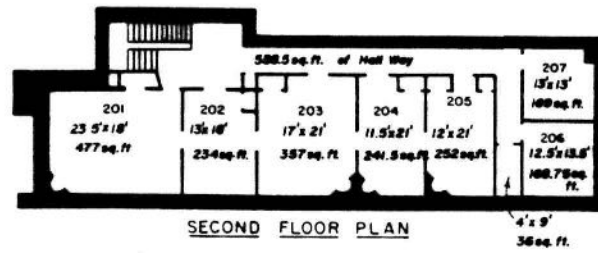

Floor plans showing the dimensions and square footage of each space.

## RECOMMENDATIONS

The National Park Service Southwest Region Office Building is listed on the National Register of Historic Places, the nation's inventory of structures significant to America's cultural heritage. Therefore, any action affecting the structure--whether beneficial or adverse--must meet standard compliance requirements as mandated by the Historic Preservation Act of 1966 with Amendments (Section 106). The actions include simple, routine maintenance such painting or minor repairs, as well as major cyclic projects, such as reroofing, replacement of heaters, and other maintenance items.

Any major changes proposed for the building must first be carefully assessed before permission to proceed will be granted. Examples of this type of major alteration are: adding or removing partitions, cutting in, enlarging, or blocking up door openings, changing the size of rooms, installing detection or intrusion alarm systems. The National Register listing also covers historic items contained in the building, such as furniture, and elements affixed to the structure, such as hardware and lighting fixtures. Therefore, any changes proposed to these items also require clearance.

To make this compliance easier, the National Park Service has a unique agreement that shortens the process. This is the "Programmatic Memorandum of Agreement" (PMOA) procedure, more simply known as "XXX" (triple X). Under the PMOA process, the individual or agency considering any alterations to the structure completes the short XXX form, giving the following information: the exact nature of the work proposed, the effects the work may have on the structure, and the measures which will be taken to lessen, or mitigate, the effects.

Examples of Architectural  
Elements Warranting Preservation

- Shape and plan of the building and site
- Room size and configuration
- Defined exterior spaces such as patios and portals

- Adobe walls
- Wood members, e.g., posts, corbels, vigas, latias
- Canales
- Built-in elements, including bancos, shelves, and niches
- Fenestration (configuration of doors and windows in the walls)
- Doors and windows--their hardware, finish, and glazing
- Electrical fixtures, ranging from chandeliers and other light fixtures to switch plates
- Floor materials and finishes (whether wood, flagstone or other)
- Wall size, shape and configuration in patio, parking lots and throughout the site
- Shapes of parking lots, planted islands, and other landscape architectural aspects of the site
- Sidewalks and curbs--materials, shape, configuration, and color

#### Current Maintenance Items

Following is a listing of maintenance items which GSA proposes to undertake on the Southwest Region Headquarters Building beginning in Fiscal 1985. The items are in priority order and are categorized according to type, as follow:

B--Items to be done by contract. Plans and specifications subject to approval by the National Park Service (portions provided by NPS); ongoing spot inspections, final inspection and approval by National Park Service. Historical fabric repair assistance by National Park Service.

C--Work to be done by certified specialists (electricians, plumbers, etc.). Final approval by the National Park Service.

D--Routine work by local GSA maintenance; final approval by National Park Service.

Priority Maintenance List

<u>Priority</u>	<u>Type</u>	<u>Description</u>
1.	C	Room B-04 - Recaulk joint above 4-inches cross in sewer line above doorway. Consider removing 4-inch riser and plug line instead.  Check and recaulk joints in fittings under ceiling in plan room also.
2.	D	Improve Road Sight Distances - Remove brush and Chamisa for 100 yards along south edge of Old Santa Fe Trail on each side of entrance. Remove Chamisa around entrance. Remove trees, limbs and Chamisa between pavement and guard posts on road to rear parking lot, both sides of road. Prune trees around both parking lots to preclude scratching paint on vans. Prune or remove trees on entrance drive (west side).
3.	D	Install storm windows on all remaining windows - 87. Energy conservation.
4.	D	Room 116 to Basement - Replace Lightguard battery.
5.	D	All windows - Replace/repair window locks for immediate security.
6.	C	Patio brick walks - Reset brick edgers down flush with top of walk and stabilize in place. Resand all joints.
7.	D	Room 137 - Reset loose electrical switch box (120/240V) and outlet for A/C on wall. <u>Replace broken window pane.</u>



8. C Patch and seal stucco cracks - exterior walls.
9. B Rehab darkroom for computer, A/C, ventilation, soundproofing, 3-phase power.
10. C Room 116 - Install 110/240V outlet in wall to serve drafting table outlets (now on cable).
11. C Small east patio - Repoint walk, mortar; replace/repair windowsills.
12. D Annex crawl space door - Repair and install door on hinges and a catch.
13. D North Entrance - Replace stucco paint on exterior wall above doorway.
14. D Pavement - seal cracks.
15. B Roofing - Heated areas - 19,400 S.F.  
Portals (Porches) 4,350 S.F.  
Specs available from DSC/OM.

We feel the heated areas should have a minimum of 4-inches insulation and the remainder 2-inches. We recommend all areas be stripped, any wet areas dried, patches made as required, all flashing repaired and new roofing installed.

Recommended roofing systems should be:

a. Sprayed foam w/50 mil colored top coat U-66 system, estimated at \$4/S.F. with a 10-year plus 10-year guarantee.

b. Elastomeric single-ply membrane, Carlisle Universal Design (Carlisle Tire and Rubber, 800/233-0551), estimated at \$7/S.F. w/20-year warranty.

16. D Entrance Sign - repair and repaint. Fix stucco cracks. clean sign and seal, paint frame.
17. B Repair/replace vigas - cut and drill out all rotted exposed viga ends to 6-8-inches into exterior walls. Replace with CCA treated butts trimmed to fit holes. Exposed diameters to be 1-inch larger than hole diameters. Butts to be doubled doweled, epoxied and sealed.
18. C Mortared brick around fish pond - reset/repoint loose bricks.
19. D Rear Parking Lot - Replace spalled concrete bumper blocks and install new ones where missing. Mark 2 stalls by tree for small cars.
20. D Non-draining drain pipes - North Entrance walk and road to rear parking lot - hand dig ditched to daylight.
21. B Pavement - inspect, seal cracks, install tack coat and overlay all pavement with 1-1/4 inch asphaltic hot mix. Repaint parking stall stripes and centerline in roads.
22. B Front lobby, large historical door to inner patio - repair/remove gouges, scars, patches, sand and refinish. Repair door lock mechanism. Replace door closer with one matching hardware/or paint black.
23. B All doors and doorways - repair/replace frames, handles, door stops, hinges, thresholds, locks, weatherstripping, reglaze loose glass or reset wood frames for glass lights. Refinish doors and check doors for closure and seating.
24. B All windows and window frames - same as above.

25. C Telephone cables draped on floors - arrange with Bomur to reroute/reattach cables to walls or under floors.
26. C Room 124 - Replace broken missing bullnose tile on steps. Install 120/240V electrical outlets.
27. C Fish pond in patio - remove goldfish to safe tank, drain, clean and waterproof pond walls, floor. Cure and flush pond, test and reinstall fish. Wasting water as the pond is now.
28. D Front lobby, light over Mather portrait - remove tape and install plastic caps at splice in wire.
29. D All restrooms - grind faucet valve seats, replace washers, tighten stall dividers, clean/repair exhaust fans, tighten/replace stall door locks, install escutcheons where missing, re-grout tile.
30. D All rooms - finish/touch-up installation of wall heaters. Replace floor tile - west Xerox room.
31. D Grounds within boundry - remove paper, bottles, cans, piles of old concrete, old boards, glass, metal, plastic, etc. Clean out airwell by west door. Discontinue use of and cleanup dump sites over east compound wall.
32. D Most rooms - repair carpet around newly installed heaters.
33. D Reglue/replace vinyl baseboard tile.

34. D Room B-01 - Replace ceiling panels where missing or warped. Ditto light fixture diffusers. Paint plywood window panel - both sides.
35. D Room 116 - Paint base for new water cooler and wall behind cooler blackened by torch.
36. D Room 128, south exit porch - Reset stone step and remove old flagstone pieces of walk beyond.
37. D Room 130 - Reset loose multi-outlet strip (120/240V), west wall.
38. B Restore columns, posts, beams, etc., to original finish (remove latex stain, etc., and apply boiled linseed oil).
39. D Hall 201 - Install escutcheons on pipes to water cooler. Scrape, sand, and paint window sills - both wood and plaster.
40. D All second floor rooms - Scrape, sand and paint window sills - wood and plaster both.
41. D Room 203, closet - Paint black patch and rust stains under lavatory.
42. D Greenhouse behind Annex - Remove old wooden fence section on west end. Patch stucco to match where post will be removed. Install cover on old V.C. tile box or remove tile if valve is dead. Cover hole in greenhouse roof.
- (Use for storm window storage)?
43. D Boiler Room Annex - Cleanup trash, install light bulb and tag main water shut-off valve.
44. D Boiler room Crawl Spaces - Clean out trash and junk.

45. D Add directional sign and wrench for main gas shut-off valve which is located at the meter out by the street.
46. D Accelerate cleaning program to include rug vacuuming weekly and cobweb removal occasionally.

#### Treatment Recommendations

##### Roof Replacement and Parapet Repair

The structure is in need of a new roof, and the recommended roofing system is:

Elastomeric single-ply membrane, Carlisle Universal Design (Carlisle Tire and Rubber) estimated at \$7.00/square foot with 20-year warranty. Refer to item 15 on the Priority Maintenance List for additional information.

Repair cracks in parapet walls and seal. Replace any adobe units as required.

##### Repair of Wood Members

The work described below includes repair/replacement of canales, vigas, exterior latias, columns, lintels, windows and doors. Methodology is based in part on that developed for Bandelier National Monument by Randall Copeland, Denver Service Center.

Canales: The proposed work will consist of removal of the roofing system as required (including deteriorated sheathing) and installing metal-lined (lead-coated copper), CCA-treated and stained canales to match the originals. The metal will extend over the sheathing and parapets to ensure proper flashing.

The number of canales to be replaced will be determined following on-site evaluation.

Viga Repair and Replacement: The technique proposed is that developed by Dr. Harrison Goodall of Conservation Services, Inc. and has been used in a number of similar NPS projects. The work will consist of removal of all deteriorated

wood, application of a low-viscosity consolidant to the existing vigas, and installation of new stubs. All exposed ends will be adzed to match the original character of the vigas. The juncture of new wood with old will occur approximately 2 inches beyond the wall face except where the decay extends further. A clay and sand mortar similar to the original will be used to fill any voids between the log and masonry. The new wood, CCA-treated and stained, will be joined to the original wood by fiberglass rods set in structural epoxy. This method will be used on all deteriorated or missing vigas at locations to be determined following an on-site evaluation.

The original vigas will be retained unless they cannot be repaired or are structurally unsound. Methods for stabilizing and preserving the vigas shall have been determined before replacement is made.

Issues for consideration prior to replacement:

1. Is the entire viga decayed?
2. Are only the viga ends decayed?
3. Will the viga decay further if it is prevented from coming in contact with water?
4. Do the viga ends have terne plates? If so, should they be removed?
5. Can the viga be repaired by epoxy?
6. Is there another method of correcting the problem? (Goodall and Friedman 1980:40)

Refer to Chapter 5, "1967 Repairs to Vigas, Canales and Wood Posts."

Epoxies: Epoxies are used often to solidify the decayed matter in wood, and to patch holes left by decay. They prevent further decay, but do not return a deteriorated log to its original condition. Epoxies are resistant to both insect infestation and adverse weather conditions. A viga does not need to be removed to apply the epoxy, as the work can be done in place (Ibid.).

If viga replacement is imminent (i.e., the viga is so severely decayed it cannot support weight), then a replacement log must be prepared. Preferably a

new viga or viga end will match the original in size, species and shape. If possible it should be hewn or debarked. Once a new log has been selected, refer to item 17 on the Priority Maintenance List for replacement technique.

Removal of Paint from Posts and Corbels: The posts, viga ends, and corbels in the main patio portal remained in their natural unpainted state for more than 30 years. About a decade ago, GSA was instructed to paint them a dark, non-historic brown. Frank Martinez recollected that this was to cover a "redwood" color stain, which had proved to be too red. The wood members were repainted in the same dark brown two or three years ago (Frank Martinez, interview with Marlys Bush Thurber, May 30, 1984).

Tests were conducted by Marlys Bush Thurber, Frank Martinez and Leon Hernandez on removal of paint from the posts in the main building portal:

The testing was prompted by the need to determine whether to retain the painted surfaces, or to restore the portal to its original appearance (a natural stain), prior to contracting for the restoration and replacement of deteriorated vigas and canales.

Two paint removal methods were tested: an electric heat gun and a chemical remover. Mr. Martinez initially expressed concern that the underlying stain had penetrated so deeply that neither method would remove it. However, in a matter of seconds the heat gun removed both paint and stain down to bare wood in the 6-inch square test patch. The chemical remover, "Strip-Ease," was less successful. The liquid was applied and allowed to penetrate for a short period, and the test area was then scraped with a manual scraper. Using this method, paint removal was uneven, and the process was longer and took more effort than the electric heat method.

In conclusion, the electric heat method appears to be a sound approach to removal of the painted surfaces, should we determine to restore the portal to its original appearance. It should be noted, however, that some of the posts have been patched extensively with a white patching compound, which would be visible no matter what method were employed. This compound would have to be removed and replaced with a filler

which more closely matches the finish stain (Marlys Bush Thurber to Associate Regional Director, May 30, 1984).

Based upon the available historical information (see figure 27, a photograph which shows the patio's appearance shortly after the original construction), and the success of the paint removal tests, it is recommended that the posts, viga ends, and corbels be returned to their historic appearance. However, other factors, such as the need for treatment with a CCA preservative, may make this recommendation infeasible. All factors shall be weighed before a final decision regarding removal of paint is made.

Any paint removal should be carried out immediately prior to or concurrent with the repair work planned for these wood members.

The following procedures should be used:

1. Remove paint with electric heat gun to bare wood.
2. Replace non-matching wood filler with a natural wood filler.
3. Do not put nails, screws or any other hardware on historic fabric.
4. Repair/replace column bases where required.
5. Remove dark stain on window and doors and restore to original color.

Possible Replacement of Portal Posts: Prior to or during the paint removal work, inspect all posts (columns) for deterioration and possible replacement. Any posts which cannot be repaired will be replaced in-kind. The number of posts to be replaced will be determined during on-site inspection.

#### Outbuildings

##### Service Building

Although the service building is in good repair, it requires routine maintenance and minor repairs. The structure should be inspected and the need for the following repairs assessed:



1. Repair/replace daubing on vertical logs.
2. Repair/patch stucco on exterior.
3. Reroof building. Refer to item 15 on the Priority Maintenance List for methods and recommended roofing system.
4. Repair/replace viga ends, including application of wood preservative (refer to viga repair section in Recommendations).
5. Doors
  - a. Repair/replace door frames when required. Duplicate original.
  - b. Repair/replace hardware, thresholds, door stops and weatherstripping.
  - c. Reglaze loose glass or reset wood frames for glass lights.
  - d. Refinish doors where required. Duplicate original color. Reuse all original hardware
  - e. Check doors for proper closure and seating.
6. Treat all windows and window frames the same as the doors. Reuse or duplicate window hardware. Refer to Appendix E.
7. Repair plaster (interior) and repaint where necessary.
8. Repair/replace plumbing if required.
9. Repair electrical if required.
10. Remove sprayed on ceiling insulation from exposed vigas. Restore to original appearance.
11. Perform routine maintenance to prevent further decay.

Greenhouse

The proper use of the greenhouse needs to be determined, with consideration given to the restoration of its historic use. From a maintenance standpoint, the structure requires basic upgrading and repair.

1. Clean structure thoroughly including the glass, fixtures and sink.
2. Repair hardware (window and doors).
3. Repair mechanical system.
4. Check plumbing.
5. Repair/replace planting benches.
6. Repair stucco and repaint where required.
7. Repair holes in roof.

If the building is to continue to be used as storage, repair/replace materials to prevent further decay in case of future reuse.

#### Doors and Windows

Repair/replace door and window frames where necessary. Take care to duplicate frame design, color and materials. Reuse all door and window hardware or duplicate.

Install storm windows designed to match existing storm windows in material, hardware and finish. Refer to items 3, 23 and 24 on the Priority Maintenance List for more information.

Remove fiberglass or fabric mesh from window sills. Repair/restucco affected areas.

#### Hardware Replacement

All door, window, and gate hardware shall if at all possible be cleaned and reused. If replacement is necessary, new hardware must be an exact duplicate of the original. Sources for replacement hardware are listed below.

Replace olive knuckle hinges with Stanley hardware:  
Forged bronze 6 inch by 3-7/8 inch  
Use hot-dip oil process to achieve black color

Replace ball hinges with Stanley hardware:  
Heavy weight 4-1/2 inch and 5 inch  
Standard weight 4-1/2 inch and 5 inch  
Ball tips are solid brass  
Two ball bearings are visible  
Use hot-dip oil process to achieve black color

Replace entrance sets with Sargent architectural hardware:  
7-3/8 inch by 2-1/4 inch overall  
Escutcheon: wrought iron  
Knob: wrought--hot-dip in oil to achieve black color  
7700 and 18-7700 Models  
MRL-M2 Models

Replace window sash hardware with Ives Company hardware:  
Window sash crescent type lock No. 9--Model Nos. 9F, 18A, 9MB19  
Finish: dead black

Replace window sash lifts with Hager Company hardware:  
4-5/8 inch by 1-1/8 inch  
#1489 bar type  
Steel: Use hot-dip oil process to achieve black color

Replace screen door pulls with Ives Company hardware:  
#410 A19  
#410 B19  
Finish: dead black

Replace entrance sets with Yale hardware:  
#DY80  
#D280  
Plate finishes: satin black ebony  
  
#315 693, black (USID, DY80)  
#315 693, black duranodic  
Sprayed finishes

Note: Measure existing fittings to ensure proper size for replacement items.

### Ceilings

Ceilings should be cleaned, repaired and repainted where necessary. Vigas should not be nailed, cut, or altered in any manner. Vigas and corbels should be restored to the original finish. Exposed vigas should never be covered by suspended structures or coated by spray acoustical materials. Ceilings with missing or broken materials should be replaced using duplicate materials.

### Confining Walls

Patch and seal stucco cracks on all confining walls. Replace adobe units where required.

### Parking Areas

Seal cracks in pavement, repaint parking spaces where required. In the rear parking lot replace spalled concrete bumper blocks. Mark two stalls by tree for small cars. Refer to item 29 on the Priority Maintenance List for further information on pavement repair.

### Landscaping

Many of the trees, shrubs and ground covers were originally planted when the building was constructed in 1940. Numerous plants were saved, including chimisa and pinons, and these should be cared for in the same manner as a historic artifact. Other than routine maintenance, i.e., trimming, watering, fertilizing, the landscape elements should not be moved or harmed unless absolutely necessary.

### Pool and Fountain

Although the pool and fountain are in good repair, routine maintenance should be done to keep the pool clean and pleasant to look at.

The pool should be periodically cleaned by draining the water and should be waterproofed. Any loose stucco should be repaired, along with loose or missing brick pavers and adobe bricks.

#### Large Patio

1. Repair pool and fountain as previously stated.
2. Reset brick pavers around pool and fountain and brick walks. Refer to Chapter 3 for photos showing original location of walks, etc. Refer to item 6 on the Priority Maintenance List for further information.
3. Prune trees and shrubs where required, but do not remove.
4. Repair/replace adobe and/or stucco on bancos.
5. Routine maintenance on grass areas including: mowing, trimming, watering and fertilizing.
6. Repair loose flagstone on portal floor if required.

#### Building Grounds

Remove trash. Refer to item 31 on the Priority Maintenance List for more information.

#### Furniture

The furniture and fixtures throughout the building are protected by the structure's listing on the National Register of Historic Places. They must be accorded regular inspection and maintenance, and special curatorial care when required.

1. Check furniture for any loose parts, such as stringers and rungs.
2. Examine furniture for any labels or handwriting. If anything is found, record it.

3. Record any elements that are broken or missing.
4. For all painted furniture, check for flaking or lifted paint.

#### Cleaning Dirty Furniture

Dirt on a piece of furniture can be a hazard to the surface if it is allowed to accumulate. Dirt builds up an abrasive residue and attracts and holds moisture if the humidity is high.

If a piece of furniture is very dirty, it should be lightly vacuumed over before heavy cleaning or restoration.

For furniture with grime from normal handling use the following method:

1. Test the finish with various cleaning liquids on an inconspicuous area of the object using a cotton-tipped applicator. If the cleaning liquid is sufficient, the applicator should pick up the dirt without removing the finish.
2. If the test liquid proves safe, fill a bucket with distilled water and add one teaspoon detergent to each gallon of water.
3. Remove dirt with a damp sponge (almost dry). After an initial cleaning repeat process with a clean dampened sponge.
4. Dry the piece off with soft cotton towels.
5. Repeat process again and again with a sponge wrung to almost dry. This should remove any detergent residue left on the furniture from the cleaning process.

If repair is required on such elements as rungs, stringers and chairbacks, it is imperative that the elements not be modified or reattached with nails or screws if these fasteners were not originally used.

1. Use hide glue for reattaching elements.
2. Use original nails or screws for reattaching loose elements.

If joints have separated the following procedure may be used:

1. Use a hot hide glue (for extra strength).
2. If element is entirely separated, do not remove old glue. Soften it with water (it may be necessary to maintain the spacing created by the old glue).
3. Pad the area where clamps will touch the object.
4. Apply glue to joint, wipe off excess and clamp the joint together. After clamping remove any glue which may be pressed out.
5. Let the glue dry for 24 to 48 hours before further restoration.

#### Repairing Surface Scratches

Minor surface scratches can often be repaired by simply rewaxing. Slightly deeper scratches can also be removed or reduced by rewaxing.

Wax polishes should be applied with a soft cloth, then buffed with a clean cloth. Make sure that the colors match. Refer to Chapter 2 for original furniture finishes and colors.

#### Fixtures

##### Light Fixtures

The light fixtures, covered by the National Register listing, also require maintenance and treatment as historic artifacts. Care must be exercised when cleaning or repairing the fixtures.

If replacement is unavoidable, an exact duplicate must be obtained. This will likely be costly, as the lighting fixtures are handmade and one-of-a-kind.

All new, non-historic fixtures including fire control devices, incandescent fixtures and telephone lines must be placed in inconspicuous areas. Wires and cables must also be located in inconspicuous areas, never nailed or stapled to exposed vigas or other historic fabric.

Switch covers and outlet covers must be duplicated to the exact dimensions of the originals. Place new light switches and outlets at the same height as existing ones. (Refer to Chapter 2 for details.)

#### Interior Walls

Repair all cracks in plaster on the walls and ceilings. Repaint where necessary with an approved paint. Duplicate the original colors. Walls should be cleaned thoroughly before applying the paint, as the paint will not adhere readily to chalked or dirty surfaces.

#### Floors

Flagstone floors are to be sealed every 6 months with a varnish floor sealer. All carpeting is to be vacuumed and cleaned frequently to ensure extended wear. Any holes or tears shall be repaired.

All loose vinyl tile and baseboards shall be reglued or, if necessary, replaced. The original tile design and color shall be duplicated.

#### Restrooms

1. Repair or replace any loose ceramic tiles. Duplicate original.
2. Tighten stall dividers in both the floor and walls. If hardware replacement is imminent, the original hardware should be duplicated.
3. Repair any leaky faucets, running toilets and soap and towel dispensers.
4. Enlarge one stall in each restroom to allow for handicap accessibility.

Refer to item 29 on the Priority Maintenance List for further recommendations.



Foundations

Check foundation on both the exterior and interior (where exposed) for loose rock or mortar. Replace rock where required and seal any holes. Repoint (mortar) if needed.

GSA may wish to refer to the book, Cyclical Maintenance for Historic Buildings, by the Office of Archeology and Historic Preservation, National Park Service, U.S. Department of the Interior.

## APPENDIX A

Evolution of Spaces

Since 1938 the evolution of offices has changed considerably, but not to as destroy or alter the building's original appearance. The following three floor plans illustrate how many of the departmental offices have changed since 1938.

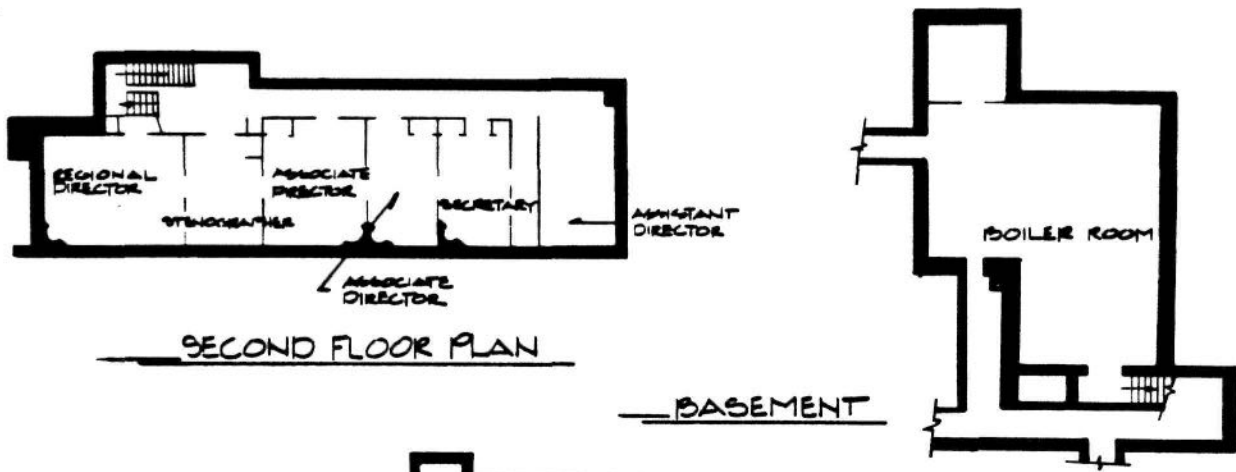

**EVOLUTION OF SPACES  
1938**

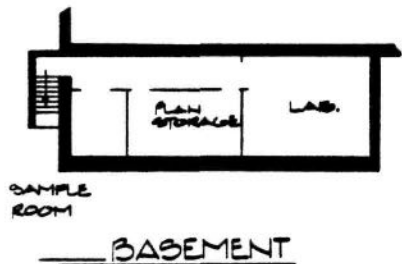
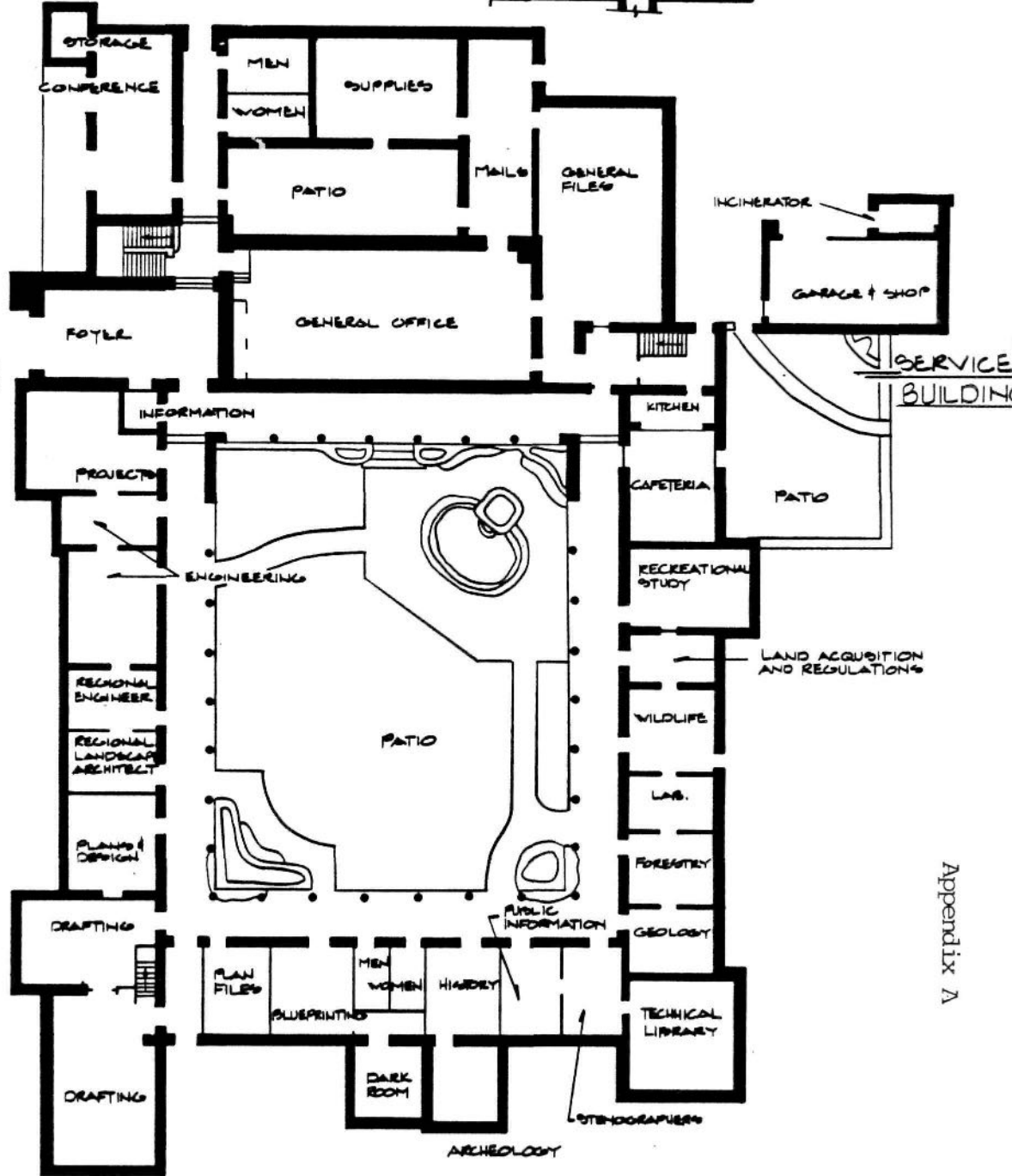
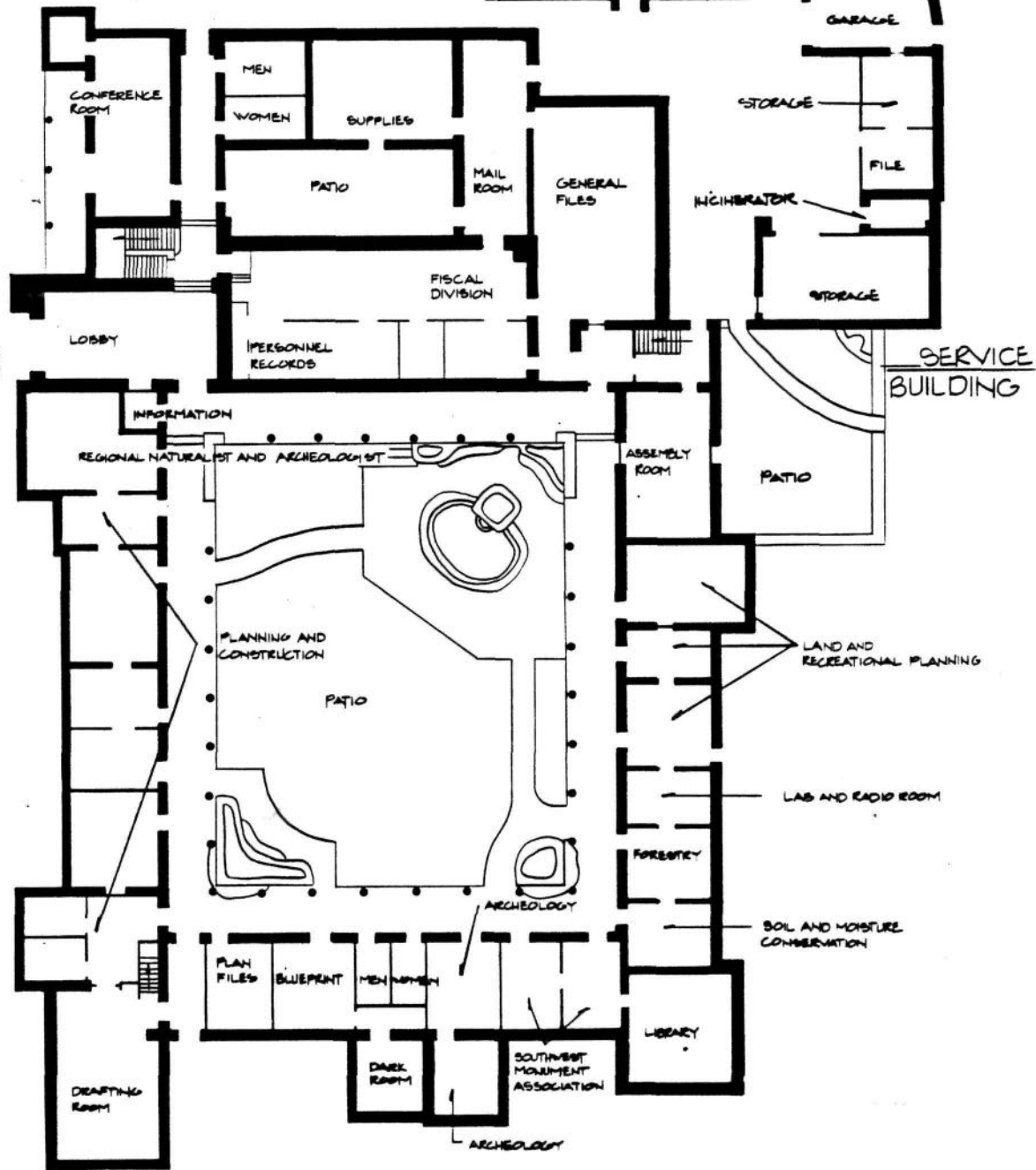
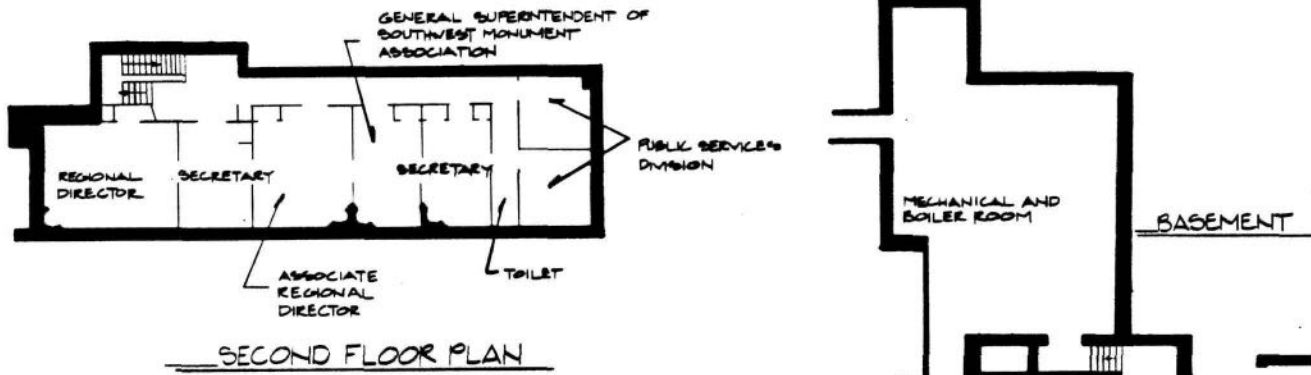

Figure 55.

Appendix A

Floor plans showing the use of each space when the building was designed in 1938.



EVOLUTION OF SPACES  
 1950

Figure 56.

Floor plans showing the use of each space during the 1950's.

## APPENDIX B

Plat and Property Acquisition

In 1928 Ernest and Arthur Knabel and the De Vargas Development Company donated 8.04 acres of land to Santa Fe's Laboratory of Anthropology. In 1937 the Laboratory of Anthropology donated the land to the National Park Service for the sole use of their headquarters building. The tract boundaries were located and plotted by Park Service engineers. The Hutchinson Abstract Company of Santa Fe brought the abstract up to date for \$400.00. The initial cost of construction materials and final closing costs on the land totaled \$3,986.43. The building was completed on June 30, 1939 for a total cost of \$81,645.42.

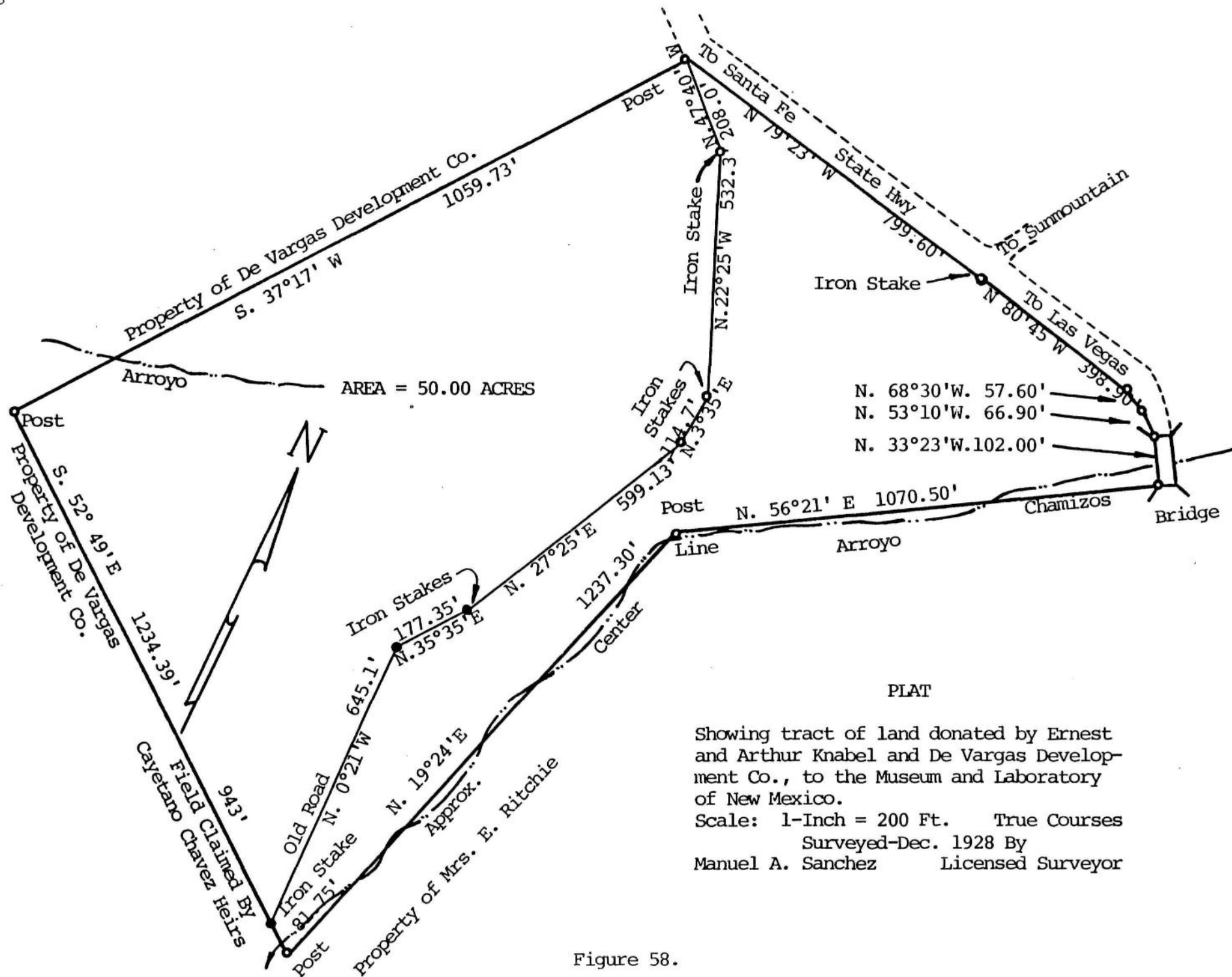

Figure 58.

## APPENDIX C

Fire Alarm System

In 1983 an extensive fire alarm system was added to the building. New alarm types included: ionization smoke detectors; Rate-of-Rise heat detectors; photo-electric smoke detector; alarm bells; manual Halon release; Halon bottle and solenoid; and a Halon pre-discharge chime. Also added were three 1-hour fire doors. All new detectors were located in the most inconspicuous places as possible. All wiring installations and other intrusions were carefully incorporated into the historic fabric so as not to alter the building's appearance or structure.

The following equipment requirement list was located in the Federal Archives Center in Denver which justifies the purchase of three fire hoses.

## Justification

- 2 -

The purchase of 3 fire hose racks, with hose and nozzles for the Regional Office Headquarters Building of the National Park Service, was accomplished by this Job.

No CCC man-days were used. Another Government Agency installed them.

Funds for this job were available for this period from allotment releases from Job 138 and from completed jobs..

ESTIMATE OF COST

1. Bill of Materials: unit and total prices, differentiate between emergency funds and contributions by park authority or sponsor.
2. Skilled Labor: number of hours contemplated, hourly rate and total cost for each type of labor, except CCC.
3. Equipment: rental only -- type, hourly rental, total cost, include operator when necessary.

(1) BILL OF MATERIALS:

3	#R-522 Hose Racks, pin type, with wall bracket suspension to carry 2 50-foot lengths of linen hose. Complete unit @ \$4.80/each, less 20%	\$ 11.52
6	#R-512 Linen Hose, 50-foot lengths, 1½", mildew proof for indoor use, fitted with cast brass couplings with National Standard fire threads. 300 feet 1½" hose with couplings @ \$0.27/foot, less 10%	72.00
3	#1406 Akron High Pressure Nozzle, 1½", 5/8" bore, shut-off type, with National Standard threads throughout. Complete. @ \$16.00/each, less 20%	<u>38.40</u>
	TOTAL -	\$121.92
	Contingency:	<u>7.00</u>
	JOB TOTAL -	\$128.92



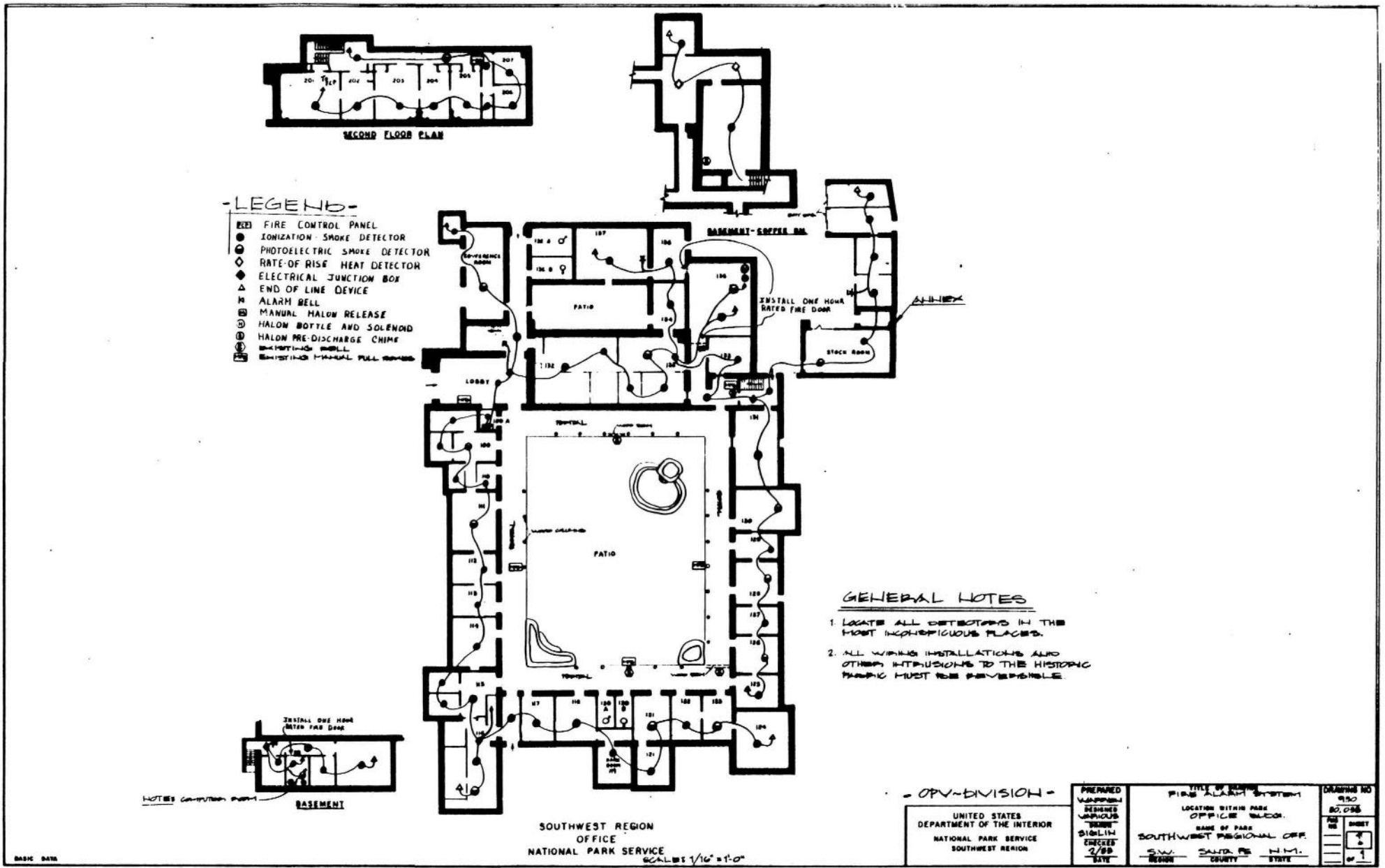

Figure 59.

Floor plan showing the current fire alarm system. Many alarm devices were installed throughtout the building.

Research Methodology

Research has included review of documents, microfilm and drawings in the collections of the National Park Service and other independent sources. Following are listed the most significant sources:

- The major portion of information came from the analysis of original architectural drawings and drawings on microfilm, located in both the west basement of the Southwest Regional Office and in the Graphics Division at the Denver Service Center.
- New Mexico State Archives: Research included Governor's papers and material on the Civilian Conservation Corps.
- New Mexico State Library: Extensive research was done in the microfilm collections of the Santa Fe New Mexican, 1937-1939; the Albuquerque Journal, 1937-1939; and the Albuquerque Tribune, 1937-1939.
- Zimmerman Library at the University of New Mexico: Research was done on the Civilian Conservation Corps in New Mexico.
- An oral interview with Frank Martinez was conducted on May 13, 1984. Mr Martinez has been employed as a maintenance worker with GSA for 27 years and has provided much valuable information.
- Historic photographs were obtained from the Harpers Ferry Photo Library in Springfield, Virginia. Thomas DuRand, Librarian.
- Photographs were also obtained from Mark Sawyer at the Western Archeological Conservation Center in Tucson, Arizona.

## APPENDIX E

Hardware

## Hardware Finishes

The Regional building has a wide variety of door, window and patio gate hardware. The majority of the doors in the building have hardware with a black finish. It is not known exactly what black finish process was used on the hardware in the Regional building, however, it is assumed that since the original "bower-barff" process was developed in the 1930s, it was the one used. This process required that the cast iron be heated to a temperature of over 1000 degrees, baking out a hard scale on the iron, and then dipped into an oil. Because of the manufacturing processes involved, the "bower-barff" process costs as much as brass and bronze (Brownell 1956).

Several years later other processes known as "parkerizing" and "bonderizing" were developed which generally replaced the "bower-barff" process. Both of these new rust-resisting processes, which use a phosphate coating, would stand up well if the base metal was properly prepared. Proper preparation was achieved by sandblasting the metal to give greater adhesion for the coatings. After the coating was applied the hardware was then lacquered. Other black finishes commonly used were dead-black electroplating, dead-black paint, lacquering and japanning (Ibid.).<sup>18</sup>

## Ball Bearing Hinges

A number of doors in the building are mortised into both the door and its frame by ball bearing butt hinges. There are two types of ball bearing hinges. One type has visible ball-bearing washers which were fastened to the knuckle, while the other has invisible ball bearings (the ball bearings are wholly concealed). The hinges used in the Regional Building are visible four-ball bearing butts with ball tips. Ball bearing hinges operate easily and quietly because the bearing metal is oil-impregnated and highly resistant to wear (Ibid.).

### Olive Knuckle Hinges

Olive knuckle hinges are used solely on the north entrance doors of the Regional building. Historically, they were available in two weights--regular and extra heavy--and in both ferrous and non-ferrous metal. Ferrous metal hinges were furnished in prime coat or plated finishes to match other hardware and were available in different widths. Olive knuckle hinges were more costly than regular butt hinges but were attractive in appearance and less conspicuous on a door. The hinges came either template or non-template and with either ball bearing or bronze washers.

### Door Latches and Locks

The doors in the Regional building use two types of latches and locks. One type, a "residence tabular entrance door set," is seen on many of the doors leading to the outside. This door set latches by knobs on both sides of the door and has a deadbolt which is opened with a key from outside and by hand inside. The lock sets have elongated escutcheons (a protective plate around a keyhole and door knob) with legs for bolting through the door.

The most common lock-set seen in the building is the "office door lock-set." This type latches by knobs on both sides of the door. When the outside knob is locked by stops in the face, a key must be used from the outside to open the door. Auxillary deadlocks latch the bolt but do not prevent operation by key or knobs. Many of the door sets have mortise and auxillary latches.

### Windows and Screens

The double-hung windows, window screens and screen doors seen in the building have hardware that was inexpensive to buy and simple to operate. The double-hung windows are opened by lifting up on a bar-sash lift and are locked by Crescent type sash fasteners. The window screens and screen doors have simple butt hinges and are opened by pulling on bar-drawer pulls. In the 1967 remodeling, all hardware removed for window or door repair or replacement was reused or exactly duplicated.

### Patio Gate Hardware

A unique lock, latch, and hinge, seen on the conference room patio gate, were designed by John Kell, Associate Landscape Architect, and made in Santa Fe.

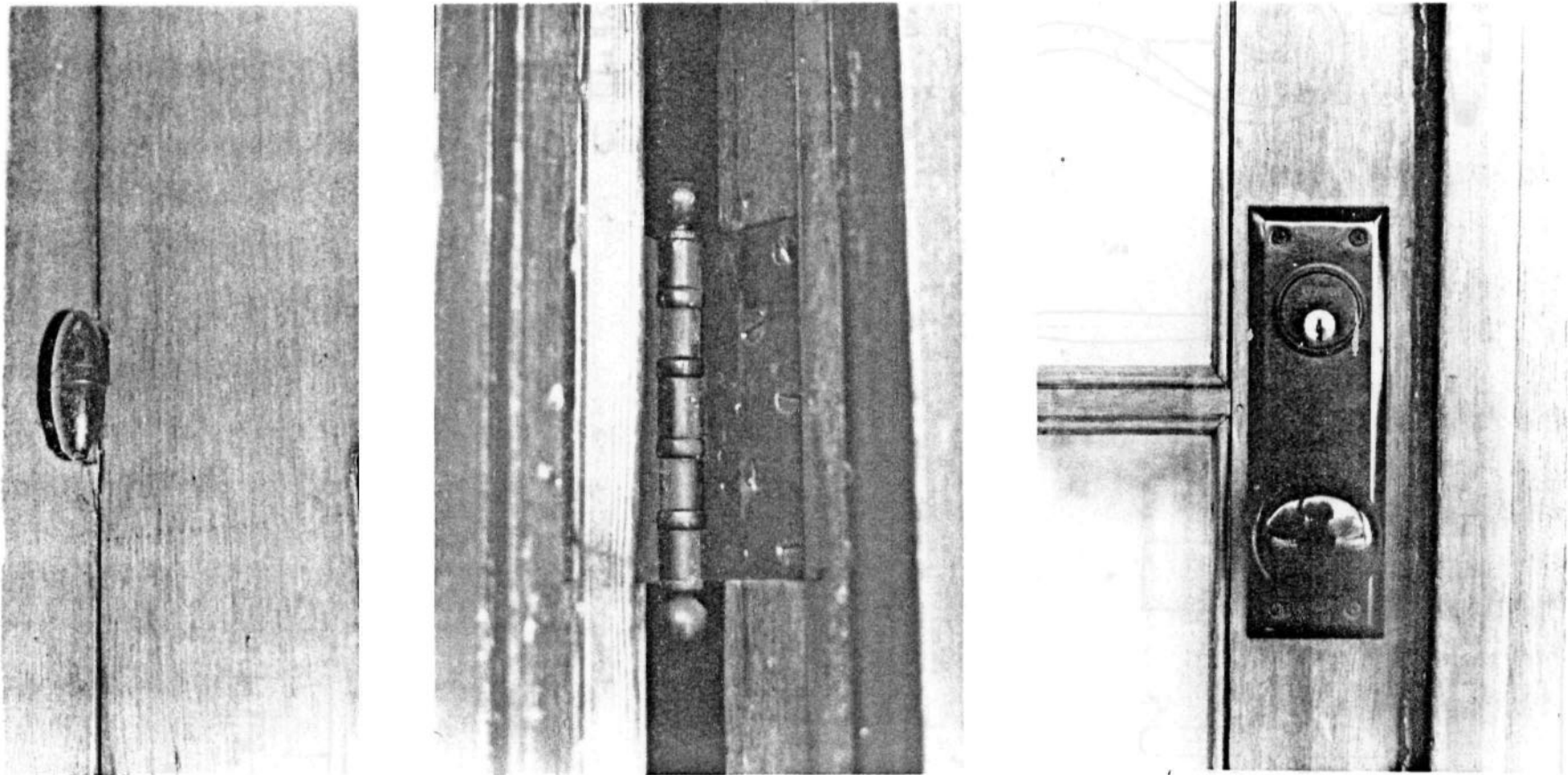

Figure 60.

Examples of original hardware. From left to right: A ball bearing of the knuckle hinge seen on the north entrance doors, a typical four-ball bearing door hinge and a residence tabular entrance door set.



## APPENDIX F

Specifications

The following outlines the specifications for the proposed Regional Office headquarters building.

OUTLINE OF SPECIFICATIONS

These plans comprise the first unit of the proposed Regional Office headquarters building. General plans only are included in this set. Mechanical plans covering detailed plumbing and electrical layouts are being prepared for field use as well as to be attached to all General sets for file and record purposes. Additional working details and full size details of mill-work, etc. will be prepared by the Regional Office for field use. Forming details and bending diagrams for all reinforced concrete work will be prepared for the field.

Heating plans have been prepared but materials are not included in following cost breakdown. Heating plans will be submitted separately.

All labor will be furnished by local CCC camp SP-1 N.M. in conjunction with Skilled workmen of the trades listed in material list. All supervision will be by local camp and Regional Office technical staffs.

Materials will be purchased in regular procedure by the respective State Park and Regional Office procurement branches. All materials to comply with their respective Government specifications and be installed in the best possible workmanship.

Roofing to be 4 ply 30 lb. felt over celotex and sheathing paper with asphalt and gravel surface coat comparable to Barrets 20 year Bonded roof.

All plumbing and electrical work to be installed in accordance with the National Park Service Recommended Building Code, revised edition 1935.

The building will be built entirely of adobe, except interior partitions as noted on plans. Exterior walls to be stuccoed with Bituadobe plaster, applied direct to walls. Interior plaster to be lime putty, 3 coats over metal lath. Interior plaster to be left plain, medium rough sand finish.

Floors to be cement finish concrete slab except flagstone as noted on plans. Cement base 4" high will be used throughout. Ceilings to be exposed Vigas with random width shiplap exposed directly above, except foyer and Regional Director's office which will be split savinas.

All vigas, ceiling boards, millwork with the exception of white pine sash and doors will be left unfinished to weather a natural color.



## BIBLIOGRAPHY

- Brownell, Adon H.  
1956 "Hardware Age, Builders' Hardware Handbook." Philadelphia: Chilton Company.
- Frei, Mary  
1983 "Former CCC Worker Recalls Northern New Mexico Efforts." Albuquerque Journal, October 22, 1983.
- Goodall, Harrison and Renee Friedman  
1980 "Log Structures. Preservation and Problem Solving." Nashville: The American Association for State and Local History.
- Maier, Herbert  
1939 "Old Spanish Style Seen in New Building." Santa Fe New Mexican, July 1, 1939.
- Martinez, Frank  
1984 Interview by Steven Burke, May 13, 1984.
- McGiffin, Robert F. Jr.  
1942 "Furniture Care and Conservation." Nashville: The American Association for State and Local History.
- New Mexico State Planning Office  
1973 "The Historic Preservation Plan for New Mexico" Vol. 2. Santa Fe.
- Santa Fe New Mexican  
1937 "Park Service Move Complete." October 9.  
1939 "Early Spanish Architecture is Featured." July 1.  
1939 "Park Service Moves into Beautiful New Building Here Today." July 1.  
1939 "Ten-Year Old Plum Tree Moves to Site." May 11.  
1939 "Tolson Heads Region Three of Park Service." May 11.

Tolson, Hillory A.

1939 "Santa Fe Considered Ideal Site for Park Service Headquarters."  
July 1.

U.S. Department of Interior, National Park Service

"Region III Headquarter's Welcome Letter for Visitors." Date unknown.

Volney, Westley

1985 Interview by Steven M. Burke, January 24, 1985.

Walker, Carl

1985 Interview by Steven M. Burke, January 24, 1985.

Wirth, Conrad L.

1980 "Parks, Politics, and the People." Norman: University of Oklahoma  
Press, p. 120.

