



LANCASTER *SURVIVOR*[®]

WATER PUMPS

INSTALLATION, OPERATION AND SERVICE MANUAL

SURVIVOR 4" SUBMERSIBLE PUMPS

POWERED BY

HYDRO-FORCE[®] 4" SUBMERSIBLE MOTORS

TWO AND THREE WIRE

SINGLE PHASE

1/2 THROUGH 1 1/2 H.P.

60Hz

MODEL NUMBER BREAKDOWN EXAMPLE

2-2LST5007-2

Catalog Section

2 = 2 Wire

3 = 3 Wire

L = Lancaster Hydro-Force[®] Motor

P = Plastic Discharge Head
Plastic Motor Support

S = Stainless Steel Discharge Head
Stainless Steel Motor Support

SP = Stainless Steel Discharge Head
Plastic Motor Support

2 = 230 Volt, Single Phase

Number of Stages

50 = 0.50 HP

75 = 0.75 HP

100 = 1.0 HP

150 = 1.5 HP

J = 5 GPM

L = 7 GPM

T = 10 GPM

U = 15 GPM

W = 22 GPM

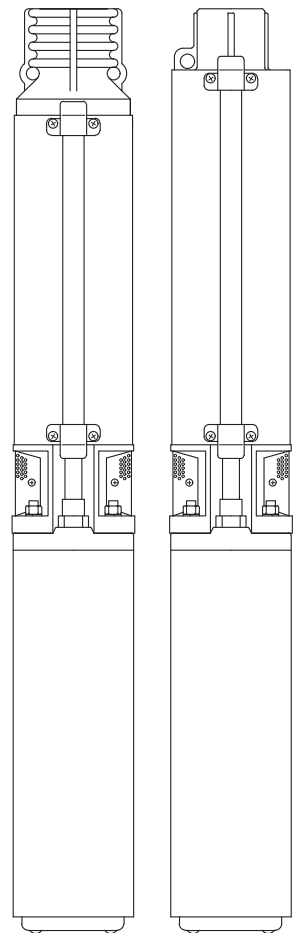

Congratulations on purchasing your new **Lancaster Survivor Submersible Pump**. This unit is designed to give you many years of trouble free service when installed in accordance with the following instructions. For servicing and future inspection purposes, please file this booklet with your important documents.

In the event that you need assistance for servicing your Survivor Submersible Pump, please first contact the professional contractor who installed the system.

CAREFULLY READ THE LITERATURE PROVIDED BEFORE INSTALLATION.

LANCASTER PUMP recommends an experienced water-well serviceman to install new water systems or replace an existing submersible water-well pump or pump motor. This manual should be retained for future reference.

INSPECT THE NEW PUMP: Occasionally, products are damaged during shipment. If the product is damaged, contact the transportation company or your dealer. Save the products packing materials until claim is settled. The package includes pump, motor and motor leads, fully assembled. **DO NOT** lift the submersible pump by its attached electrical motor leads. All SURVIVOR® pumps include a built-in check valve. Three-wire (plus a GROUND) single phase pumps must use a control box properly matched to the pumps motor. Two-wire (plus a GROUND) pumps **DO NOT** require a control box. Make sure that your available power supply line voltage and frequency corresponds to that of your motor.

INSTALLATION RECORD. Record the following information for future reference:	
Date of installation _____	Well Inside Diameter (in.): _____
*Pump Model No. _____	Depth of Well (ft.): _____
*Pump Serial No. _____	Depth to water (ft.): _____
*Motor Model No. _____	Depth to pump (ft.): _____
*Motor Serial No. _____	Well recovery rate (GPM): _____
*Motor: _____ H.P. _____ Volts _____ Ph _____ Amps (SFA)	Between well cap & house: _____ ft. horizontal offset
Control Box (3 Wire, 1Phase only): Model No. _____	_____ ft. elevation
Control Box (3 Wire, 1Phase only): _____ H.P. _____ Volts	Drop pipe size: _____
Power Supply _____ Volts _____ Ph _____ Hz	Wire size (pump to control box): _____
Pressure Switch (PSI) Cut-in _____ Cut-out _____	Wire size (control box to power source): _____
* This information is found on the pump or motor	

TABLE OF CONTENTS

SAFETY INSTRUCTIONS 3

PRE-INSTALLATION PREPARATION 4

INSTALLATION 5-10

SPLICING THE POWER CABLE 5

BEFORE LOWERING PUMP INTO WELL..... 6

LOWERING PUMP INTO WELL..... 6

ELECTRICAL CONNECTIONS 7

INITIAL START-UP 8

CONNECTING TO PRE-CHARGED TANK 8

CONTROLLING WEAK WELLS 8

INSTALLATION DIAGRAM 9

INSTALLATION OTHER THAN A WELL 10

SUBMERSIBLE MOTOR COOLING 10

TROUBLESHOOTING11

REMOVAL FROM WELL FOR SERVICE OR REPLACEMENT 12

SAFETY INSTRUCTIONS

THIS MANUAL CONTAINS IMPORTANT INSTRUCTIONS THAT SHOULD BE FOLLOWED DURING INSTALLATION, OPERATION, AND SERVICE OF THE PRODUCT. SAVE THIS MANUAL FOR FUTURE REFERENCE.



This is a **SAFETY ALERT SYMBOL**. When you see this symbol on the pump or in the manual, look for one of the following signal words and be alert to the potential for personal injury or property damage.



Warns of hazards that **WILL** cause serious personal injury, death or major property damage if ignored.



Warns of hazards that **CAN** cause serious personal injury, death or major property damage if ignored.



Warns of hazards that **CAN** cause minor or moderate personal injury or property damage if ignored.

The label **NOTICE** indicates special instructions which are important but not related to person injury.

TO AVOID SERIOUS OR FATAL PERSONAL INJURY OR MAJOR PROPERTY DAMAGE, READ AND FOLLOW ALL SAFETY INSTRUCTIONS IN MANUAL AND ON PUMP.

WARNING **Hazardous voltage.** Can shock, burn or cause death. Do not install this pump in any pond, river, or other open body of water that could be used for swimming or recreation. Do not swim, wade or play in a body of water in which a submersible pump has been installed.

- Installation must meet United States National Electrical Code, Canadian Electrical Code, and local codes (as applicable) for all wiring.
- Disconnect electrical power supply before installing or servicing pump.
- Make sure line voltage and frequency of power supply match motor name plate voltage and frequency.
- Do not lift, carry or hang pump by the electrical cables.
- All splices must be waterproof.

WARNING **Hazardous pressure.** Under certain conditions, submersible pumps can develop extremely high pressure. Install a pressure relief valve capable of passing entire pump flow at 75 PSI when using an air over water pressure tank. Install a pressure relief valve capable of passing entire pump flow at 100 PSI when using a pre-charged pressure tank.

CAUTION **Risk of freezing.** Do not allow pump, pressure tank, piping or any other system components containing water to freeze. Freezing may damage system, leading to injury or flooding.

ELECTRICAL GROUNDING INFORMATION

WARNING **Hazardous voltage.** Can shock, burn or kill. Reduced risk of electric shock during operation of this pump requires the provision of acceptable grounding:

- 1) When the means of connection to the supply-connection box is other than grounded metal conduit, ground the pump back to the service by connecting a copper conductor, at least the size of the circuit conductors supplying the pump, to the grounding screw provided within the wiring compartment.
- 2) This pump is provided with a means for grounding. To reduce the risk of electrical shock from contact with adjacent metal parts, bond supply box to the pump-motor-grounding means and to all metal parts accessible at the well head, including metal discharge pipes, metal well casing, and similar parts, by means of:
 - i) An equipment-grounding conductor at least the size of the well-cable conductors, or the equivalent, that runs down the well with the well cable and
 - ii) A clamp, a weld, or both when required, secured to the equipment-grounding lead, the equipment-grounding terminal, or the grounding conductor on the pump housing.

The equipment-grounding lead, when one is provided, is the conductor that has an outer surface of insulation that is green with or without one or more yellow stripes.

NOTICE: Install pump according to all plumbing, pump and well code requirements.

NOTICE: This pump has been evaluated for use with WATER ONLY.

NOTICE: Test well water for purity before using well. Call your local health department for testing procedure.

NOTICE: During installation, keep well covered as much as possible to prevent leaves and foreign matter from falling into well. Foreign objects in well can contaminate the water and cause mechanical damage to the pump.

NOTICE: Pipe joint compound can cause cracking in plastics. Use only PTFE pipe thread sealing tape with sealing joints in plastic pipe or when connecting pipe to thermoplastic pumps.

PRE-INSTALLATION PREPARATION

CAUTION: DO NOT run pump dry. Pump and motor can be damaged if run dry.
The pump has been factory tested with the same motor assembled to it.
For safe testing, wait until pump is grounded, wired and completely submerged.

THE WELL:

The well casing must be 4" inside diameter or larger to accept the pump. Pump performance is based on pumping clear, cold water with no entrained air. The well driller should properly develop the well, i.e. pump out all fine sand, dirt and foreign matter, before pump is installed. The location of the well should provide for easy removal and replacement of the pump. The water tank and electrical controls can, of course, be located some distance from the well. Determine the maximum depth of the well, using the well drillers record if available, taking into account the static water level and the drawdown level at the proposed pumping rate. **Make sure you have the right pump.** Pump selection and setting depth should be based on this data. Ensure that the pump setting depth will always be at least 3 feet below the maximum drawdown level of the well. Set the pump at least five feet from the bottom of the well to keep above sediment and debris. Do not set the pump below the well casing perforations or well screen unless provisions are made to ensure the minimum requirement for water flow over the motor for cooling purposes. Refer to Submersible Motor Cooling section.

ELECTRICAL CABLE:

Determine the depth of the pump in the well in order to purchase electrical cable of sufficient gauge and length to reach from pump motor to electrical power supply. Properly sized copper wire from service to motor will avoid over-heating wire and excessive voltage drop at the motor. Consult dealer or electrician or refer to LANCASTER HYDRO-FORCE® Technical Bulletin for more information regarding cable selection.

DROP PIPE:

Drop pipe is used to suspend the pump in the well. Determine the depth of the pump in the well in order to purchase pipe of sufficient length to reach from pump discharge to water tank.

Galvanized pipe is recommended for suspending all submersible pumps into the well, although it is used mainly for high capacity, high head pumps. Requires a power lift and pipe holder for installation and removal. Since galvanized pipe is rigid, problems due to starting torque are not present.

Rigid PVC plastic pipe is installed in lengths as is galvanized pipe. Easier to handle due to light weight. Safety rope is recommended to prevent loss of pump if pipe should break. Often used on high capacity, medium to low head pumps.

Flexible polyethylene pipe is most commonly used on domestic size pumps. **Plastic pipe manufacturers recommendations of depth and pressure must be observed. Pressure rating must be greater than maximum pressure of pump.** Pipe should be double clamped with all stainless steel clamps. Safety rope to prevent loss of pump recommended. A torque arrestor is recommended just above pump to prevent chafing of electrical cable when pump and pipe twist during the starting and stopping cycle.

CHECK VALVES:

Check valves are used to hold pressure in the system when the pump stops. They also prevent backspin, waterhammer and upthrust; any of these conditions can lead to operating problems in the system and either a shortened service life or immediate failure of the pump or motor. The pump has a built-in check valve. This built-in check valve is designed so that it may be removed (not recommended). If the built-in check valve is removed as a remedy for air-lock (see Controlling Weak Wells section), it is recommended to install a positive sealing in-line check valve in the discharge line within 25 feet of the pump and below the maximum drawdown level of the well. Additional in-line check valves should be installed per manufacturers recommendations. Always use positive sealing in-line check valves for submersible pump installations. DO NOT use swing type check valves because they have a slower reaction time and can cause water hammer.

Submersible pump setting in well	Suggested Check Valve Installation
200 feet or less	Pump built-in check valve and one in-line check valve on surface of well upstream from the pressure switch and tank (see installation diagram)
200 feet to 800 feet	Pump built-in check valve and additional in-line check valves installed at maximum 200 ft. intervals of drop pipe and one at the surface of well upstream from the pressure switch and tank (see installation diagram)

LOCATION OF WATER TANK & ELECTRICAL CONTROLS:

Always install the pressure tank and electrical controls in a clean, dry basement or utility room to avoid dampness and temperature extremes. Install a pressure relief valve in the system close to the pressure tank. The relief valve should be piped to a suitable drain and be capable of discharging the flow rate of the pump at the rated working pressure of the pressure tank. Install a pressure switch between the check valve and the pressure tank. Locate the pressure switch as close as possible (within 4 feet) of the pressure tank to prevent switch chatter. Three wire control boxes should be mounted where protection from direct sunlight or high temperatures is provided, preventing a reduction in capacitor life and unnecessary tripping of the overload protector.

LIGHTNING ARRESTORS:

Lightning arrestors are recommended for every installation. All HYDRO-FORCE® 4" single phase motors have built-in lightning arrestors, as indicated on the motor frame label. An additional external lightning arrestor may be used, installed as close to the wellhead as possible. Install the arrestor per manufacture's instructions. A lightning arrestor provides protection against induced voltage surges on secondary power lines; **it is not effective against direct hits. The arrestor must be grounded, metal to metal, all the way to the water strata, for it to be effective. Grounding the arrestor to a driven ground rod provides little or no protection for the motor.** Many present-day electrical codes require a ground wire from the pump to the supply grounding terminal. When this ground wire is used, the above-ground arrestor can be grounded acceptably by connecting to it.

INSTALLATION

SPLICING THE POWER CABLE:

Follow the instruction enclosed in the cable splicing kit you purchase.

If splicing each motor lead to the drop cable is carefully done, the splice will be as efficient as any other portion of the cable and be completely waterproof. We recommend the **taped splice** method or **heat shrink splice** method.

Before using either method:

1. Examine the motor leads and drop cable carefully for damage.
2. Cut the motor leads in a staggered manner to minimize the mechanical bulk at any one point, i.e. stagger so that the 2nd lead is 2" longer than the 1st lead and the 3rd lead is 2" longer than the 2nd lead.
3. Cut off the drop cable ends. Be sure to match colors and lengths of wire in the drop cable to colors and lengths of motor leads.

Taped splice:

- A. Trim insulation back 1/2" from cable ends and motor lead ends.
- B. Insert motor lead ends and cable ends into butt connector (see Figure 1). Match wire colors between drop cable and motor leads.
- C. Using crimping pliers (Figure 4), indent butt connector lugs (see Figure 2).
- D. Form a piece of electrical insulation putty tightly around each butt connector. The putty should overlap on the insulation of the wire.
- E. Using UL® - approved water-submersion-grade vinyl electrical tape, wrap each joint tightly; cover wire for about 1 1/2" on each side of joint. Make four passes with the tape. In other words, when finished you should have four layers of tape tightly wrapped around the wire. Press edges of tape firmly down against the wire (see Figure 5).

NOTICE: Since the tightly wound tape is the only means of keeping water out of the splice, the efficiency of the splice will depend on the care used in wrapping the tape.

NOTICE: For wire sizes larger than #8, use a soldered joint rather than putty (see Figure 3).

Heat-shrink splice:

- A. Remove 3/8" insulation from ends of motor leads and drop cable ends.
- B. Put plastic heat shrink tubing over motor leads.
- C. Match wire colors and lengths in drop cable to wire colors and lengths of motor leads.
- D. Insert cable and motor lead ends into butt connector and crimp (See Figures 1 and 2). **BE SURE** to match wire colors between drop cable and motor leads. Pull leads to check connections.
- E. Center tubing over butt connector and apply heat evenly with a torch (a match or lighter will not supply enough heat).

NOTICE: Keep torch moving. Too much concentrated heat may damage tubing (see Figure 6).

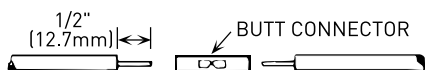

Figure 1

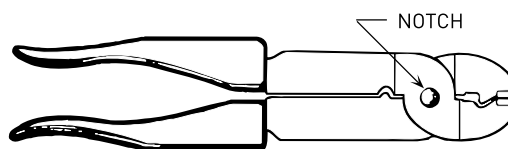

Figure 4



Figure 2

AND FORM ELECTRICAL INSULATION PUTTY TIGHTLY AROUND CONNECTOR, OVERLAPPING WIRE INSULATION



Figure 5

COMPLETED SPLICE



Figure 3

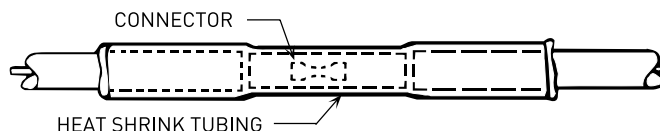

Figure 6

BEFORE LOWERING PUMP INTO WELL:

1. Smooth out any rough spots or edges on the top lip of the well casing with a hammer or metal file to prevent damage to the pump or power cables, when lowering into well.
2. Make sure check valves are installed as described in Pre-Installation Preparation section.
3. Install a torque arrestor per manufacturer's instructions, on the PVC or flexible polyethylene discharge pipe just above the pump to prevent chafing of cable when pump and pipe twist during starting and stopping.
4. **NOTICE:** All SURVIVOR® pumps are assembled with right hand threads on the discharge head and motor adaptor. The internal pipe threads in the discharge head are 1¼" standard NPT. Hold the pump's discharge head with a wrench when connecting the drop pipe. Be sure not to loosen or over-tighten the pump's discharge head in the stainless steel pump casing. Do not hold the pump's stainless steel casing with a wrench during installation.

Installing the Pump with Flexible Polyethylene Pipe

- Using a brass or stainless steel 1¼" NPT x 1" barbed male adapter (if 1" pipe is being installed), wrap the 1¼" NPT male thread with PTFE sealing tape.
 - Install the adapter into the pump discharge opening while holding the discharge head with a pipe wrench to prevent the head from turning in the pump casing. **NOTICE: DO NOT OVERTIGHTEN MALE ADAPTER INTO PLASTIC HEAD;** hand tighten plus ¾ to 1 full turn with a wrench maximum.
 - Slip two 1" **all stainless steel** hose clamps over the end of the pipe and temporarily slide them away from pipe end.
 - Heat the polyethylene pipe end with a torch to soften the pipe. **NOTICE:** Keep torch moving. Too much concentrated heat may damage pipe.
 - Press the polyethylene pipe over the adapter's barbed end.
 - Tighten hose clamps securely around the pipe over the adapter's barbed end.
5. To prevent losing pump down the well, connect a safety rope strong enough to support pump and drop pipe (minimum ¼" twisted polypropylene rope) to eyelet on pump discharge or male adaptor. Tie off other end of safety rope securely to well seal, well cap, pitless adaptor or bring it through the well seal and tie off to a sturdy anchor point, e.g. a post that is concreted into the ground.
 6. **NOTICE:** Plastic pipe tends to stretch under load and must be taken into account when securing the power cable to the drop pipe. Tie or tape (nylon zip ties or waterproof vinyl electrical tape) power leads to plastic pipe within 6" of the pump discharge, leaving 4"-5" of slack in leads at this point, to allow for stretching of pipe when installed in well. Avoid leaving too much slack in leads in order to prevent leads from rubbing on the well casing.
 7. Tie or tape (nylon zip ties or waterproof vinyl electrical tape) power cables to the pipe every 10', straight up from the bottom to top. **DO NOT** spiral cable around the pipe. **DO NOT** allow any excess cable between bands; cable must be as flat against pipe as possible.

LOWERING PUMP INTO WELL:

1. **NOTICE:** NEVER allow pump cable to support weight of pump and pipe. Take care when beginning to lower pump down the well casing. **DO NOT** let the pump, cables or pipe rub against the well casing. **DO NOT** let the cable insulation drag or scrape over the top lip of the casing.
2. Lower the pump into the well slowly without forcing. Use a pipe vise or foot collar clamp to hold galvanized or PVC pipe while connecting the next length of pipe and taping the power cables. As you add sections of galvanized or PVC pipe, apply sealant only to the male threaded ends of each section and tighten to next section.
3. Install additional spring-loaded check valves as described in Pre-Installation Preparation section.
4. Lower pump at least 3' below the maximum drawdown of the water level, more if possible, and never closer than 5' from the bottom of the well.
5. When a well seal is used, pass the pipe and power cable through the openings in the well seal. Install a coupling, elbow or tee on the top end of the last vertical length of pipe and allow the fitting to rest on the outside of the well seal to support the pipe, power cables and pump. Well seals provide a tapped conduit hole for the submersible pump cable. Conduit must be used to protect cables and prevent water and foreign matter from leaking into well around cable. Well seals provide a tapped vent hole. The well seal must be vented. Install the well seal into the well casing by tightening down cap screws on the well seal. See installation diagram.
6. In installations where the pipe from the well seal to the water tank is subject to frost or freezing conditions, a pitless installation using a pitless adaptor and ventilated well seal cap with conduit connection is recommended. See installation diagram.
7. Use an ohmmeter to make insulation and continuity checks on the cable after the pump is installed. This locates any fault in the cable.

ELECTRICAL CONNECTIONS:

Employ a licensed electrician to do the wiring.

All wiring must be done in accordance with applicable national and local electrical codes.

NOTICE: Every installation **MUST** be grounded. There **MUST** be a reliable ground connection between the pump and the distribution panel. The motor lead incorporates a green grounding conductor. See Safety Instructions section and below for detailed electrical grounding information.

Refer to wiring and installation diagrams.

Power supply is wired directly from the main switch to a separate fused disconnect switch. Consult dealer or electrician or LANCASTER HYDRO-FORCE® Technical Bulletin for correct circuit breaker or fuse amp rating.

All single phase motors are automatically protected against overload damage by built-in thermal control element.

Use an ohmmeter to make continuity and insulation checks after the installation is complete.

NOTICE: For three (3) wire single phase pumps, connect the three (3) colored wires of the pump cable to the matching black, red and yellow terminals of the motor control box, i.e. always connect like colors.

For two (2) wire single phase pumps, connect pump cables directly to load terminals of the pressure switch (color matching is not necessary).

NOTICE: Refer to Pre-Installation Preparation section of this manual for information regarding **lightning arrestors**.

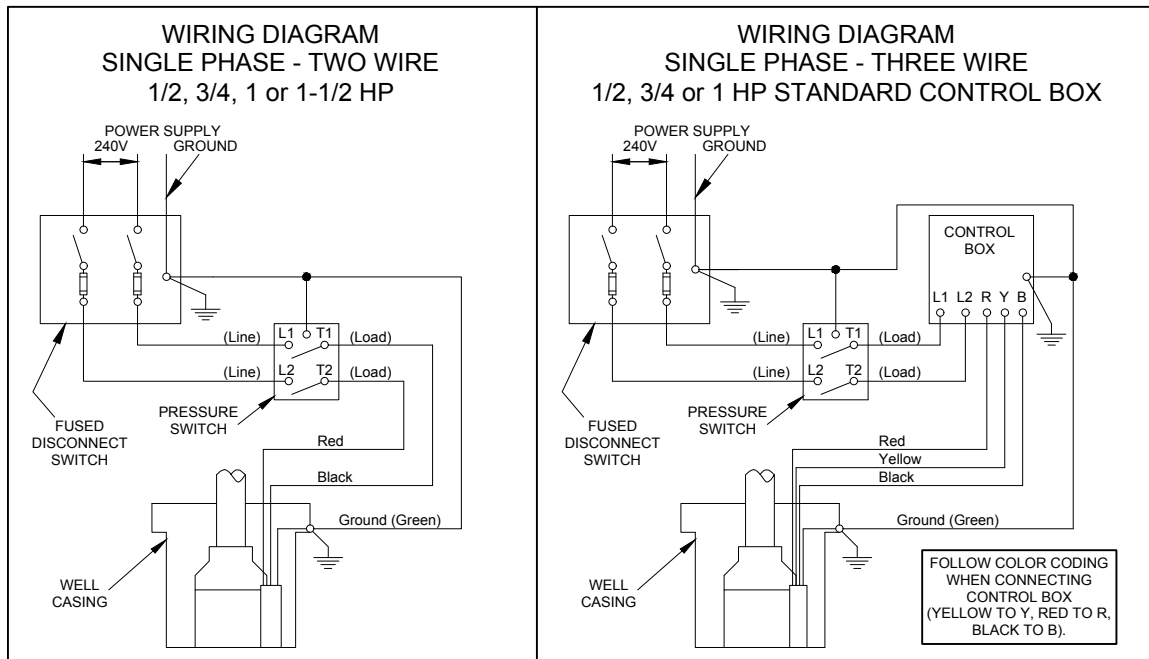

Typical SQUARE D
9013FSG Pumptrol®
Pressure Switch
Terminal Block Arrangement

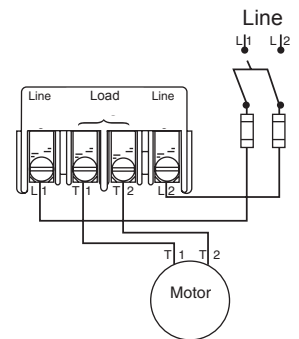

ELECTRICAL GROUNDING INFORMATION

⚠ WARNING Hazardous voltage. Can shock, burn or kill. Reduced risk of electric shock during operation of this pump requires the provision of acceptable grounding:

- 1) When the means of connection to the supply-connection box is other than grounded metal conduit, ground the pump back to the service by connecting a copper conductor, at least the size of the circuit conductors supplying the pump, to the grounding screw provided within the wiring compartment.
- 2) This pump is provided with a means for grounding. To reduce the risk of electrical shock from contact with adjacent metal parts, bond supply box to the pump-motor-grounding means and to all metal parts accessible at the well head, including metal discharge pipes, metal well casing, and similar parts, by means of:
 - i) An equipment-grounding conductor at least the size of the well-cable conductors, or the equivalent, that runs down the well with the well cable and
 - ii) A clamp, a weld, or both when required, secured to the equipment-grounding lead, the equipment-grounding terminal, or the grounding conductor on the pump housing.

The equipment-grounding lead, when one is provided, is the conductor that has an outer surface of insulation that is green with or without one or more yellow stripes.

INITIAL START-UP:

CHECK THE PUMP AND WELL PERFORMANCE BEFORE MAKING FINAL CONNECTION TO PRESSURE TANK.

1. With all electrical connections complete and pump now lowered to desired depth, install a gate valve in the discharge pipe near the well for preliminary test run. Arrange discharge line so that the water can be run to waste. This will prevent dirty water from entering the pressure tank and piping system. Adjust the gate valve one-third of the way open.
NOTICE: Never operate the pump with the discharge valve completely closed. The pump can destroy itself if run with discharge shut off ("deadheaded").
2. Turn on power to start the pump.
3. Slowly open valve in small increments to increase flow as water clears.
NOTICE: Never start the pump with the discharge valve completely open if the pump will operate at high flow-low head (well with a high static water level) or if pump is placed in an artesian well. This could cause upthrust damage to the pump's impellers-shaft assembly.
4. If the water is not clear, let the pump run until water clears. If water does not clear in 30 minutes, stop pump and take necessary steps to correct the condition. After the water has appeared clear, check for sand by discharging into a clean bucket. Never stop pump if sand flows with water, as sand will lock up the pump impellers and the pump cannot be started again. If sand does not eventually clear up, the pump should be pulled and well cleaned by a well driller.
5. Close valve gradually until maximum required system flow rate is obtained. Ensure that the pump does not lower the water in well to a point where the pump loses prime.
6. Remove gate valve for permanent installation to tank.

CONNECTING TO PRE-CHARGED PRESSURE TANK:

See installation diagram.

1. **NOTICE:** Check air pre-charge in tank with a tire gauge before starting pump. Adjust pre-charge to 2 PSI below pump cut-in setting. For example, a pre-charge tank used with a 30-50 PSI pressure switch should be pre-charged with air to 28 PSI. Adjust pre-charge by either adding or bleeding air through the valve located atop the tank.
2. The pressure tank should be as close as possible to the pressure switch to prevent switch chatter. Connect all piping as shown in diagram.
3. Start pump. Pressure in tank will build up to cut-off pressure of pressure switch setting. The system should now operate automatically. NOTE: If your pressure switch is equipped with a loss of pressure cut-off switch (with a lever) it will be necessary for you to move and hold the lever in the start position until the pump builds sufficient pressure to remain on without holding lever in the start position. The pump will run until system pressure builds up to the cut-out setting of the switch. The system will operate automatically between the cut-in & cut-out pressure setting on the switch.

CONTROLLING WEAK WELLS:

A weak (low-yielding) well exists when the output rate from the pump is greater than the recovery rate (yield) of the well. It can lower the water level in the well to the pump suction screen, causing a mixture of air and water to enter the pump. Pumping may stop because the pump cannot generate pressure with insufficient water. If this occurs, the column of water already in the drop pipe holds the pumps check valve closed and an airlock may develop inside the pump. An airlock inside the pump creates **inadequate** lubrication and cooling for the pump stages and motor. Damage can result if the power is not cut off quickly. Use one or more of the following methods to correct and/or protect this installation:

1. If possible, install additional length of drop pipe to place pump lower in the well.
2. Install a SymCom PumpSaver Plus® electronic motor load sensing device.
3. Remove the pump "built-in" or external mounted check valve, and install a spring-loaded check valve in the discharge line within 25 feet of the pump and below the maximum drawdown level of the well. Moving the check valve this distance above the pump provides a column of drop pipe for air to escape to as the pump attempts to prime after well recovery.
4. Install a flow control valve in the discharge pipe before (upstream from) the pressure switch and tank. This restricts the output rate from the pump without affecting the rate that water can be drawn from the pressure tank. Throttle the valve to a rate that the well will yield without drawing down. A tank with larger draw-down capacity (gallons) or multiple tanks in parallel should be considered for more water storage.
5. Install a pump with a lower flow rating to avoid over pumping the well. Have the dealer size pump to the well yield.
6. A low-pressure cut-off switch may be considered, but only for shallow wells. Low-pressure cut-off switches detect loss of pressure at the surface (at the pressure tank), but an air lock could have already formed inside the pump deep down the well.

INSTALLATION DIAGRAM

PITLESS ADAPTOR INSTALLATION FOR UNDERGROUND CONNECTION OF DROP PIPE TO DISCHARGE PIPE PROVIDING A WATERTIGHT SANITARY SEAL.

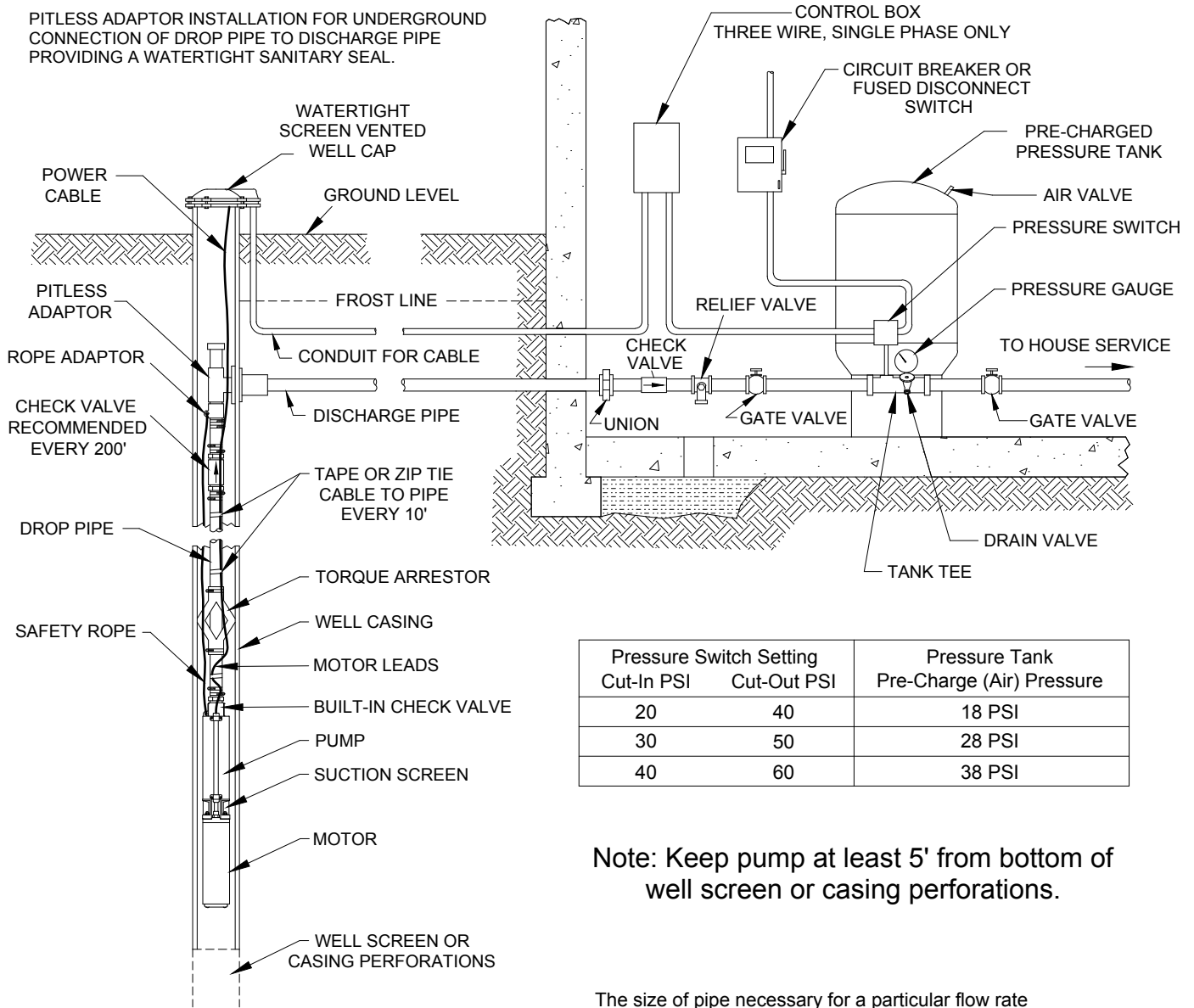

Pressure Switch Setting Cut-In PSI	Pressure Switch Setting Cut-Out PSI	Pressure Tank Pre-Charge (Air) Pressure
20	40	18 PSI
30	50	28 PSI
40	60	38 PSI

Note: Keep pump at least 5' from bottom of well screen or casing perforations.

The size of pipe necessary for a particular flow rate is determined by:

- 1) Friction head loss considered acceptable.
- 2) Maintaining a minimum flow velocity of approximately 2 feet per second to avoid clogged pipes.
- 3) Limiting flow velocity to approximately 5 feet per second (use caution if velocity exceeds 5 fps; do not exceed 8 fps) to avoid water hammer.

WELL SEAL INSTALLATION USED IN WARM CLIMATES WHERE THE WELL IS TERMINATED ABOVE GROUND.

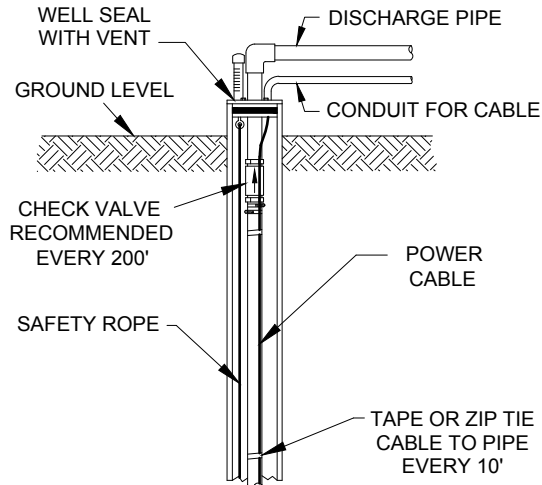

SUGGESTED PIPE SIZE (PUMP TO TANK)	
FLOW RATE (GPM)	NOMINAL PIPE SIZE (INCHES)
5	1
7	1
*10	1
*10	1-1/4
15	1-1/4
22	1-1/4

* For 10 GPM, 1 inch pipe size acceptable to 300 feet depth to water. If depth to water exceeds 300 feet, suggest 1-1/4 inch pipe size.

INSTALLATION OTHER THAN A WELL:

A submersible pump is usually isolated at the bottom of a well, where electrical leakage from its motor and cable present no hazard to life. This natural protection is lost when you install it in a lake, pond, stream or fountain since there is no way to prevent people and livestock from entering or touching the surrounding water.

⚠ WARNING Risk of electric shock. Can shock, burn or kill. Do not install this pump in any pond, river, or other open body of water that could be used for swimming or recreation. Do not swim, wade or play in a body of water in which a submersible pump has been installed.

Grounding as instructed previously in this manual is a minimum requirement, and a ground fault circuit interrupter (GFCI) should be considered although if the system is properly grounded and bonded, a GFCI should not be necessary for a direct wired (no electrical receptacle or outlet) installation. In fact, a GFCI may nuisance trip on submersible pump installations due to the long length of submersible cable. Capacitance increases with cable length causing minor leakage current to flow through the ground conductor to ground. If there are no explicit national or local regulations, ask the local electric utility company for guidance.

The pump is designed to be mounted in the vertical, motor “shaft-up” position. If the pump must be mounted “shaft-horizontal”, support the pump from the shore or bottom, with the shaft up 15° from the horizontal, for proper motor bearing lubrication, and also reduce the number of starts to less than 10 per 24 hr. period to maintain normal motor thrust bearing life expectancy. Use an external positive sealing spring-loaded check valve on the pump discharge connection (the pump’s built-in non-spring-loaded check valve is only useful for vertical installations). Shield the pump from direct physical contact. Protect pump intake from blockage by leaves and weeds, but remember that the pump needs adequate flow over the motor for proper cooling. A flow inducer sleeve should be used in any open body of water. Refer to Submersible Motor Cooling Section. Furthermore, always protect the entire underwater installation from water currents, ice, boats, anchors, debris, etc..

SUBMERSIBLE MOTOR COOLING:

Electric motors produce heat that must be dissipated, otherwise the heat will build up in the motor and cause motor failure. Submersible motors use the water being pumped for cooling, i.e. the submersible motor requires a minimum flow of water past it to the pump intake to ensure proper cooling. Even though the motor is submerged in water, several types of installations are possible in which water could enter the pump intake from above the motor instead of past the motor, e.g. an open body of water, a pump set below the well screen or casing perforations, a top-feeding (cascading) rock well or a well diameter that is too large. For optimum service life, these applications require a **flow inducer sleeve** placed around the motor. The sleeve should have an inside diameter of 4” to 6”, and be comprised of corrosion resistant metal and thin wall PVC pipe. The sleeve will ensure proper flow of water past the motor for cooling. The flow inducer sleeve is closed above the pump intake and extends to the bottom of the motor or lower. Several flow inducer sleeves are available on the market such as SUB-KOOL by Lakos and FlowSleeve by FlowSleeve Manufacturing. LANCASTER HYDRO-FORCE® 4” submersible motors are designed to operate up to maximum service factor horsepower in water up to 95°F (35°C) with a minimum flow of 0.25 ft/s (0.08 m/s) required for proper cooling (see table).

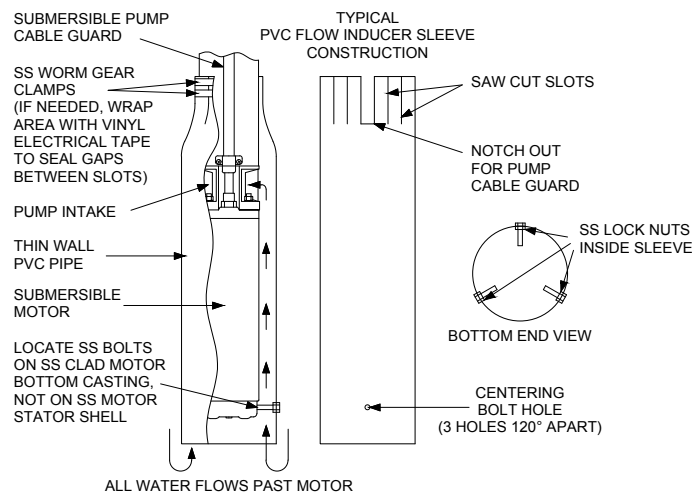

Required Cooling Flow	
Minimum GPM required past motor in water up to 95°F (35°C)	
Casing/Sleeve ID inches	4”motor 0.25 ft/s GPM
4	1.2
5	7.0
6	13
7	20
8	30

Example: A 4” pump that delivers 7 GPM will be installed in a 6” well. From the table, 13 GPM would be required to maintain proper cooling therefore adding a 5” or smaller flow sleeve provides the proper cooling.

NOTICE: If the water temperature is 68°F (20°C) or less, some water movement but no minimum cooling flow is required as long as the pump is installed vertically and is contingent on no adverse operating conditions, e.g. poor power, high start/stop frequency, incrustated deposits on the motor surface, etc.. Adverse operating conditions are difficult to predict therefore the minimum cooling flow should be provided when possible - regardless of the water temperature.

TROUBLESHOOTING

PROBLEM	POSSIBLE CAUSE/SOLUTION
PUMP DOES NOT START:	<ol style="list-style-type: none"> 1. No power to start motor. Check voltage at line side of fuse box. Contact power company if no power is reaching fuse box. 2. Fuses blown or circuit breakers tripped. Check fuses for recommended size and check for loose, dirty or corroded connections in fuse receptacle. Check for tripped breakers. Replace with proper fuses or reset circuit breaker. 3. Defective pressure switch. Check voltage at contact points. Improper contact at switch points can cause voltage less than line voltage. Replace pressure switch or clean points. 4. Control box malfunction (3-Wire, single phase only). Call dealer or electrician for repair or replacement. 5. Defective wiring. Check for loose or corroded connection or incorrect wiring. See wiring diagram. 6. Defective cable or motor. Splices bad. Call dealer or electrician. 7. Electronic motor load sensing device (if installed) has pump turned off (drawdown protection). 8. Reset low pressure cutoff switch (if installed).
PUMP STARTS BUT OVERLOAD PROTECTOR TRIPS OR FUSES BLOW:	<ol style="list-style-type: none"> 1. Wrong size fuse or circuit breaker. Call dealer or electrician for recommended size. 2. Wire size too small. Call dealer or electrician. 3. Control box malfunction (3-wire, single phase only). Call dealer or electrician for repair or replacement. 4. Incorrect voltage. Check voltage at line terminals. Contact power company if supply line voltage is low. Motor can withstand periodic fluctuations in voltage of $\pm 10\%$ for 2-wire design and $+6\% -10\%$ for 3-wire design but is not able to run indefinitely on a low voltage. For 230V single phase motors on 208VAC single phase supply, a buck-boost transformer is required to boost voltage by 10%. 5. Defective wiring. Check for loose or corroded connections or incorrect wiring. See wiring diagram. 6. Defective cable or motor. Splices bad. Call dealer or electrician. 7. High ambient (atmospheric) temperature. Check temperature of control box. The box must not be hot to touch. Direct sunlight or other heat source can raise temperature of box causing protectors to trip. Shade box, provide ventilation or move box away from heat source. 8. Pump or motor stuck or binding. Pump may be sand bound. Amp readings will be 3 to 6 times higher until the overload trips. If necessary, remove pump from well (make all possible above ground checks first). If pump is locked, replace it. Clean well of all sand before reinstalling pump.
PUMP STARTS TOO FREQUENTLY:	<ol style="list-style-type: none"> 1. Pre-charged tank water-logged (loss of air pressure). Adjust air pressure to 2 PSI less than cut-in pressure (when there is no water pressure on system). Check tank for leaks. Must be air and water tight. Replace if necessary. Is tank sized too small to meet system requirements? 2. Defective pressure switch or switch out of adjustment. Re-adjust or replace pressure switch. Pressure switch should be located as close to the tank as possible. 3. Check valves leaking. Damaged or defective check valve will stick open and leak back. Replace if defective. 4. Leak in system. Tank losing pressure through leaking plumbing fixtures. Check all above-ground piping for leaks. If none, pull pump and check all pipe connections and connection of pipe to pump.
PUMP RUNS CONTINUOUSLY:	<ol style="list-style-type: none"> 1. Pressure switch may have welded contacts. Switch may be out of adjustment. Clean contacts, replace switch or adjust setting. 2. Low water level in well. Pump may exceed well capacity. Pump may be air-locked. Refer to "Controlling Weak Wells" section of this manual. 3. Leak in system. Check system for leaks. Replace damaged pipe or repair leaks. 4. Worn pump. Symptoms of a worn pump are similar to those of drop pipe leak or low water level in well. Reduce pressure switch setting, if pump shuts off worn pump may be the fault.
PUMP DELIVERS LITTLE OR NO WATER:	<ol style="list-style-type: none"> 1. Pump not submerged in water. Low water level in well. Pump may be air-locked. Refer to "Controlling Weak Wells" section of this manual. 2. Check valve installed backwards. Reverse and re-install. 3. Check valve stuck closed. Replace if defective. 4. Pump intake screen blocked. Pump in mud. Pump impellers partially clogged or plugged. Pull pump and clean. Raise pump if necessary, i.e. reset pump depth. 5. Setting too deep for rating of pump. Call dealer, check pump rating table. 6. Piping might be split and leaking. 7. Low voltage. Wire size too small. Call dealer or electrician. 8. Worn pump.

REMOVAL FROM WELL FOR SERVICE OR REPLACEMENT

LANCASTER PUMP recommends an experienced water-well serviceman/pump installer to service or replace an existing submersible water-well pump or pump motor. This type of experienced contractor will have the knowledge to comply with all local codes and regulations and trained personnel with the proper equipment to make sure the job is done quickly and efficiently.

All relevant above-ground tests and procedures as described in the Troubleshooting section should be performed to help determine if the pump must be removed from the well for service or replacement.

⚠ WARNING **Risk of electric shock.** Turn off the circuit breaker or fuse supplying power to the submersible pump.

Knowing the depth of the well and the depth to the pump is necessary to determine if there is a large enough area to layout the pipe as the pump is being pulled out of the well.

Remove the well cap. Loosen the pitless adaptor by screwing a pulling tee clockwise into the female thread end of the pitless adaptor until fully engaged. The pulling tee is a removal tool made from 5 foot x 1 inch NPT steel pipe; 1 inch NPT for 1 inch pitless adaptors and 5 foot or longer depending on the depth of the pitless adaptor below the frost line in your area. Extend the tee pipe handles so they extend beyond the well casing outside diameter. Raise the pulling tee to lift the pitless adaptor and piping above the top of the well casing. **⚠ CAUTION** The combined weight of the pump, cable and water-filled pipe is very heavy, often more than 100 pounds for just a 100 foot pump depth and much heavier for deeper depths. Once the pitless adaptor becomes loose, all the weight of the pump, cable and water-filled pipe will be on what you are pulling on... **NEVER pull the pump and piping by the electrical cable.** It is likely the pipe will be very slippery due to iron or mineral deposits; non-slip gloves will be necessary. At least two people will be required, each physically able to continuously lift the pipe during removal. One additional person will be needed to guide the flexible polyethylene pipe away from the well as the other people are lifting it out. If the pump is installed with rigid PVC or galvanized pipe, a derrick and winch to lift pump by the pipe, and a pipe vise or foot collar to hold the pipe while unscrewing and removing each section is needed.